

YAMAHA

GENUINE

PARTS CATALOGUE

MOTORCYCLE

CYLINDER

Ref. No.	Part Number	Description	Qty	Remarks
1	(3R4-11111-00-00)	HEAD, CYLINDER 1	1	
2	1W3-11181-00-00	GASKET, CYLINDER HEAD 1	1	
3	(CMP-N2G00-00-00)	CHAMPION N2G 10PK	1	
4	90116-08321-00	BOLT, STUD	6	
5	90179-08491-00	NUT, FLANGE	6	
6	4V5-11311-00-00	CYLINDER 1	1	
7	3R4-11351-00-00	GASKET, CYLINDER	1	
8	90116-10313-00	BOLT, STUD	2	
9	90116-10314-00	BOLT, STUD	2	
10	95701-10500-00	NUT, FLANGE (95702-10500)	4	
11	99530-14016-00	PIN, DOWEL	2	
12	3R4-14619-01-00	HOOK, SPRING	1	
13	2N6-11127-00-00	ABSORBER 3	2	
14	4V5-11161-00-00	ABSORBER 1	2	
15	4V5-1131E-00-00	HOLDER 1	1	
16	97013-06012-00	BOLT	1	
17	92995-06100-00	WASHER, SPRING	1	
18	90201-063J2-00	WASHER, PLATE	1	

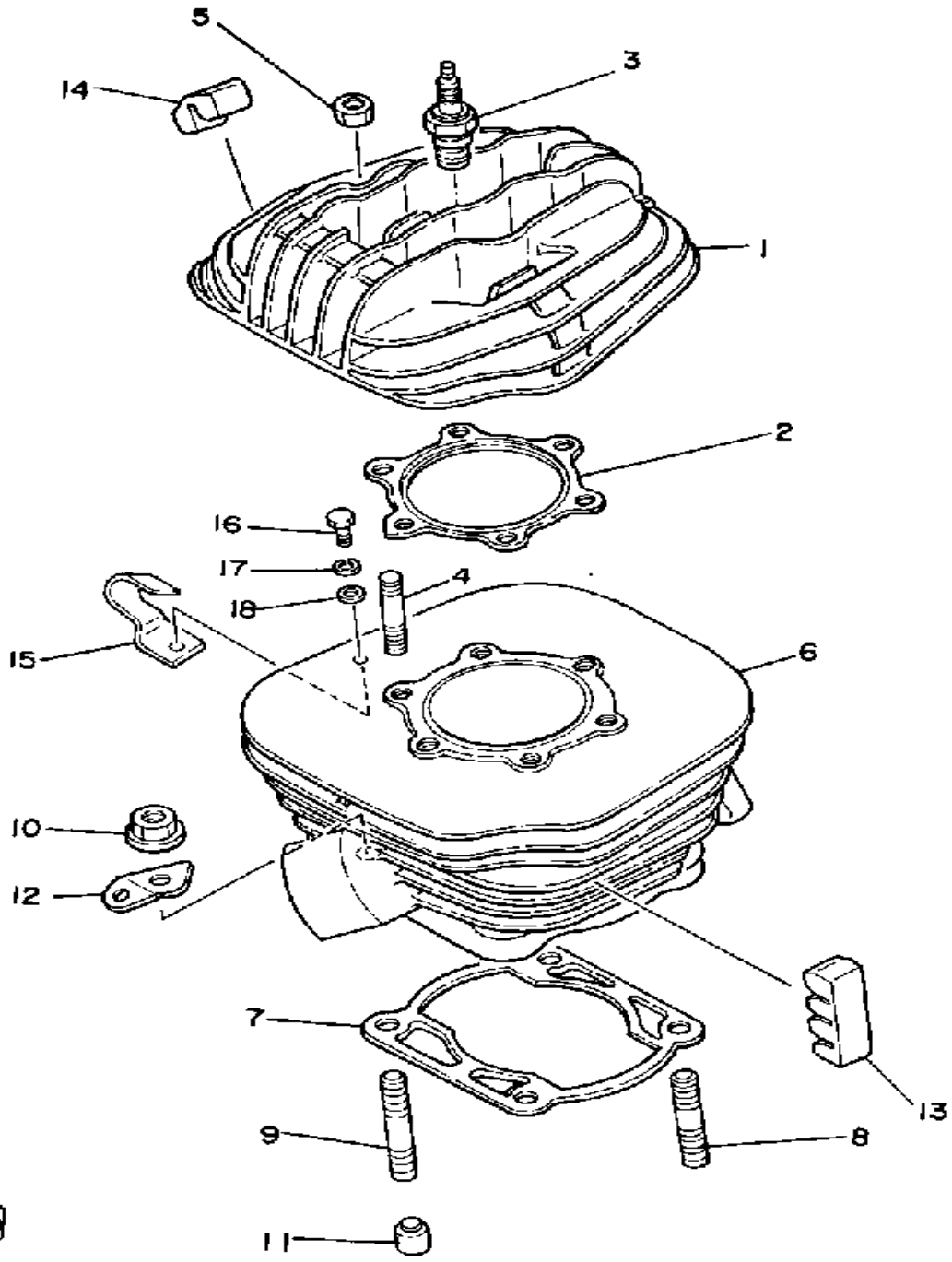

FWD

CRANKSHAFT - PISTON

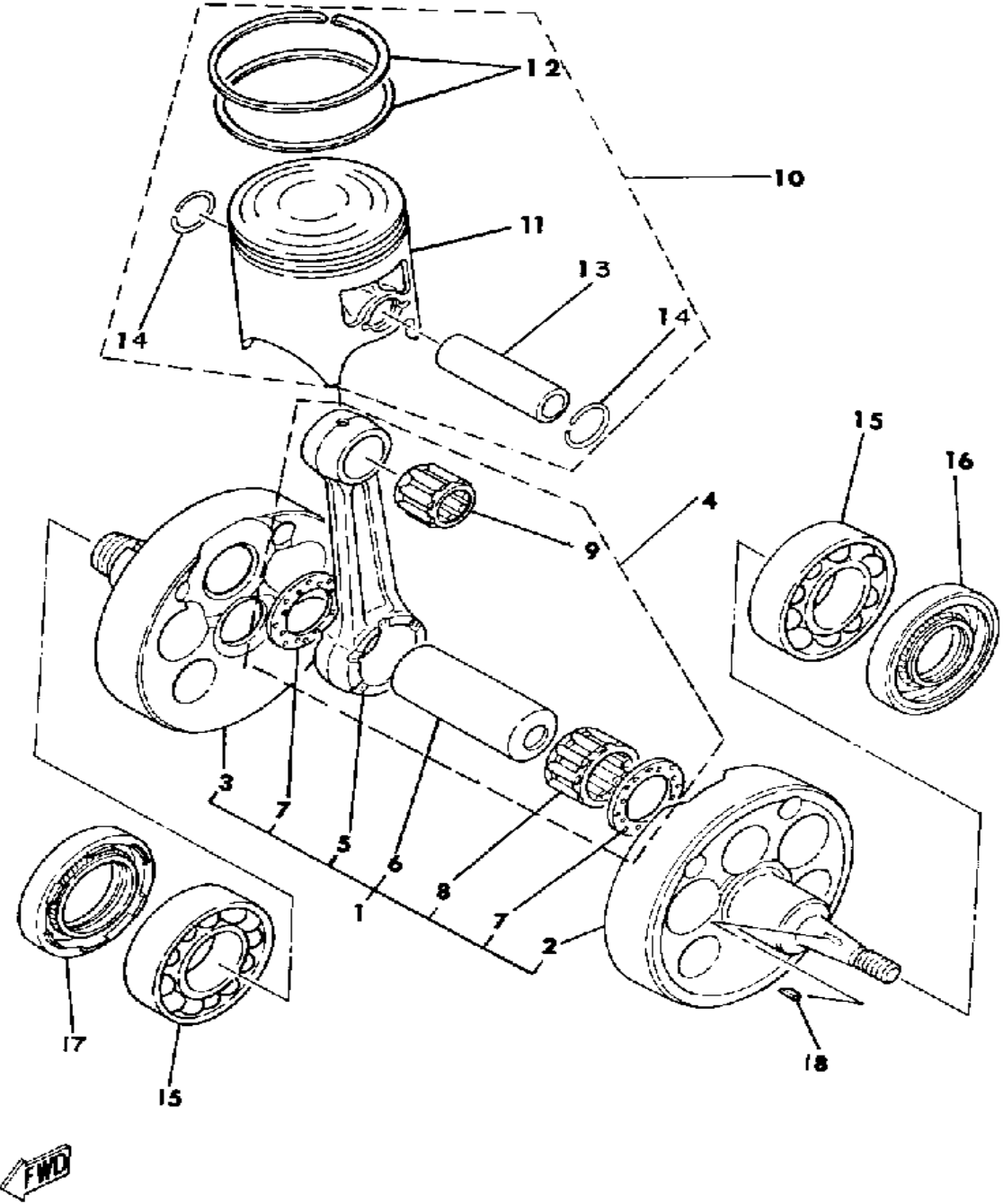

Ref. No.	Part Number	Description	Qty	Remarks
1	(4V5-11400-00-00)	CRANKSHAFT ASSEMBLY ...	1	
2	(4V5-11412-00-00)	CRANK 1	1	
3	3R4-11422-00-00	. CRANK 2	1	
4	5X5-11650-00-00	. CONNECTING ROD ASSEMBLY	1	ASSEMBLY
5	498-11651-00-00	.. ROD, CONNECTING	1	
6	2X4-11681-00-00	.. PIN, CRANK 1	1	
7	90209-25085-00	.. WASHER	2	
8	93310-425N4-00	.. BEARING, CYLINDER.# 0 ..	1	
9	93310-218A6-00	. BEARING	1	
10	4V5-11630-00-00	PISTON ASS'Y (STD)	1	ASSEMBLY
11	4V5-11631-00-95	PISTON STD (STD)	1	
12	1W5-11610-00-00	PISTON RINGSET STD (2X7-11610-00)	1	
13	214-11633-00-00	PIN, PISTON	1	
14	93450-19052-00	CIRCLIP	2	
15	93306-20627-00	BEARING	2	
16	93103-30150-00	OIL SEAL (38W)	1	
17	93103-40091-00	OIL SEAL, SW-TYPE	1	
18	(4V5-11630-10-00)	PISTON KIT 1ST	1	ALTERNATE PARTS
	(4V5-11630-30-00)	PISTON KIT 3RD	1	ALTERNATE PARTS
	1W5-11610-10-00	PISTON RINGSET 1ST (2X7-11610-10)	1	ALTERNATE PARTS
	1W5-11610-20-00	PISTON RINGSET 2ND (2X7-11610-20)	1	ALTERNATE PARTS
	1W5-11610-30-00	PISTON RINGSET 3RD (2X7-11610-30)	1	ALTERNATE PARTS
	1W5-11610-40-00	PISTON RINGSET 4TH (2X7-11610-40)	1	ALTERNATE PARTS
	4V5-11630-20-00	PISTON KIT 2ND (2ND O/S) ...	1	ALTERNATE PARTS
	4V5-11630-40-00	PISTON KIT 4TH (4TH O/S) ...	1	ALTERNATE PARTS

CONTINUED ON NEXT FRAME ►

CRANKSHAFT - PISTON

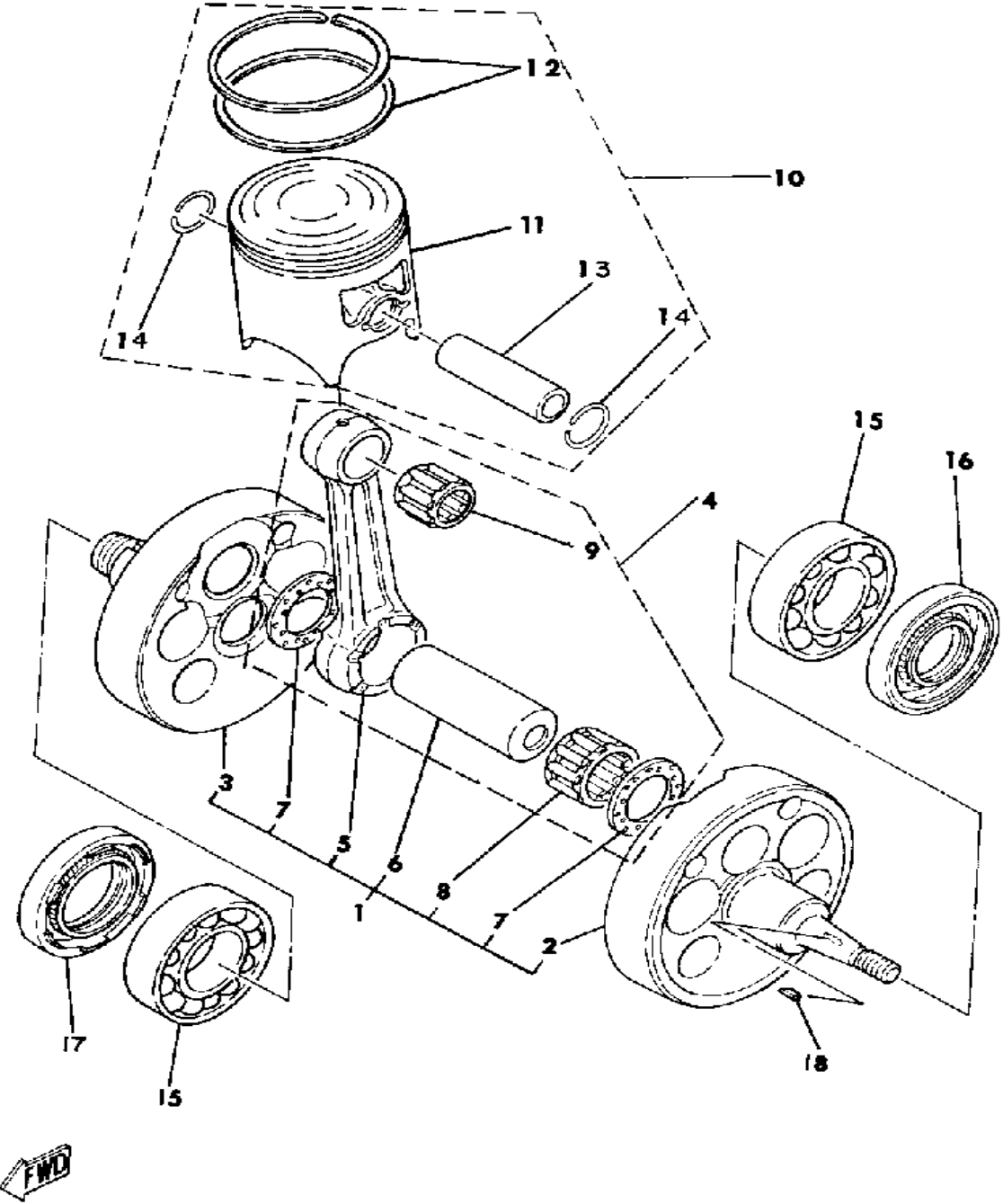

Ref. No.	Part Number	Description	Qty	Remarks
18	4V5-11635-00-00	PISTON 1 O/S 0.25 (1ST O/S 0.25MM)	1	ALTERNATE PARTS
	4V5-11636-00-00	PISTON 2 O/S 0.50 (2ND O/S 0.50MM)	1	ALTERNATE PARTS
	4V5-11637-00-00	PISTON 3 O/S 0.75 (3RD O/S 0.75MM)	1	ALTERNATE PARTS
	4V5-11638-00-00	PISTON 4 O/S 1.00 (4TH O/S 1.00MM)	1	ALTERNATE PARTS
	90280-03017-00	KEY, WOODRUFF	1	

C - D - I MAGNETO

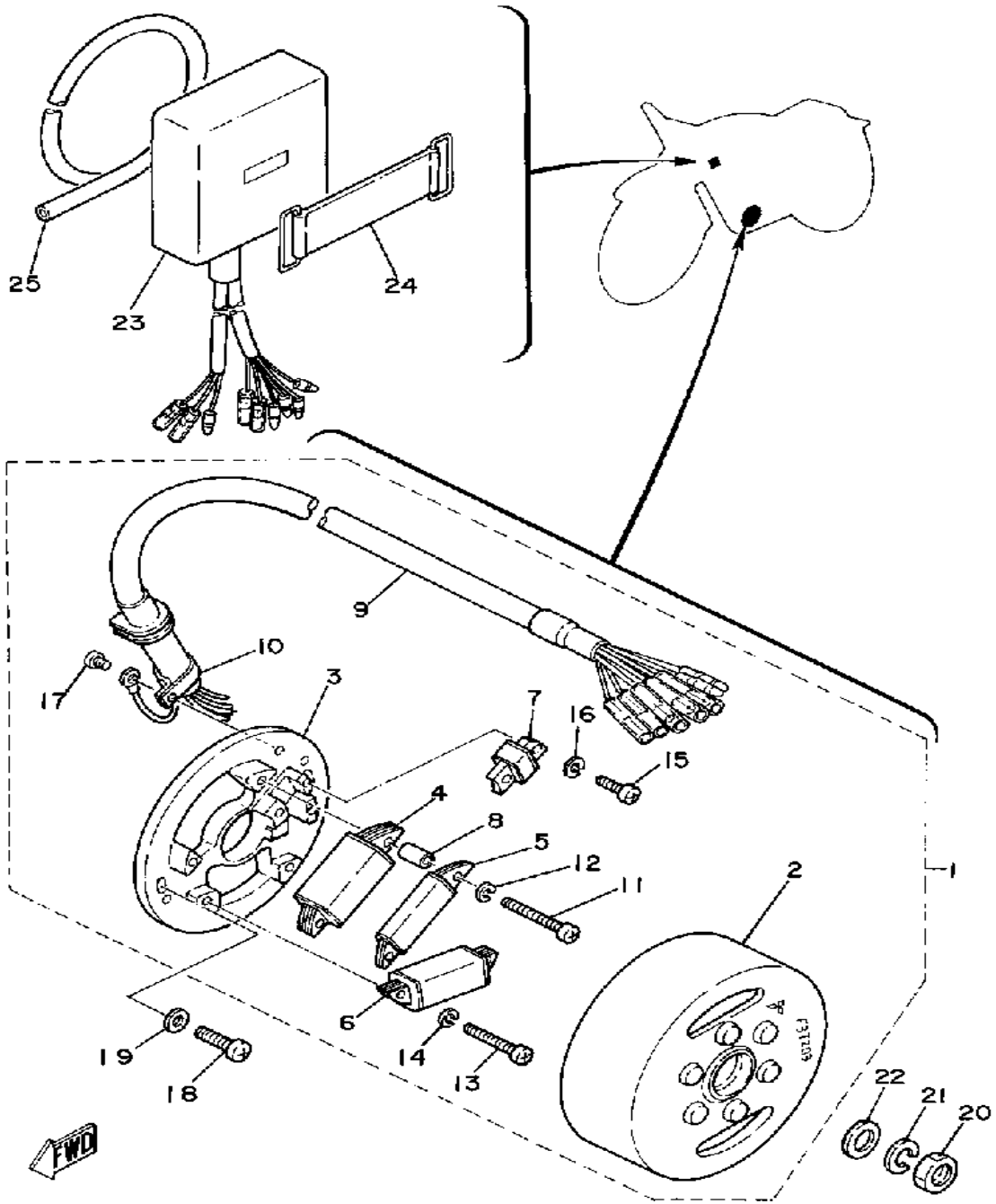

Ref. No.	Part Number	Description	Qty	Remarks
1	4V5-85500-20-00	CDI MAGNETO ASSEMBLY ...	1	
2	4V5-85550-20-00	. ROTOR ASSEMBLY	1	
3	(4V5-85509-20-00)	BASE, MAGNETO	1	
4	4V5-85511-20-00	. COIL SOURCE 1	1	
5	4V5-85512-20-00	. COIL SOURCE 2	1	
6	1W2-85513-20-00	. COIL, LIGHTING 1	1	
7	(4V5-85580-20-00)	COIL, PULSER	1	
8	1W2-85516-20-00	. SPACER	2	
9	5L4-85515-20-00	. LEAD WIRE ASSEMBLY	1	
10	104-81328-20-00	. CLAMP	1	
11	98501-04035-00	. SCREW, PAN HEAD	2	
12	92901-04100-00	. WASHER, SPRING	2	
13	98511-04030-00	. SCREW, PAN HEAD	2	
14	92901-04100-00	. WASHER, SPRING	2	
15	98503-04014-00	. SCREW, PAN HEAD	2	
16	92901-04100-00	. WASHER, SPRING	2	
17	97601-04106-00	. SCREW, PN/HD.W/WSHR ...	1	
18	98580-06020-00	SCREW	2	
19	92901-06600-00	WASHER	2	
20	90170-12347-00	NUT, HEXAGON	1	
21	92901-12100-00	WASHER, SPRING	1	
22	90201-12593-00	WASHER, PLATE	1	
23	4V5-85540-20-00	CDI UNIT ASSEMBLY	1	
24	116-82131-00-00	BAND, BATTERY	1	
25	(90445-10183-00)	HOSE	1	

INTAKE

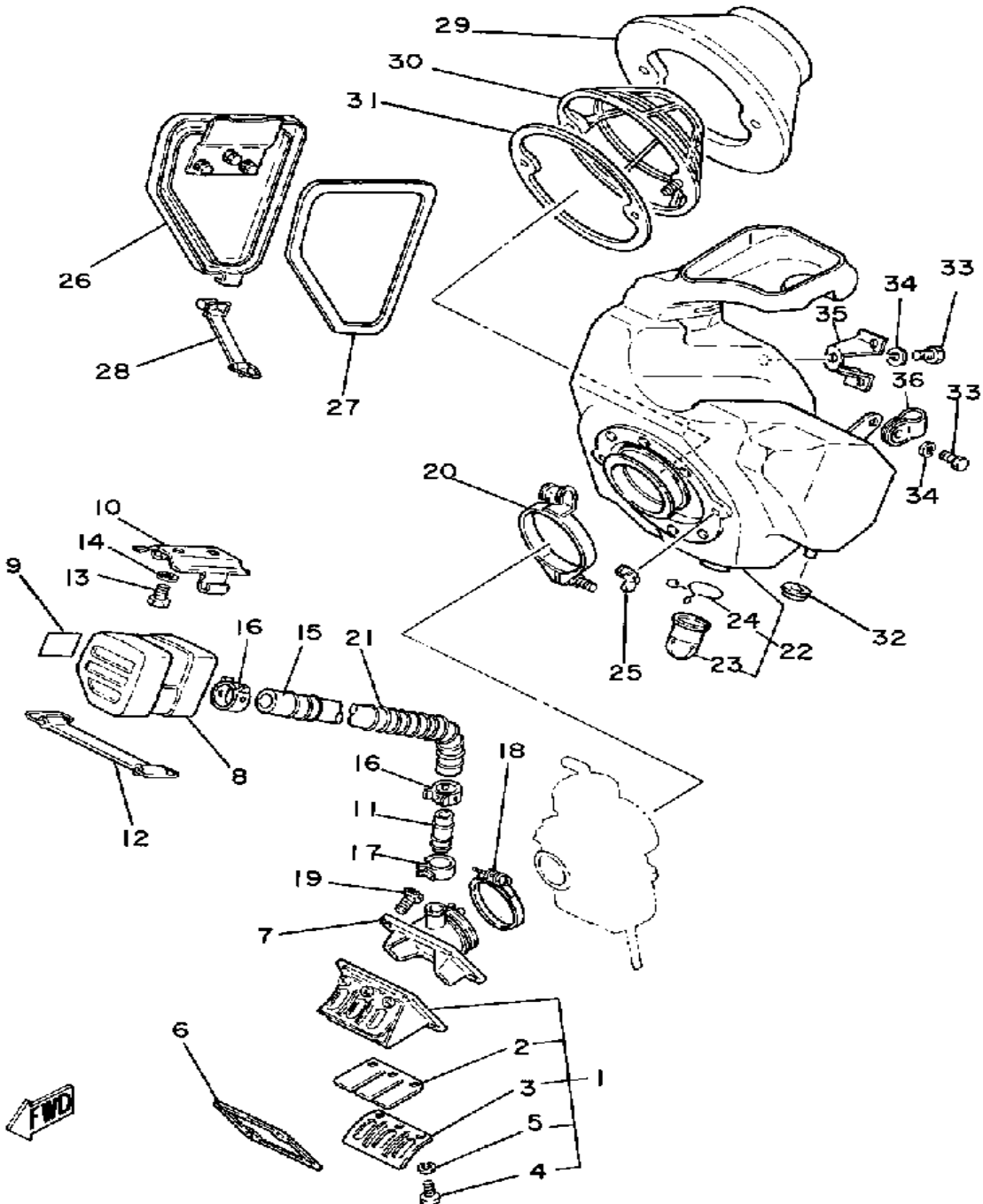

Ref. No.	Part Number	Description	Qty	Remarks
1	2X5-13610-00-00	REED VALVE ASSEMBLY	1	
2	2K7-13613-00-00	. REED, VALVE	2	
3	2X5-13616-00-00	. STOPPER, REED VALVE	2	
4	98580-03008-00	. SCREW, PAN HEAD	6	
5	92990-03100-00	. WASHER, SPRING (92901-03100)	6	
6	80L-13621-01-00	GASKET, VALVE SEAT	1	
7	4V3-13565-00-00	JOINT, CARBURETOR	1	
8	4V3-13581-00-00	CHAMBER, AIR	1	
9	4V3-1441K-00-00	EMBLEM	1	
10	4V3-14493-00-00	STAY 1	1	
11	4V3-13584-01-00	PIPE, MANIFOLD	1	
12	1E6-82131-00-00	BAND, BATTERY	1	
13	97011-06010-00	BOLT	2	
14	92995-06100-00	WASHER, SPRING	2	
15	90445-21562-00	HOSE	1	
16	90467-20050-00	CLIP, SCISSOR	2	
17	90468-08104-00	CLIP	1	
18	90460-51109-00	CLAMP, HOSE	1	
19	91316-06020-00	BOLT, SOCKET HEAD	4	
20	90460-68231-00	CLAMP, HOSE	1	
21	90501-14633-00	SPRING, COMPRESSION	1	
22	(4V5-W1441-00-00)	AIR CLEANER CASE	1	
23	1W4-14457-00-00	. SEAL	1	
24	90467-20030-00	. CLIP	1	
25	90175-06008-00	NUT, WING	2	
26	4V5-14412-00-00	CAP, CLEANER CASE 1	1	
27	5X5-14452-00-00	SEAL	1	
28	4V5-14455-00-00	BAND	1	

CONTINUED ON NEXT FRAME ►

INTAKE

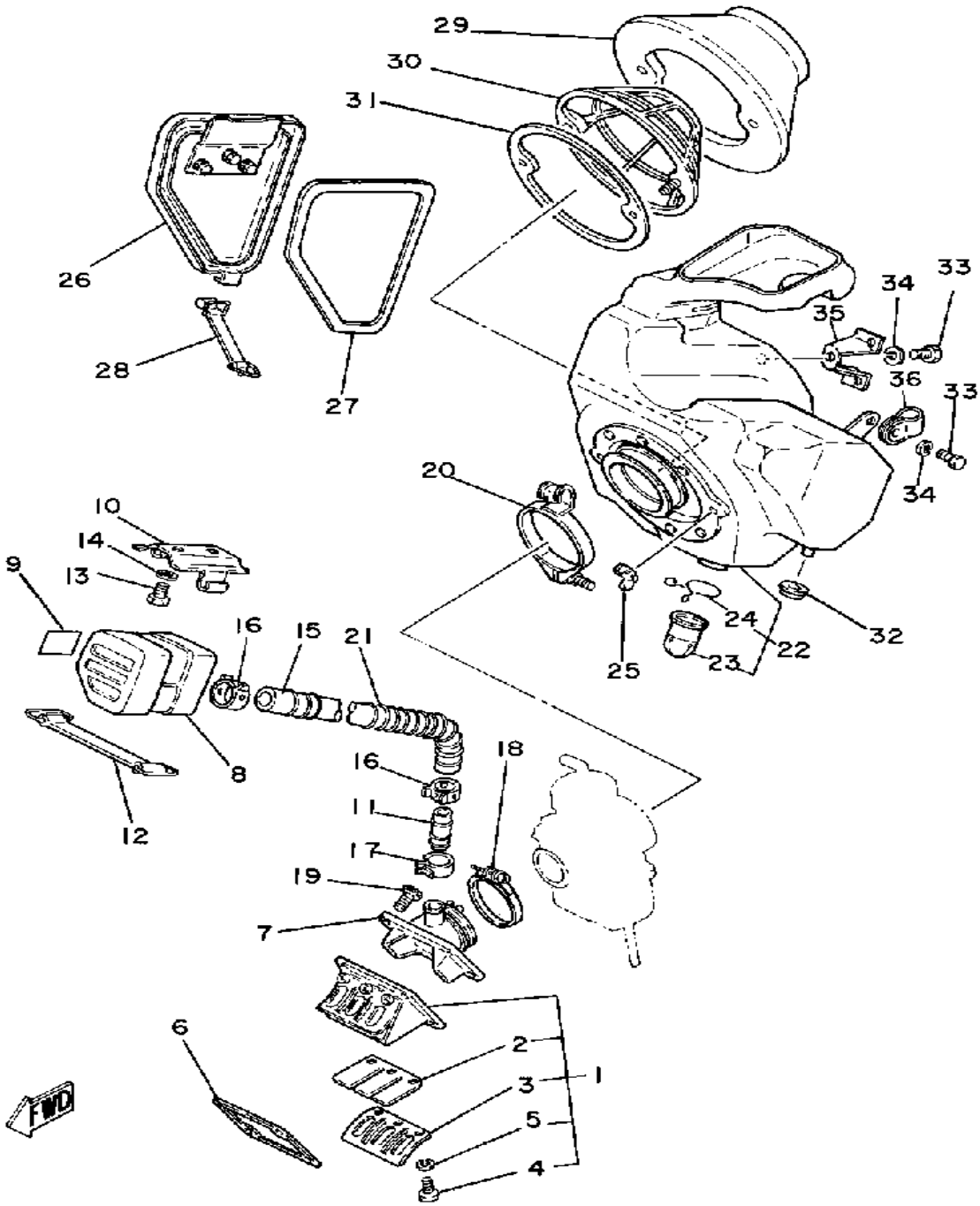

Ref. No.	Part Number	Description	Qty	Remarks
29	3R4-W1442-01-00	ELEMENT, AIR CLNR	1	
30	3R4-14458-00-00	GUIDE, ELEMENT	1	
31	(4V4-14459-00-00)	HOLDER, GUIDE	1	
32	90480-13398-00	GROMMET	1	
33	97313-06016-00	BOLT, HEXAGON	4	
34	92995-06100-00	WASHER, SPRING	4	
35	4V4-14484-00-00	PLATE, CLNR CS FTNG	1	
36	4V4-14499-00-00	STAY 2	1	

CARBURETOR

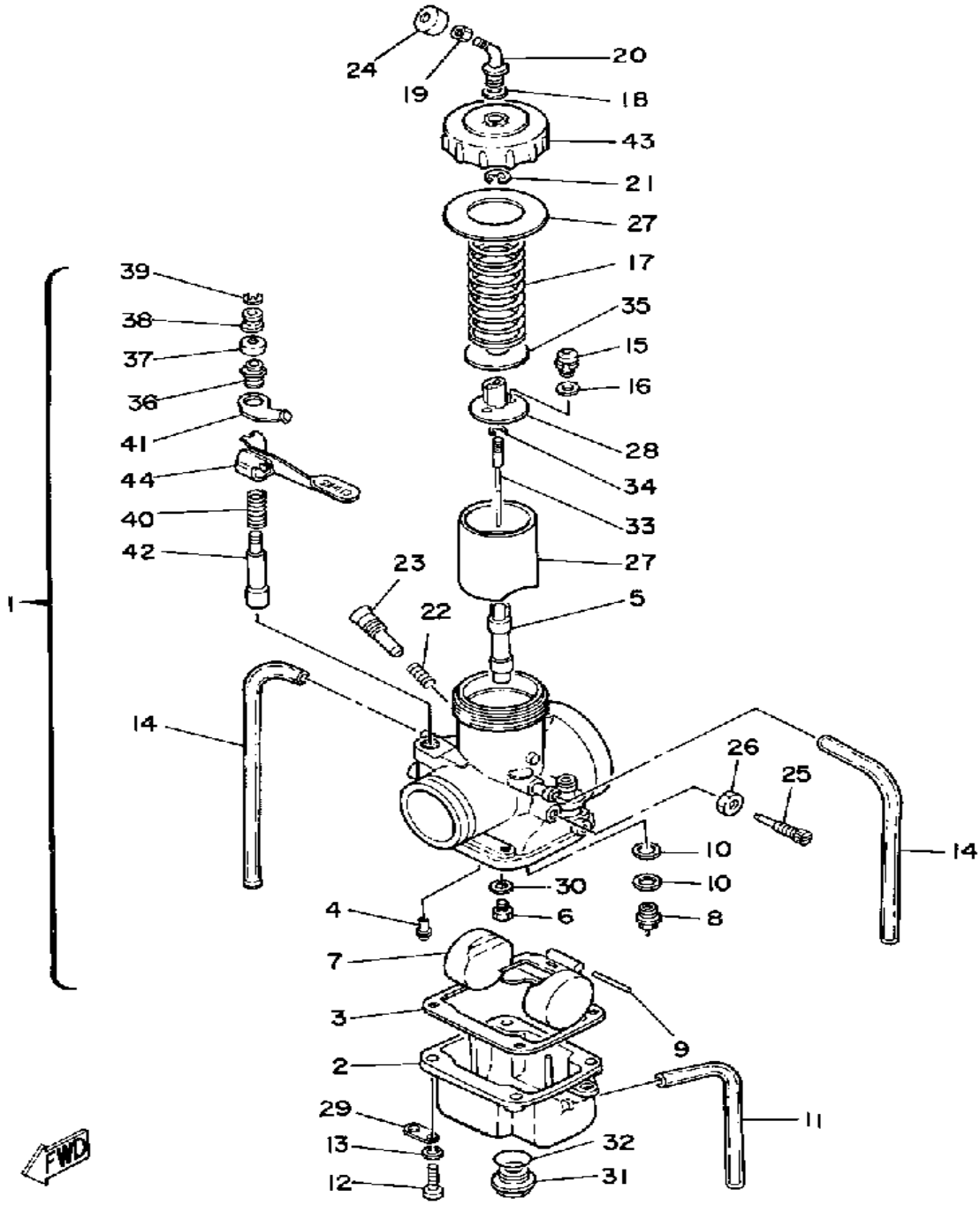

Ref. No.	Part Number	Description	Qty	Remarks
1	25Y-14101-00-00	CARBURETOR ASSEMBLY 1	1	
2	(3R4-14181-16-00)	BODY, FLOAT CHMBR 1	1	
3	363-14184-00-00	. GASKET, FLOAT CHMBR	1	
4	193-14142-50-00	. JET, PILOT (# 50)	1	
5	239-14141-32-00	. NOZZLE, MAIN (0-2)	1	
6	137-14143-78-00	. JET, MAIN (#390)	1	
	137-14143-80-00	. JET, MAIN (#400)	1	STD
	137-14143-82-00	. JET, MAIN (#410)	1	
7	2N7-14185-00-00	. FLOAT	1	
8	24X-14107-30-00	. NEEDLE VALVE SET (239-14190-30) (3.0)	1	
9	537-14186-00-00	. PIN, FLOAT	1	
10	239-14195-00-00	. WASHER, NEEDLE VALVE	2	
11	3Y3-14196-00-00	. PIPE, OVERFLOW	1	
12	98580-05016-00	. SCREW, PAN HEAD	4	
13	92990-05100-00	. WASHER, SPRING	4	
14	310-14197-00-00	. PIPE, AIRVENT	2	
15	98580-03008-00	. SCREW, PAN HEAD	2	
16	92902-03600-00	. WASHER	2	
17	363-14131-00-00	. SPRING, THROTTLE VALVE	1	
18	509-14198-00-00	. GASKET	1	
19	127-14161-00-00	. NUT, CABLE ADJUSTING	1	
20	23X-14106-00-00	. CABLE ADJUST SCREW SET	1	
21	363-14137-00-00	. CLIP	1	
22	137-14133-00-00	. SPRING, THRTL STOP	1	
23	26A-14104-00-00	. AIR SCREW SET (1W3-14123-00)	1	
24	1M1-14169-00-00	. CAP	1	
25	23X-14103-00-00	. THROTTLE SCREW SET	1	

CONTINUED ON NEXT FRAME ►

CARBURETOR

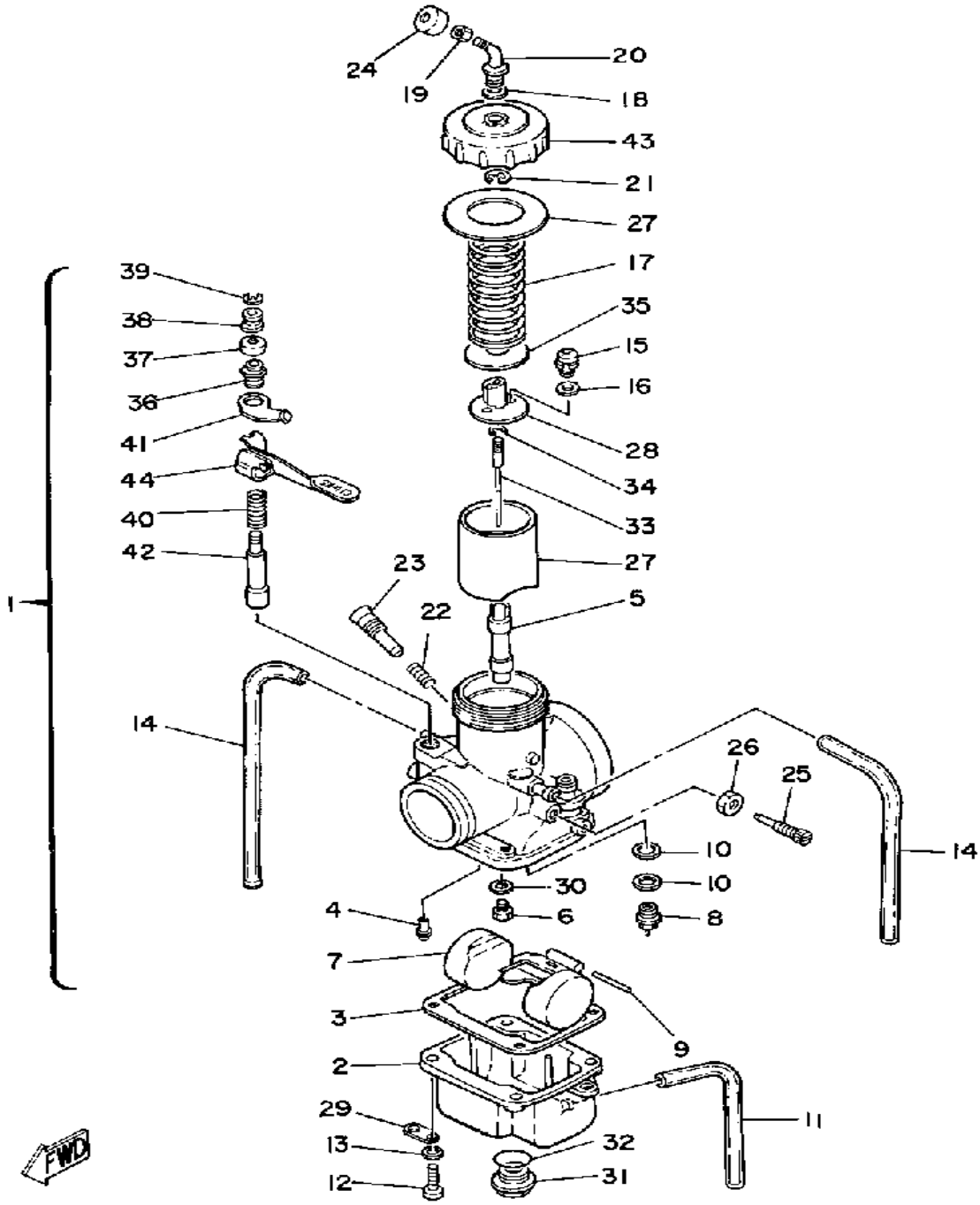

Ref. No.	Part Number	Description	Qty	Remarks
26	802-14161-00-00	. NUT, CABLE ADJUSTING ...	1	
27	(2X7-14112-20-00)	VALVE, THROTTLE 2 0	1	
28	509-14274-00-00	. CONNECTOR	1	
29	3R4-14146-00-00	. PLATE	1	
30	(2X7-14194-00-00)	RING	1	
31	510-14115-00-00	. PLUG, SCREW	1	
32	558-14147-00-00	. O-RING	1	
33	239-14116-34-00	. NEEDLE	1	
34	164-14137-00-00	. CLIP	1	
35	509-14136-00-00	. SEAT, SPRING	1	
36	802-14174-00-00	. CAP, PLUNGER	1	
37	(2X7-14173-00-00)	COVER, PLUNGER CAP	1	
38	737-14241-00-00	. BUSH	1	
39	737-14137-00-00	. CLIP	1	
40	256-14135-00-00	. SPRING, PLUNGER	1	
41	(1W3-14178-00-00)	PLATE, STARTER LVR	1	
42	1W1-14171-00-00	. PLUNGER, STARTER	1	
43	1W3-14158-00-00	. TOP, MIXING CHAMBER	1	
44	1W3-14175-00-00	. COVER, PLUNGER CAP (1W3-14173-00-00)	1	

EXHAUST

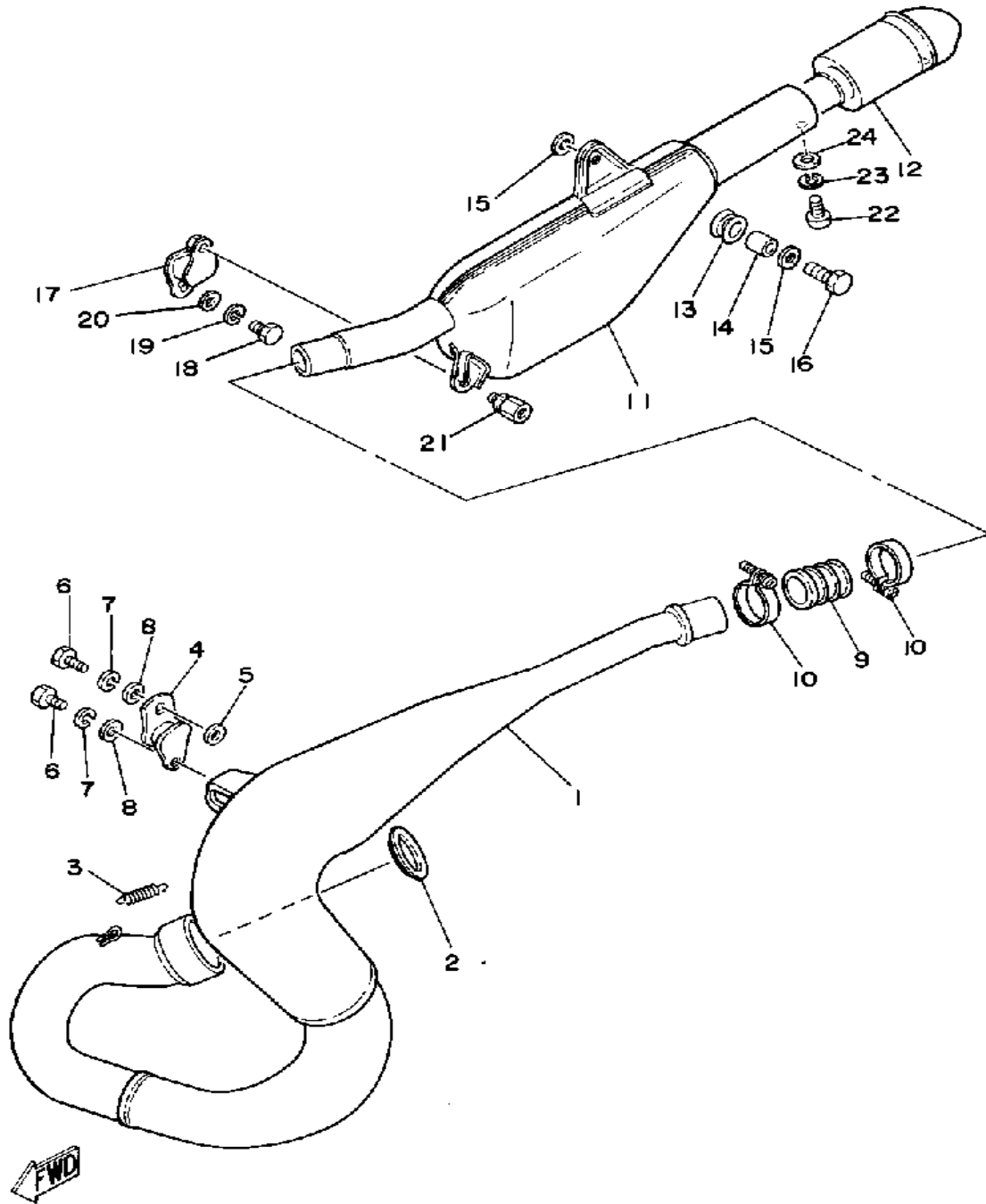

Ref. No.	Part Number	Description	Qty	Remarks
1	4V5-14610-00-00	EXHAUST PIPE ASSEMBLY L	1	
2	3R4-14613-00-00	GASKET, EXST PIPE	1	
3	90507-20030-00	SPRING, TENSION	3	
4	3R4-14781-03-00	STAY, MUFFLER 2 (3R4-14781-01)	1	
5	92990-08200-00	WASHER, PLAIN	1	
6	97313-08018-00	BOLT, HEXAGON (97301-08016)	2	
7	92990-08100-00	WASHER	2	
8	92901-08600-00	WASHER	2	
9	1M1-14714-00-00	GASKET, MUFFLER	1	
10	90460-43053-00	CLAMP, HOSE	2	
11	4V5-14753-00-00	SILENCER, EXHAUST	1	
12	4V5-14752-00-00	PIPE, OUTLET	1	
13	565-14747-00-00	DAMPER, MUFFLER	1	
14	90387-08258-00	COLLAR	1	
15	90201-085E6-00	WASHER PLATE	2	
16	90109-08512-00	BOLT	1	
17	565-14771-00-00	STAY, MUFFLER 1	1	
18	97313-06016-00	BOLT, HEXAGON	1	
19	92995-06100-00	WASHER, SPRING	1	
20	92901-06600-00	WASHER	1	
21	90109-06551-00	BOLT	1	
22	98580-06012-00	SCREW, PAN HEAD	1	
23	92995-06100-00	WASHER, SPRING	1	
24	92901-06600-00	WASHER	1	

CRANKCASE

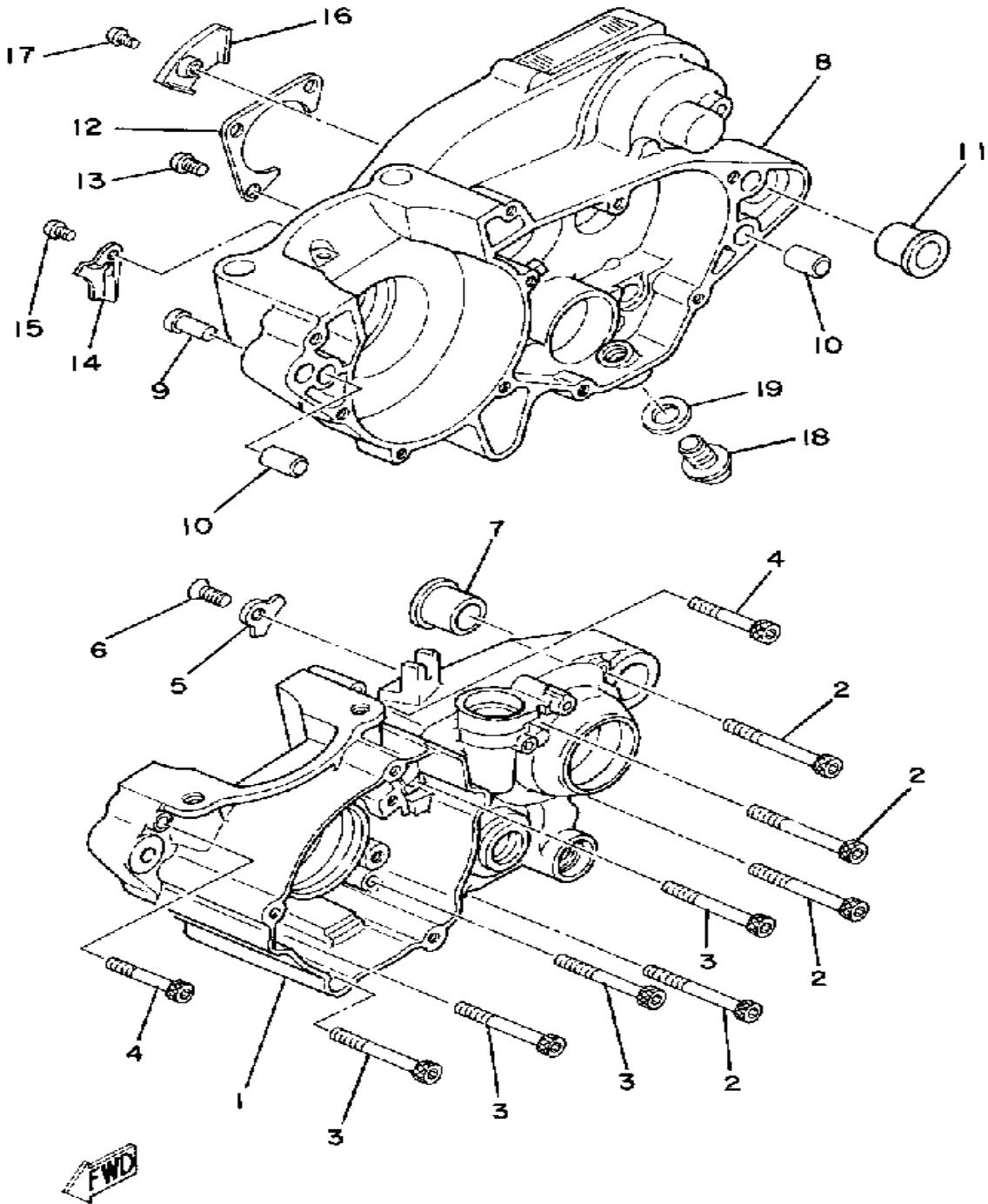

Ref. No.	Part Number	Description	Qty	Remarks
1	99999-01383-00	CRANKCASE 1	1	
2	91316-06060-00	BOLT	4	
3	91316-06055-00	BOLT, SOCKET HEAD	4	
4	91316-06040-00	BOLT, SOCKET HEAD	2	
5	3AK-15383-01-00	PLATE, BRNG COVER	1	
6	98603-06012-00	SCREW, OVAL HEAD (92701-06012)	1	
7	90387-16776-00	COLLAR	1	
8	3R4-W1512-01-00	CRANKCASE 2 (3R4-15121-01)	1	
9	90338-07011-00	PLUG, SPEC'L SHAPE	1	
10	99510-12016-00	PIN, DOWEL	4	
11	90387-16776-00	COLLAR	1	
12	3R4-15381-00-00	PLATE, BEARING COVER	1	
13	98580-06012-00	SCREW, PAN HEAD	3	
14	3R4-15118-00-00	HOLDER	1	
15	92501-08010-00	SCREW, PAN HEAD	1	
16	3R4-15113-00-00	PLATE	1	
17	98580-06012-00	SCREW, PAN HEAD	1	
18	90340-12097-00	PLUG, STRAIGHT SCREW	1	
19	90430-12207-00	GASKET	1	

CRANKCASE COVER

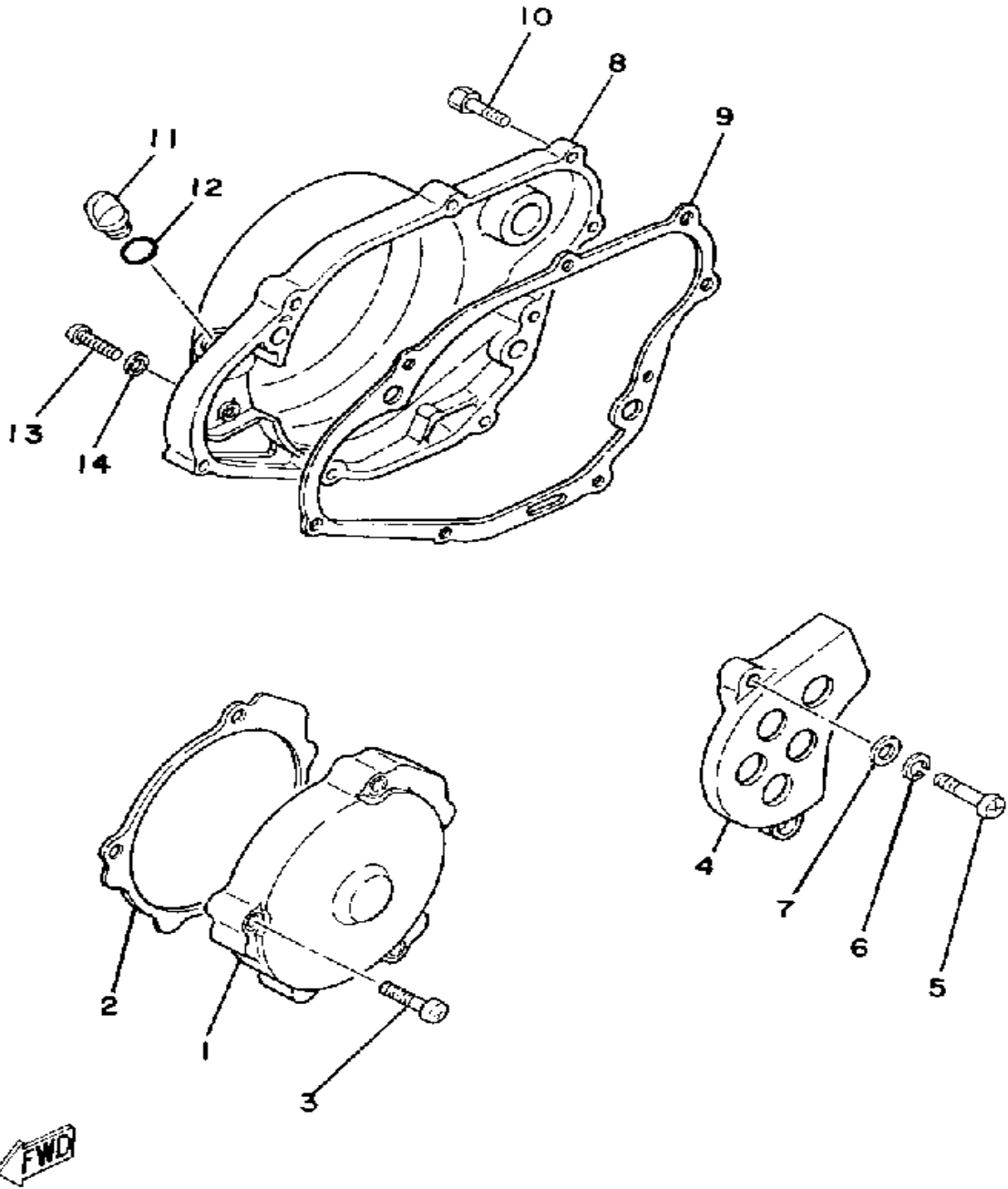

Ref. No.	Part Number	Description	Qty	Remarks
1	4V5-15411-00-00	COVER, CRANKCASE L	1	
2	4V5-15451-00-00	GASKET, CRCS COVER	1	
3	98506-06035-00	SCREW, PAN HEAD	3	
4	3R4-15421-00-00	COVER, CRANKCASE R	1	
5	98506-06025-00	SCREW, PAN HEAD	1	
6	92906-06100-00	WASHER, SPRING	1	
7	92906-06600-00	WASHER	1	
8	3R4-15431-02-00	COVER, CRANKCASE 3 (3R4-15431-00)	1	
9	3R4-15462-00-00	GASKET, CRCS CVR 3COVER 3	1	
10	91316-06025-00	BOLT	8	
11	1G8-15362-00-00	PLUG, OIL LEVEL	1	
12	93210-14104-00	O-RING	1	
13	98506-06008-00	SCREW, PAN HEAD (92506-06008-00)	1	
14	90430-06016-00	GASKET	1	

KICK STARTER

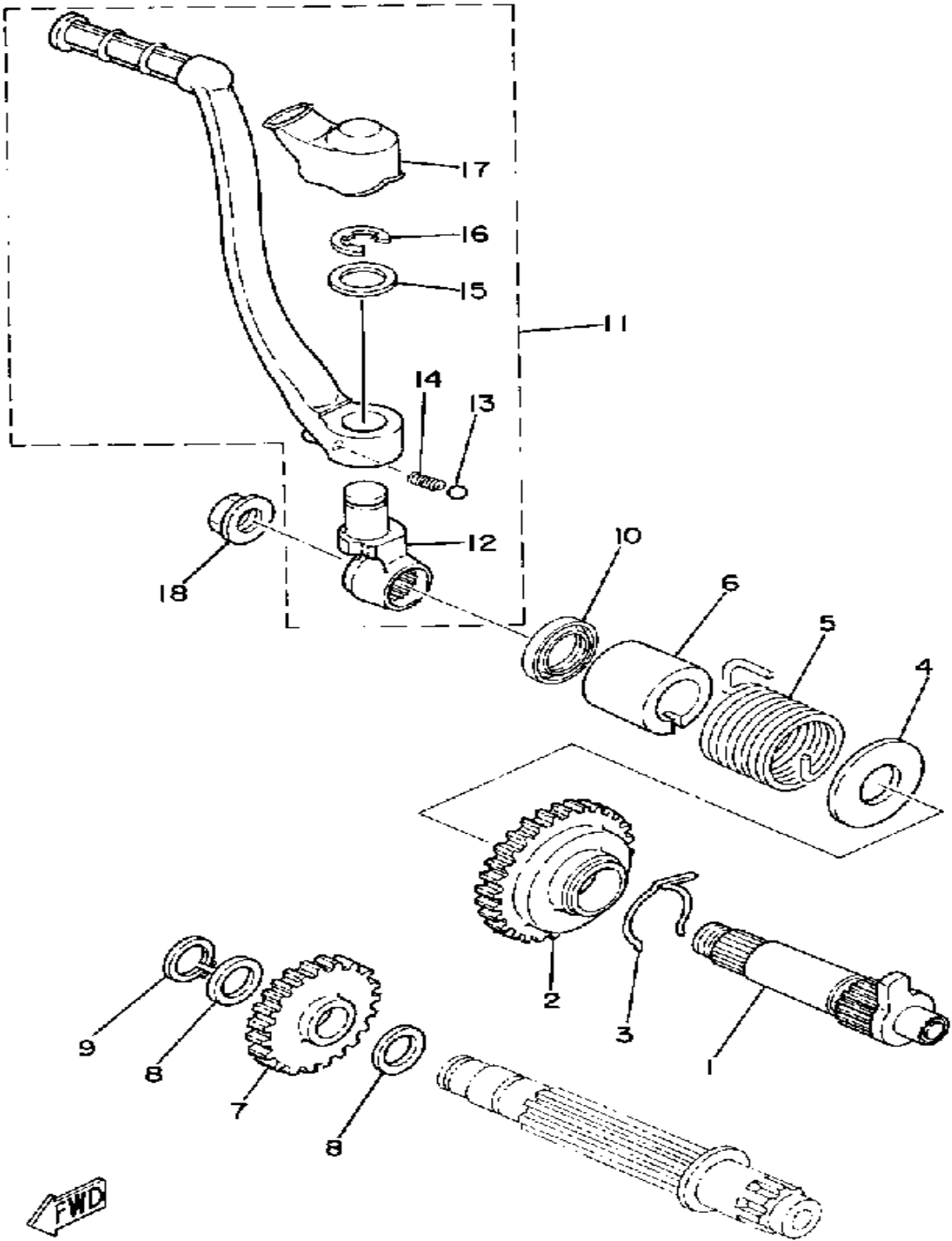

Ref. No.	Part Number	Description	Qty	Remarks
1	56A-15661-01-00	AXLE, KICK	1	
2	3R4-15641-00-00	GEAR, KICK	1	
3	90468-26048-00	CLIP	1	
4	90201-20358-00	WASHER, PLATE	1	
5	90508-30422-00	SPRING, TORSION	1	
6	3R4-15664-00-00	GUIDE, SPRING	1	
7	3R4-15651-00-00	GEAR, KICK IDLE	1	
8	90201-17545-00	WASHER, PLATE	2	
9	99009-17400-00	CIRCLIP	1	
10	93102-20309-00	SEAL, OIL	1	
11	3R4-15620-00-00	KICK CRANK ASSEMBLY	1	
12	3R4-15621-01-00	. BOSS, KICK CRANK	1	
13	93507-32031-00	. BALL	1	
14	90501-12081-00	. SPRING, COMPRESSION	1	
15	90201-15234-00	. WASHER, PLATE	1	
16	99006-10600-00	. CIRCLIP	1	
17	2K7-15618-00-00	. COVER, KICK LEVER	1	
18	90179-12244-00	NUT, SPEC'L SHAPE	1	

CLUTCH

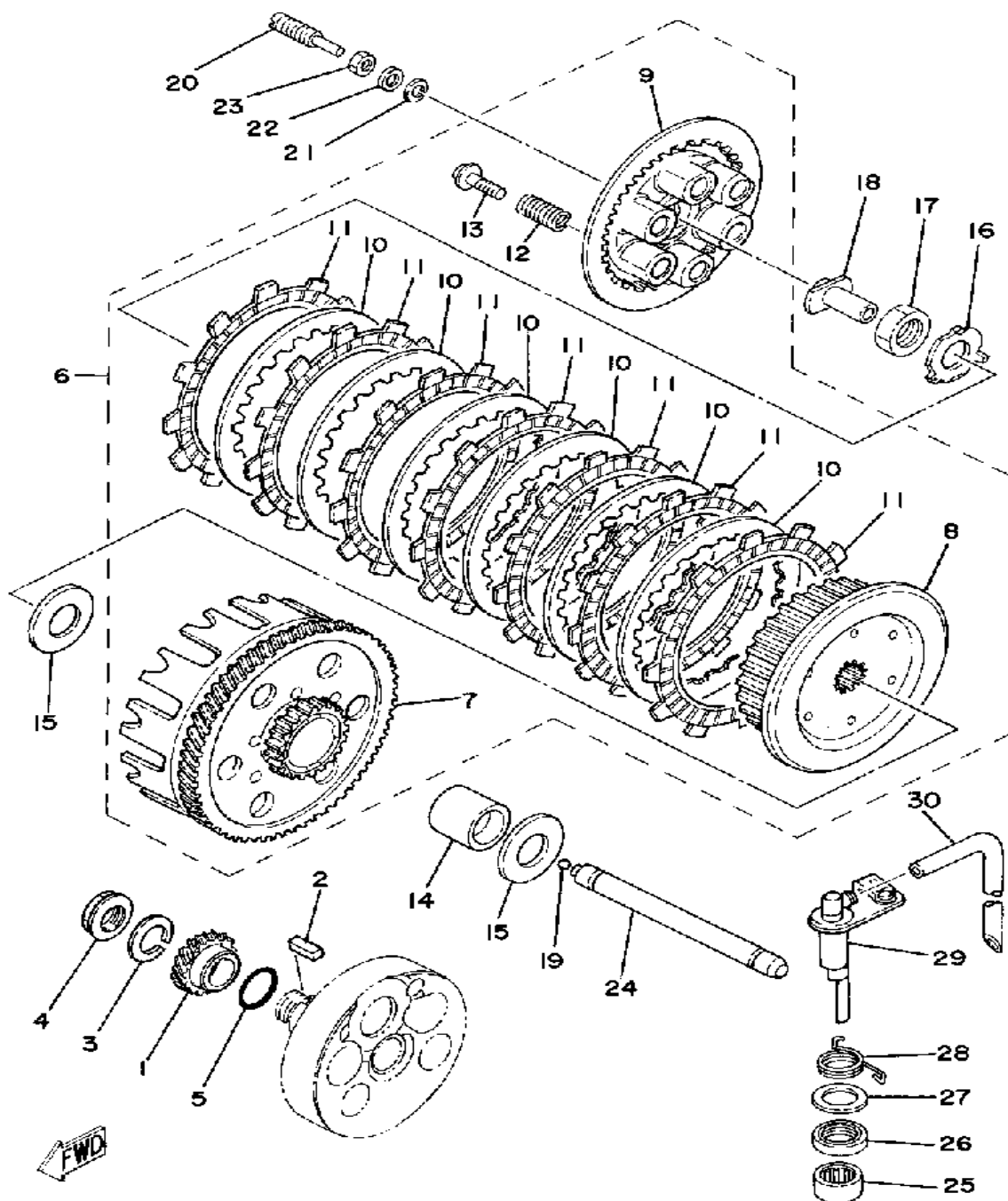

Ref. No.	Part Number	Description	Qty	Remarks
1	3R4-16111-00-00	GEAR, PRI DRIVE (24T)	1	
2	90282-07019-00	KEY, STRAIGHT	1	
3	92901-18100-00	WASHER, SPRING	1	
4	90170-18089-00	NUT, HEXAGON	1	
5	93210-29282-00	O-RING	1	
6	4V3-16300-00-00	CLUTCH ASSEMBLY (250H)	1	
7	3R4-16150-00-00	. PRI DRVN GEAR (63T)	1	
8	3R4-16371-00-00	. BOSS, CLUTCH	1	
9	1M1-16351-00-00	. PLATE, PRESSURE 1	1	
10	4H7-16325-00-00	. PLATE, CLUTCH 2	6	
11	4H7-16321-01-00	. PLATE, FRICTION	7	
12	90501-23138-00	. SPRING, COMPRESSION	6	
13	90159-06016-00	. SCREW, WITH WASHER	6	
14	2K7-16181-00-00	SPACER 1	1	
15	2K7-16154-00-00	PLATE, THRUST 1	2	
16	90215-20125-00	WASHER, LOCK	1	
17	90170-20255-00	NUT	1	
18	3R4-16356-00-00	ROD, PUSH 1	1	
19	93515-32029-00	BALL	1	
20	90149-08143-00	SCREW	1	
21	92990-08100-00	WASHER	1	
22	90201-087H6-00	WASHER, PLATE	1	
23	95311-08700-00	NUT	1	
24	2K7-16357-01-00	ROD, PUSH 2	1	
25	93315-21721-00	BEARING, CYLINDER.# 5	1	
26	93102-17004-00	OIL SEAL	1	
27	90201-17327-00	WASHER, PLATE	1	
28	90508-14423-00	SPRING, TORSION	1	
29	4V4-16380-00-00	PUSH LEVER ASSEMBLY	1	
30				

CONTINUED ON NEXT FRAME ➤

CLUTCH

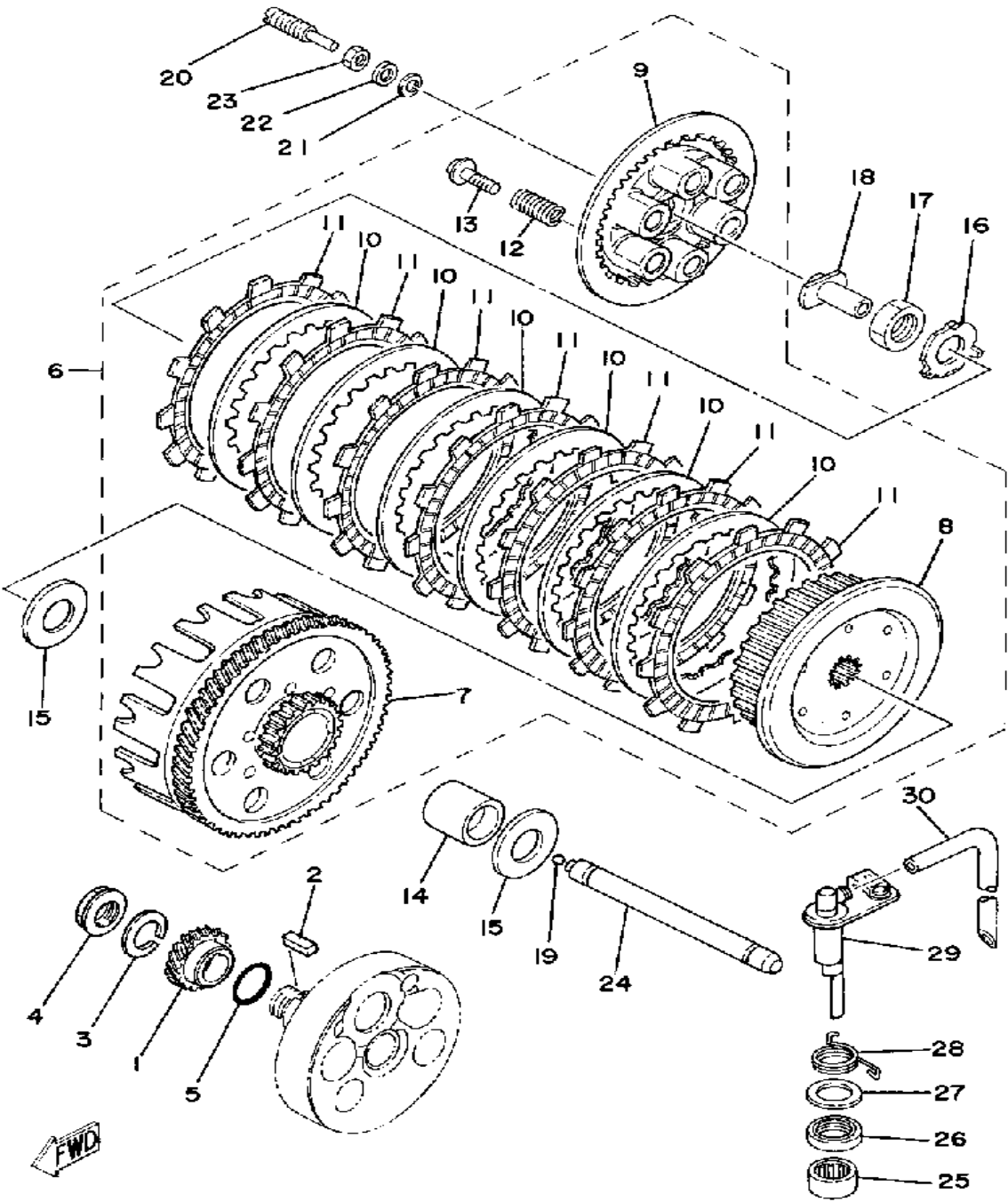

Ref. No.	Part Number	Description	Qty	Remarks
30	(90445-08577-00)	HOSE 0 1	1	

TRANSMISSION

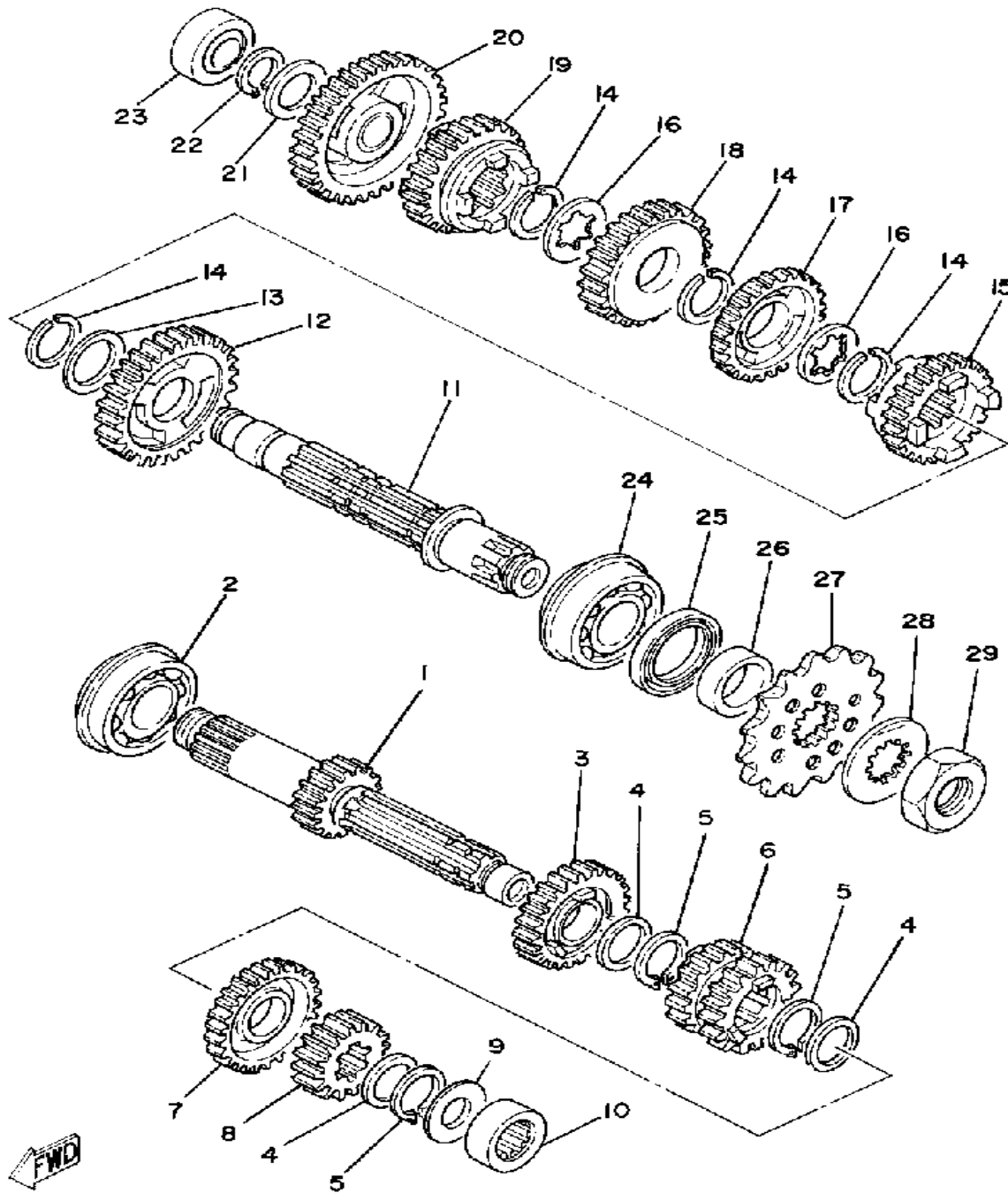

Ref. No.	Part Number	Description	Qty	Remarks
1	4V5-17411-00-00	AXLE, MAIN (12T)	1	
2	93306-20540-00	BEARING	1	
3	4V5-17151-00-00	GEAR, 5TH PINION (22T)	1	
4	90201-22555-00	WASHER, PLATE	3	
5	93410-22039-00	CIRCLIP	3	
6	4V5-17131-00-00	GEAR, 3RD PINION (16T, 20T)	1	
7	3R4-17161-03-00	GEAR, 6TH PINION (24T) (3R4-17121-00)	1	
8	4V5-17121-00-00	GEAR, 2ND PINION (15T)	1	
9	90201-17255-00	WASHER, PLATE	1	
10	93311-41734-00	BEARING, CYLINDER.# 1	1	
11	3R4-17421-00-00	AXLE, DRIVE	1	
12	4V5-17221-00-00	GEAR, 2ND WHEEL (30T)	1	
13	90201-253K0-00	WASHER, PLATE (T=1.0)	1	
14	93440-25084-00	CIRCLIP	4	
15	3R4-17261-02-00	GEAR, 6TH WHEEL (21T) (3R4-17261-01)	1	
16	90209-22082-00	WASHER (0.5T)	2	
17	4V5-17241-00-00	GEAR, 4TH WHEEL (25T)	1	
18	4V5-17231-00-00	GEAR, 3RD WHEEL (25T)	1	
19	4V5-17251-00-00	GEAR, 5TH WHEEL (23T)	1	
20	2X7-17211-00-00	GEAR, 1ST WHEEL	1	
21	90201-20278-00	WASHER, PLATE	1	
22	93410-20038-00	CIRCLIP	1	
23	93311-62035-00	BEARING, CYLINDER.# 1	1	
24	93306-20552-00	BEARING	1	
25	93102-32M07-00	OIL SEAL	1	
26	90387-25663-00	COLLAR	1	
27	93834-13030-00	SPROCKET, DRIVE 13T (23X1746130)	1	STD

CONTINUED ON NEXT FRAME ►

TRANSMISSION

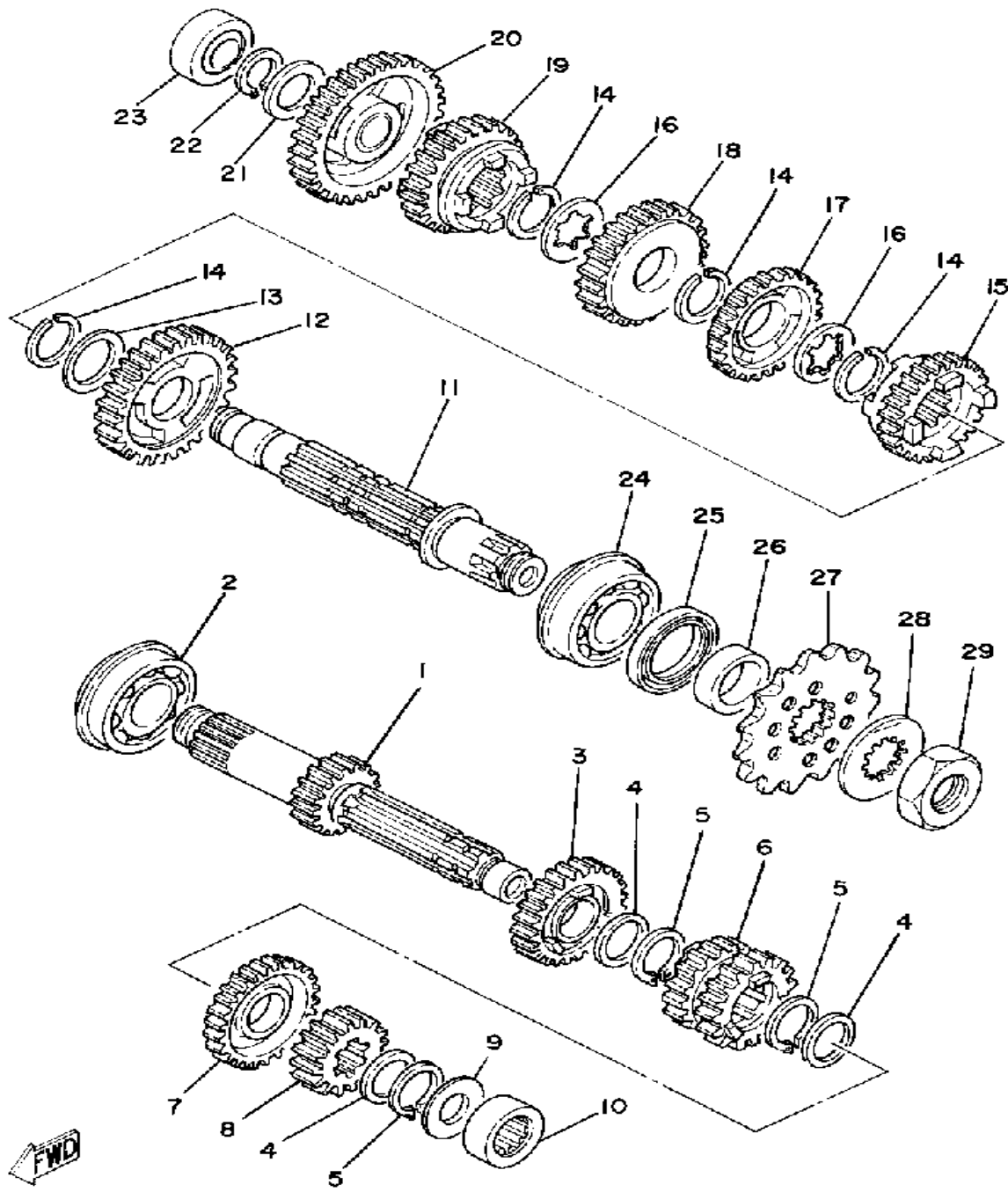

Ref. No.	Part Number	Description	Qty	Remarks
27	93834-14051-00	SPROCKET, DRIVE (23X-17461-40)	1	ALTERNATE PARTS
	93834-15078-00	SPROCKET, DRIVE	1	ALTERNATE PARTS
28	90215-21239-00	WASHER, LOCK	1	
29	90179-20255-00	NUT	1	

SHIFT CAM - FORK

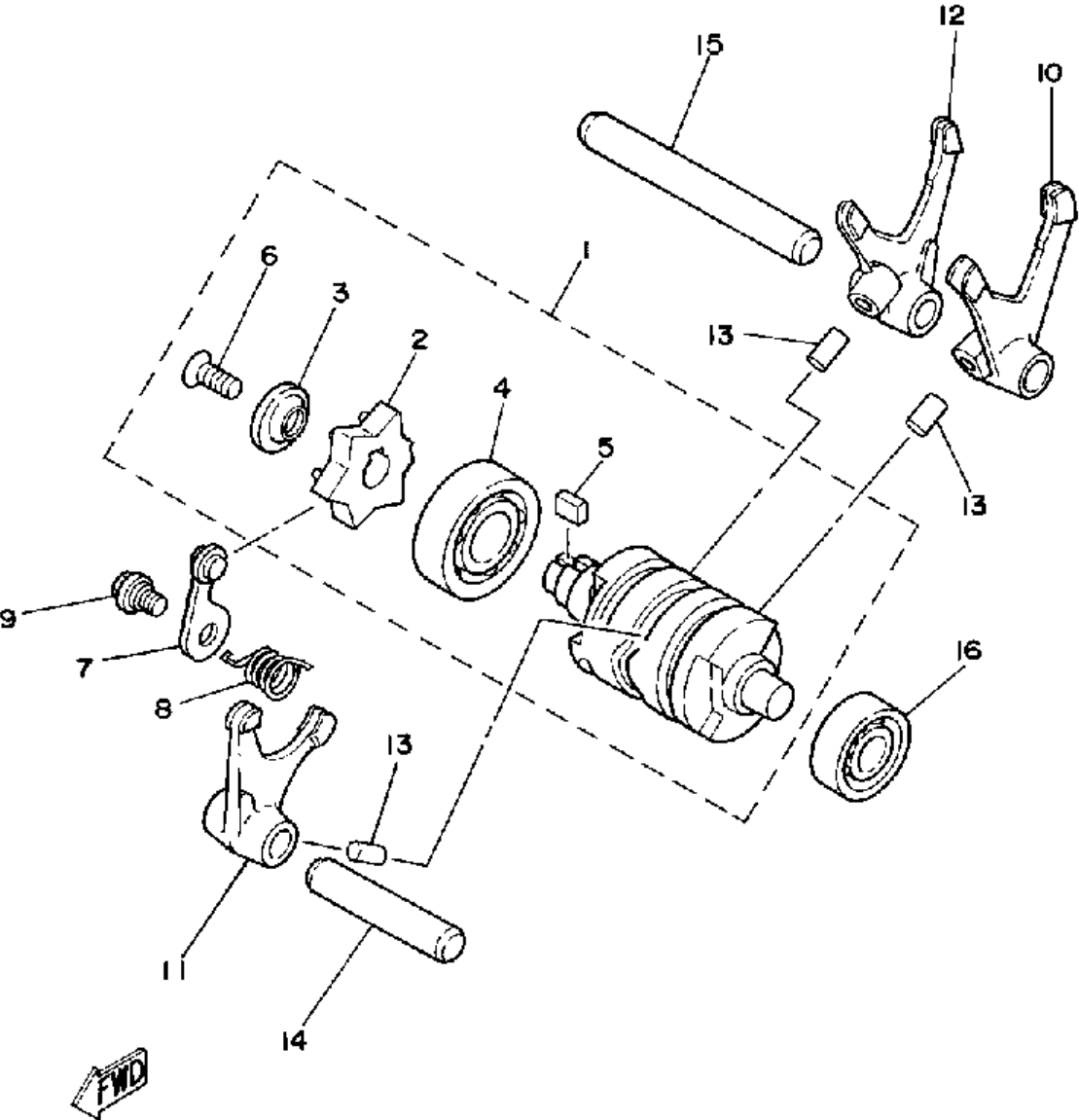

Ref. No.	Part Number	Description	Qty	Remarks
1	25Y-18540-00-00	SHIFT CAM ASSEMBLY	1	
2	3R4-18185-00-00	. SEGMENT	1	
3	3R4-18561-00-00	. PLATE, SIDE 1	1	
4	93306-00406-00	. BEARING (B6004Z)	1	
5	90282-04036-00	. KEY, STRAIGHT	1	
6	98701-05016-00	. SCREW, FLAT HEAD	1	
7	3R4-18140-00-00	STOPPER LEVER ASSEMBLY	1	
8	90508-26421-00	SPRING, TORSION	1	
9	50W-21631-00-00	BOLT 1	1	
10	3R4-18511-01-00	FORK, SHIFT 1	1	
11	3R4-18512-01-00	FORK, SHIFT 2	1	
12	3R4-18513-01-00	FORK, SHIFT 3 (250G)	1	
13	93606-14154-00	PIN, DOWEL	3	
14	(4V4-18531-00-00)	BAR, SHIF FRK GDE 1	1	
15	4V4-18535-00-00	BAR, SHIF FRK GDE 2 (250H)	1	
16	93306-20110-00	BEARING (B6201)	1	

SHIFT SHAFT - PEDAL

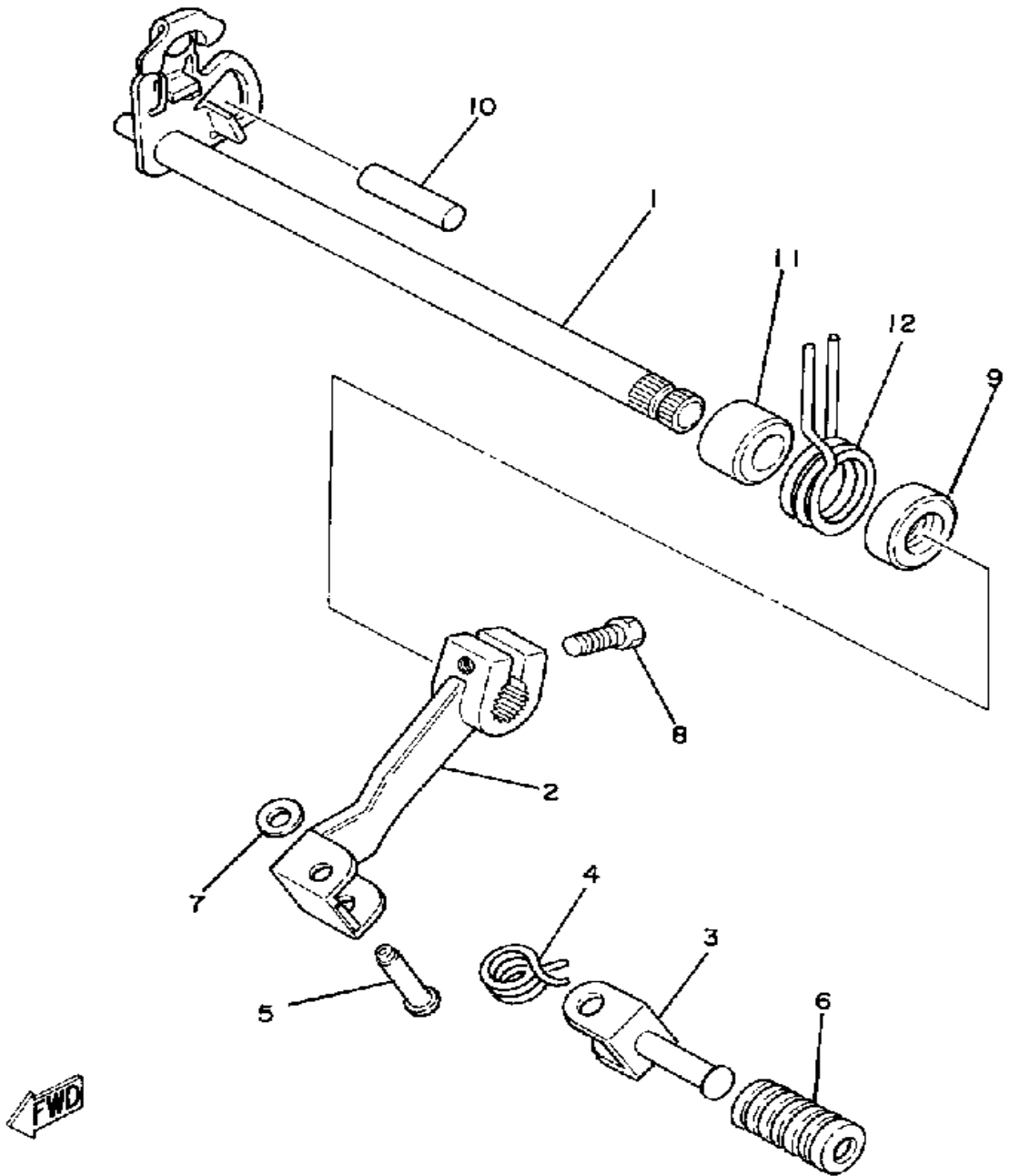

Ref. No.	Part Number	Description	Qty	Remarks
1	23X-18101-01-00	SHIFT SHAFT ASSEMBLY 1	1	
2	5X6-18110-00-00	PEDAL, SHIFT	1	
3	3R8-18162-00-00	PEDAL, SHIFT	1	
4	90508-20415-00	SPRING, TORSION	1	
5	90243-08019-00	PIN (90243-08017)	1	
6	1W6-18113-00-00	COVER, SHIFT PEDAL	1	
7	90201-06042-00	WASHER, PLATE	1	
8	97011-06020-00	BOLT	1	
9	93102-12321-00	OIL SEAL, SD-TYPE	1	
10	93608-25150-00	PIN, DOWEL	1	
11	90560-12171-00	SPACER	1	
12	90508-32374-00	SPRING, TORSION	1	

FRAME

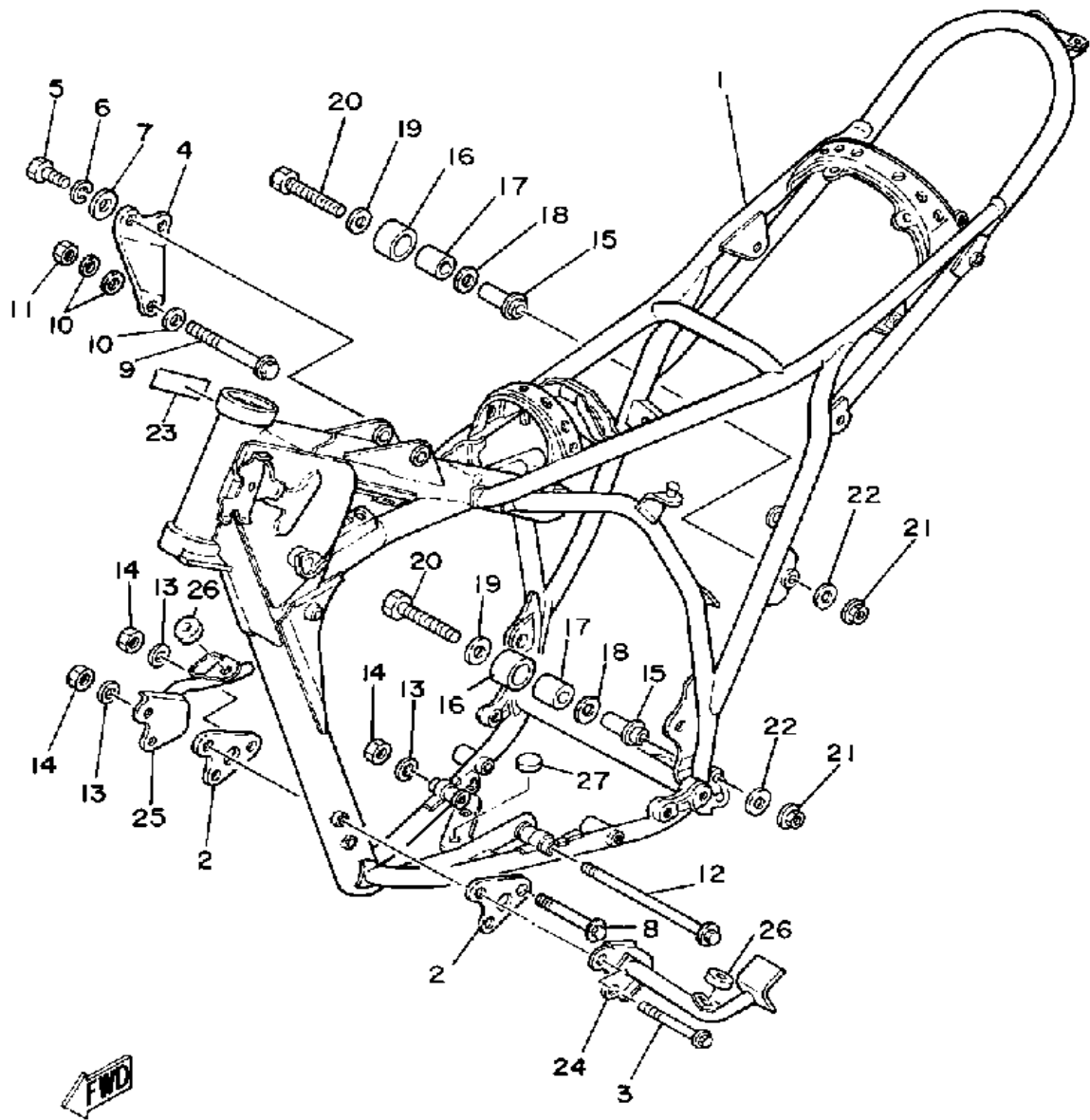

Ref. No.	Part Number	Description	Qty	Remarks
1	(4V5-21110-01-33)	FRAME	1	
2	3R4-21415-00-00	BRACKET, FRT UPR 1	2	
3	95811-08080-00	BOLT, FLANGE	2	
4	(4V3-21425-00-00)	BRACKET, REAR UPR 1	1	
5	97013-08025-00	BOLT	2	
6	92990-08100-00	WASHER	2	
7	92901-08600-00	WASHER	2	
8	95811-08075-00	BOLT, FLANGE	1	
9	95811-10045-00	BOLT, FLANGE	1	
10	92990-10200-00	WASHER, PLAIN	3	
11	95601-10100-00	NUT, U (95602-10100-00)	1	
12	95811-08170-00	BOLT, FLANGE	1	
13	92990-08200-00	WASHER, PLAIN	4	
14	90185-08089-00	NUT, SELF-LOCKING	4	
15	2K7-2148A-00-00	SHAFT	2	
16	30X-22178-00-00	TENSIONER	2	
17	4V4-22184-00-00	BUSH	2	
18	90201-13202-00	WASHER, PLATE	2	
19	90201-08753-00	WASHER, PLATE	2	
20	97313-08055-00	BOLT, HEXAGON	2	
21	95712-08300-00	NUT, LOCK	2	
22	90201-08638-00	WASHER, PLATE	2	
23	(3R4-2139W-00-00)	COVER	1	
24	4V5-2147A-00-33	GUARD, ENGINE 1	1	
25	4V5-2147E-00-33	GUARD, ENGINE 2	1	
26	2J5-21732-00-00	SEAL 1	2	
27	22W-24181-00-00	DAMPER, LOCATING 1	2	

FRONT FENDER - REAR FENDER

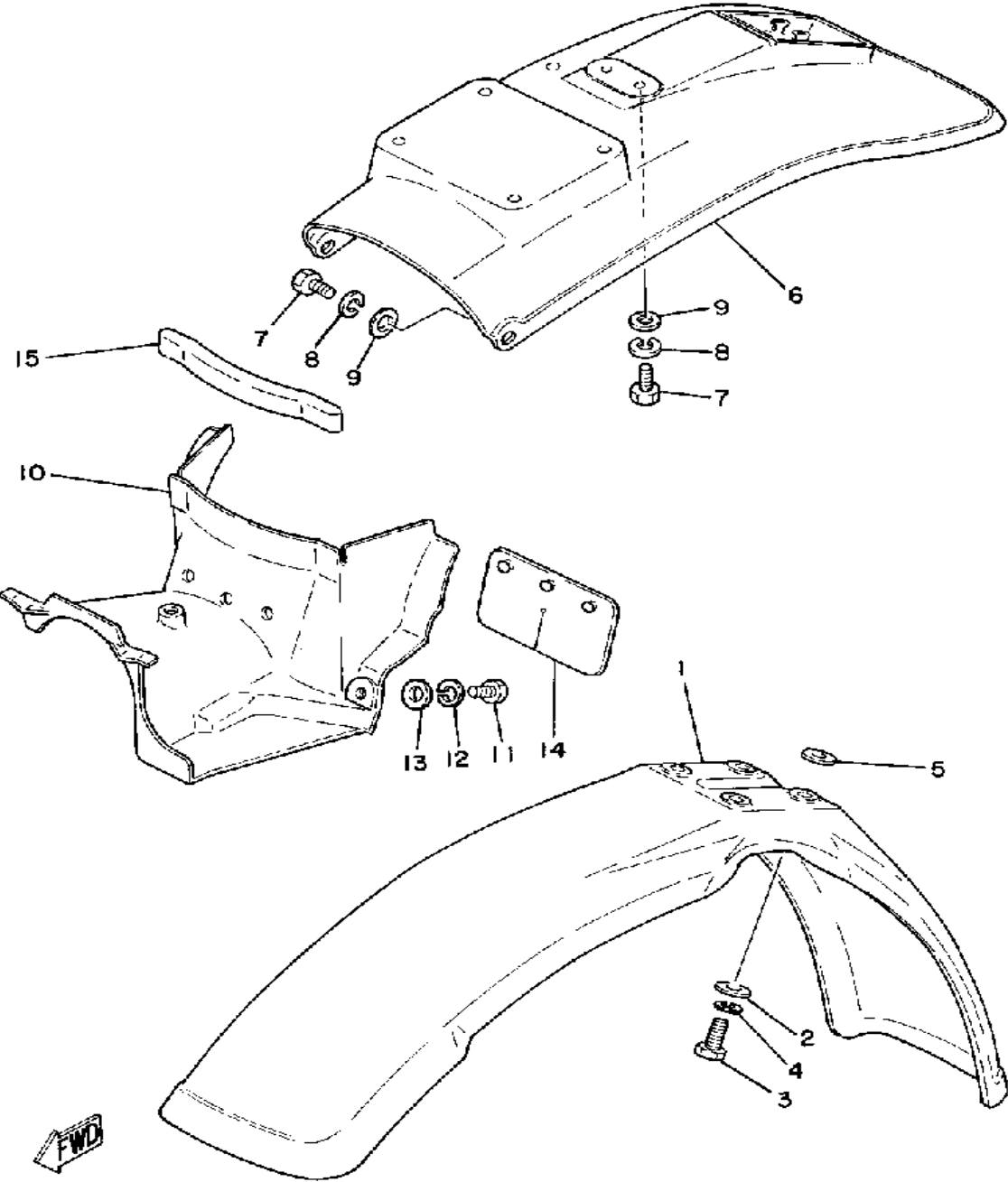

Ref. No.	Part Number	Description	Qty	Remarks
1	5X6-21511-11-00	FENDER, FRONT	1	
2	90201-06067-00	WASHER, PLATE	4	
3	97023-06020-00	BOLT (3XF)	4	
4	92995-06100-00	WASHER, SPRING	4	
5	90209-06187-00	WASHER	4	
6	4V5-21610-00-00	FENDER, REAR	1	
7	97016-06016-00	BOLT	4	
8	92906-06100-00	WASHER, SPRING	4	
9	90201-06067-00	WASHER, PLATE	4	
10	4V5-21629-00-00	GUARD, MUD	1	
11	97313-06016-00	BOLT, HEXAGON	2	
12	92995-06100-00	WASHER, SPRING	2	
13	90201-06067-00	WASHER, PLATE	2	
14	1M1-21621-00-00	FLAP	1	
15	565-21746-00-00	DAMPER	1	

SIDE COVER

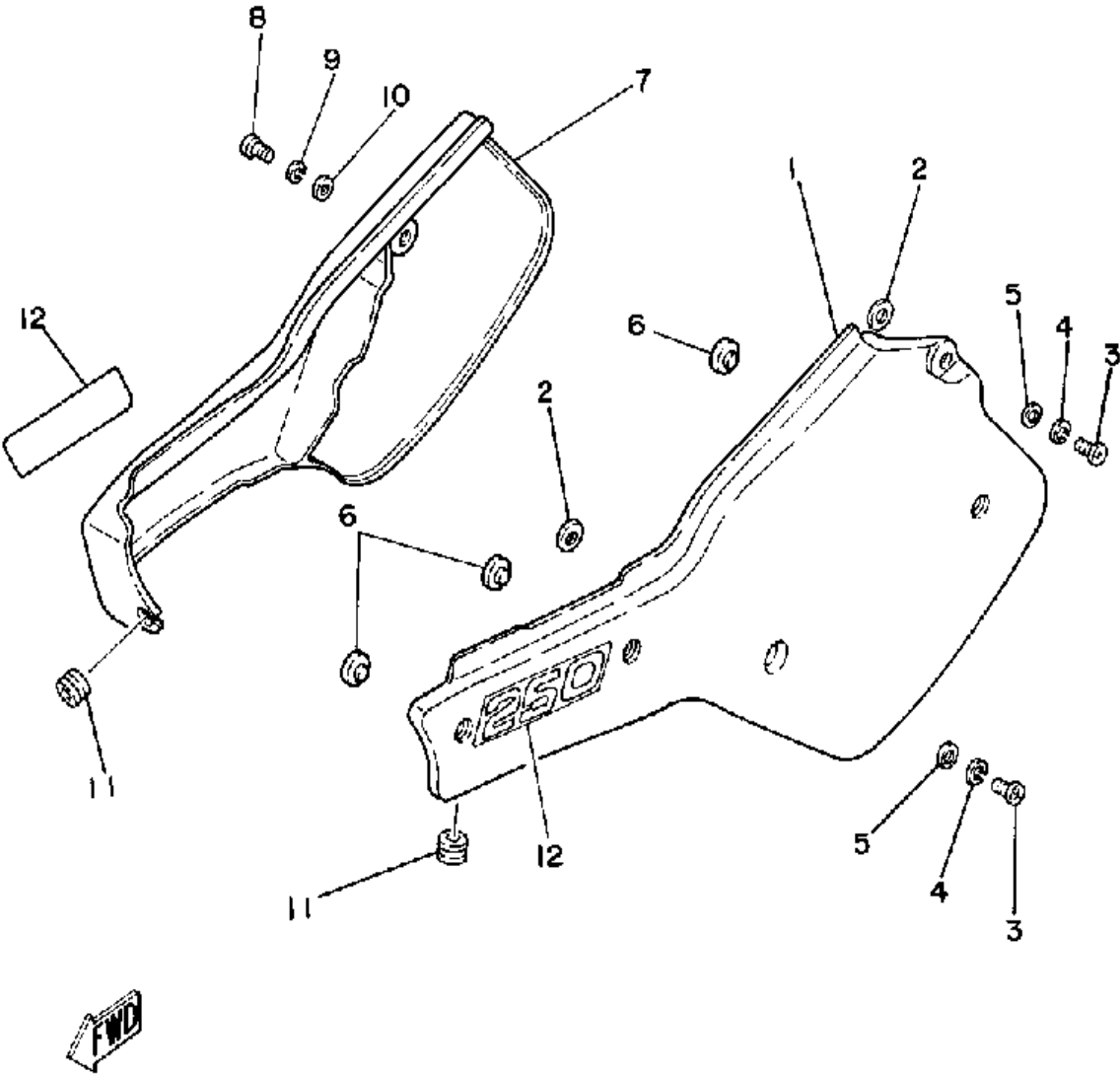

Ref. No.	Part Number	Description	Qty	Remarks
1	(4V5-21711-00-26)	COVER, SIDE 1	1	
2	92990-08200-00	WASHER, PLAIN	2	
3	98503-06014-00	SCREW, PAN HEAD (92502-06016)	2	
4	92995-06100-00	WASHER, SPRING	2	
5	90201-06571-00	WASHER, PLATE	2	
6	22W-24181-00-00	DAMPER, LOCATING 1	3	
7	4V5-21721-00-26	COVER, SIDE 2	1	
8	98503-06014-00	SCREW, PAN HEAD (92502-06016)	1	
9	92995-06100-00	WASHER, SPRING	1	
10	90201-06571-00	WASHER, PLATE	1	
11	90480-12053-00	GROMMET	2	
12	4V5-21737-00-00	EMBLEM	2	

REAR ARM

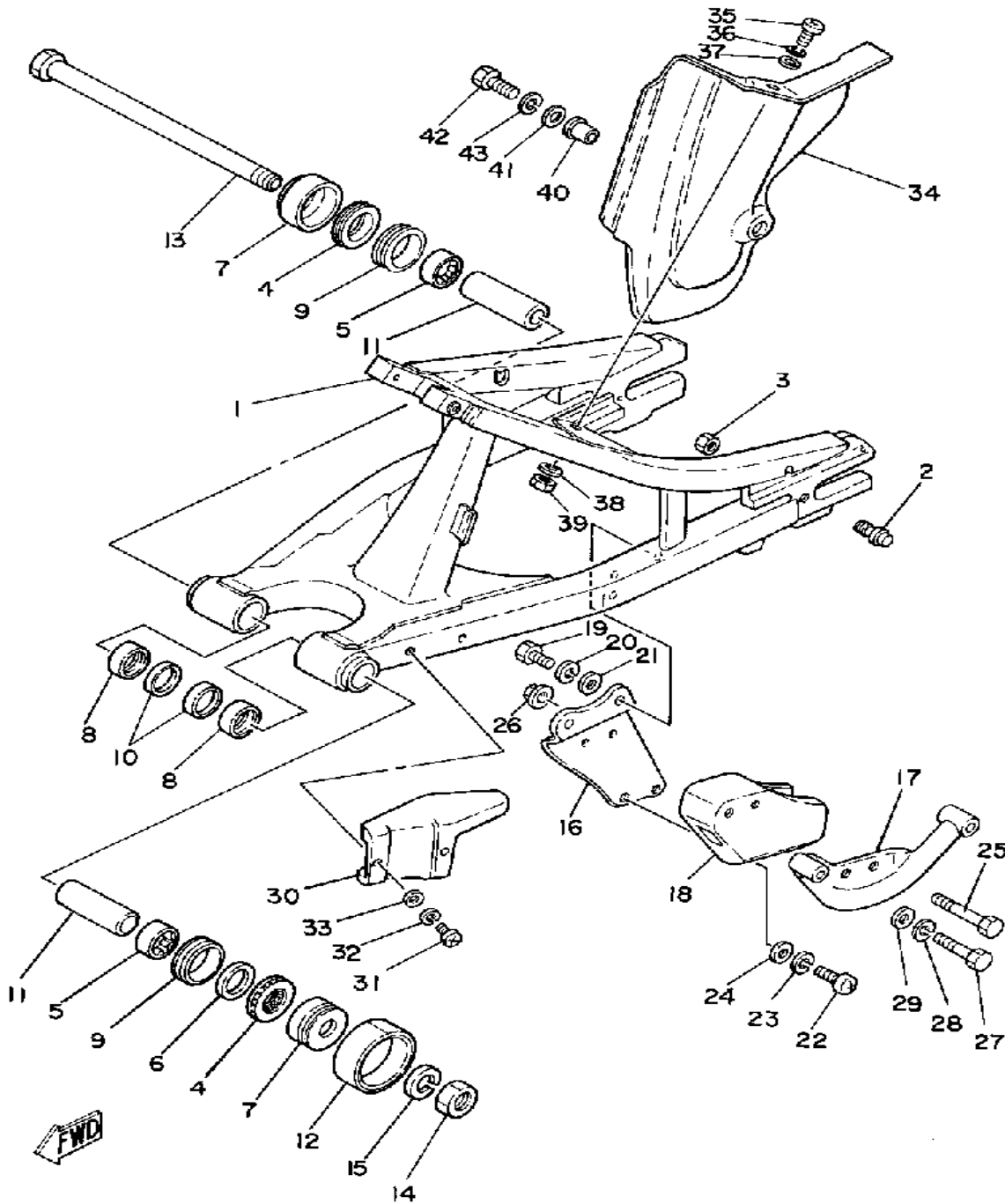

Ref. No.	Part Number	Description	Qty	Remarks
1	(4V5-22110-00-35)	REAR ARM	1	
2	90109-08599-00	BOLT	2	
3	95701-08500-00	NUT, FLANGE	2	
4	93342-22208-00	BEARING, FLAT # 2	2	
5	93317-22214-00	BEARING, CYLINDER.# 7	2	
6	648-45533-00-03	SHIM	1	
7	3R4-22129-00-00	COVER, THRUST 2	2	
8	90386-22097-00	BUSH, SPEC'L NYLON	2	
9	93108-35004-00	OIL SEAL (35-41-8)	2	
10	93109-22018-00	OIL SEAL, SDO-TYPE	2	
11	90380-16077-00	BUSH, SOLID	2	
12	431-22151-03-00	SEAL, GUARD	1	
13	3R4-22141-00-00	SHAFT, PIVOT	1	
14	90170-16111-00	NUT, HEXAGON	1	
15	92901-16100-00	WASHER, SPRING	1	
16	2X4-22179-00-00	ARM, TENSIONER	1	
17	3R5-22153-00-00	GUARD, CHAIN	1	
18	2X4-22199-00-00	SUPPORT, CHAIN	1	
19	97313-08018-00	BOLT, HEXAGON (97301-08016)	1	
20	92990-08100-00	WASHER	1	
21	92901-08600-00	WASHER	1	
22	98580-06020-00	SCREW	2	
23	92995-06100-00	WASHER, SPRING	2	
24	92901-06600-00	WASHER	2	
25	97313-06050-00	BOLT	2	
26	95701-06300-00	NUT, NYLON	2	
27	97313-08035-00	BOLT, HEXAGON	2	
28	92990-08100-00	WASHER	2	
29	92901-08600-00	WASHER	2	

CONTINUED ON NEXT FRAME ➤

REAR ARM

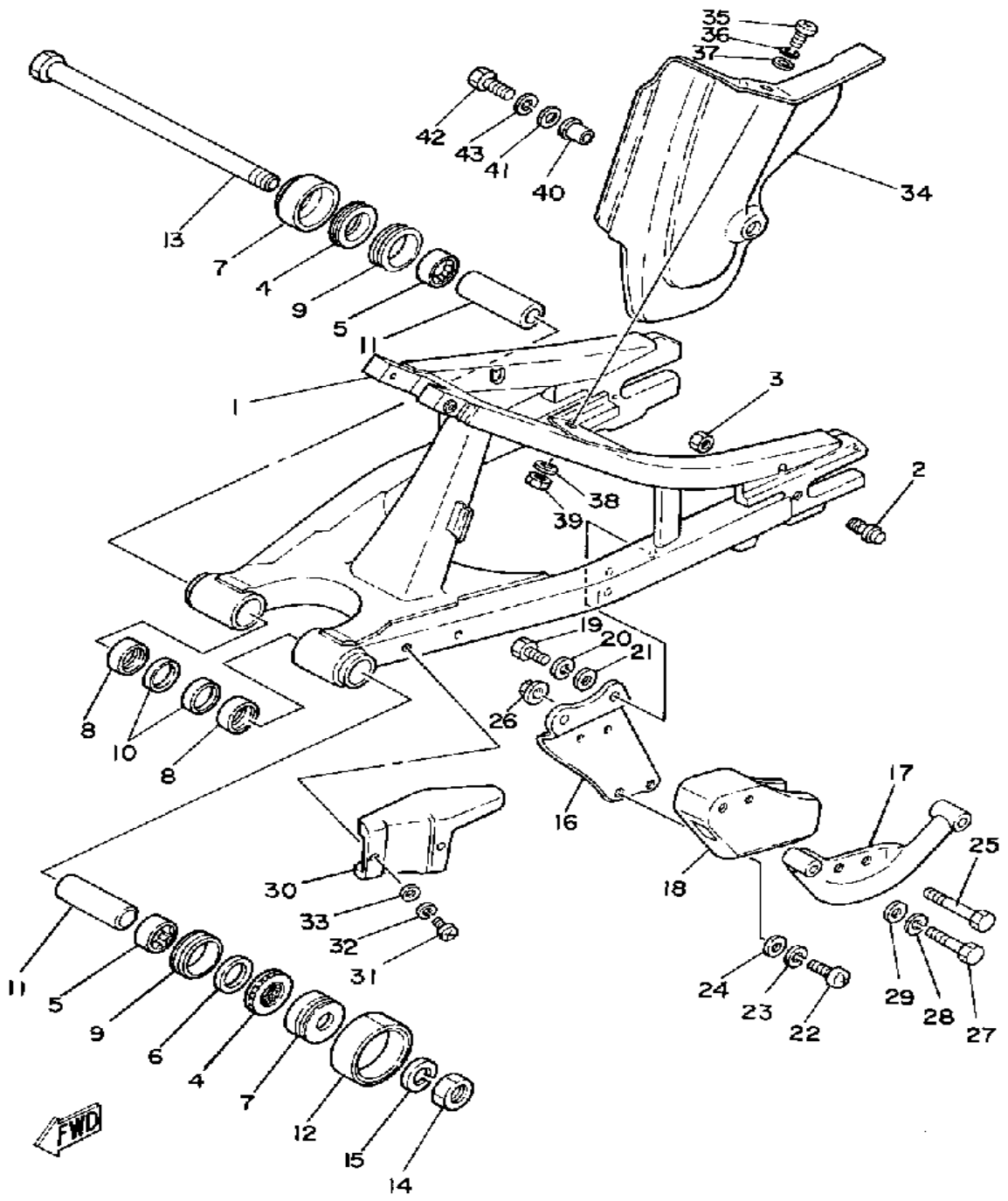

Ref. No.	Part Number	Description	Qty	Remarks
30	3R4-22147-00-00	PROTECTOR, CHAIN	1	
31	98580-05010-00	SCREW, PAN HEAD	2	
32	92990-05100-00	WASHER, SPRING	2	
33	92990-05200-00	WASHER, PLAIN	2	
34	4V5-22311-00-00	CASE, CHAIN	1	
35	98580-06020-00	SCREW	1	
36	92995-06100-00	WASHER, SPRING	1	
37	92901-06600-00	WASHER	1	
38	90201-06067-00	WASHER, PLATE	1	
39	95601-06100-00	NUT, U	1	
40	90560-08066-00	SPACER	1	
41	92990-08200-00	WASHER, PLAIN	1	
42	97313-08020-00	BOLT, HEXAGON	1	
43	92990-08100-00	WASHER	1	

REAR SUSPENSION

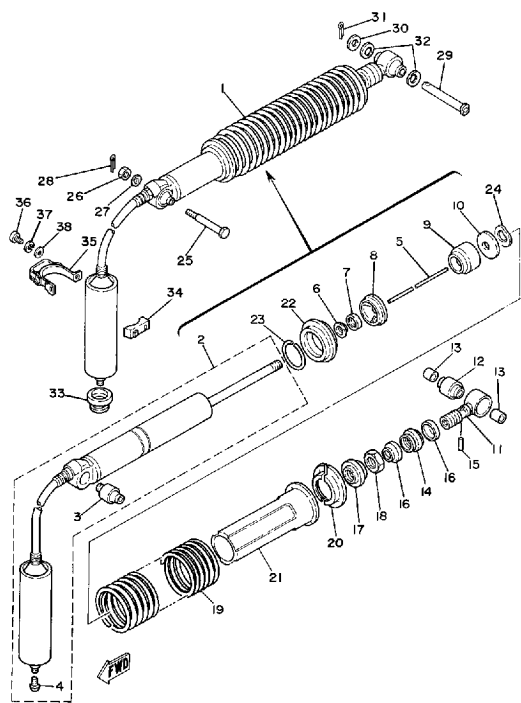

Ref. No.	Part Number	Description	Qty	Remarks
1	(4V5-22210-00-00)	SHK/ABS ASSEMBLY, REAR	1	
2	(4V5-22401-00-00)	DAMPER SUB-ASSEMBLY.	1	
3	1YW-22216-00-00	. . BUSH, RR SHOCK ABS	1	
4	98511-04006-00	. . SCREW, PAN HEAD (98501-04005)	1	
5	(3R4-22489-00-00)	ROD, PUSH	1	
6	23X-22475-00-00	. SEAL, DUST	1	
7	23X-22475-00-00	. SEAL, DUST	1	
8	26A-22472-00-00	. CAP, CASE	1	
9	(1W1-22493-00-00)	BUMP, STOP	1	
10	3R4-22228-00-00	. SUPPORT, BUMP STOP	1	
11	3R4-22409-00-00	. UPPER BRKT SUB ASSEMBLY	1	
12	3R4-22226-00-00	. BUSH, SHOCK ABS LWR	1	
13	90380-12051-00	. BUSH, SOLID	2	
14	5X3-22497-00-00	. NUT, ADJUSTING	1	
15	93604-26132-00	. PIN, DOWEL	1	
16	3R4-22221-01-00	. COVER	2	
17	3R4-22213-00-00	. SEAT, SPRING UPPER	1	
18	90170-20320-00	. NUT	1	
19	(4V5-22212-00-00)	SPRING	1	
	(4V5-22212-10-00)	SPRING, MXS SOFT	1	
	4V5-22212-20-00	. SPRING, MXS HARD	1	
20	3R4-22214-01-00	. GUIDE, SPRING 1 (3R4-22214-00)	2	
21	3R4-22224-00-00	. GUIDE, SPRING 2	1	
22	3R4-22223-00-00	. SEAT, SPRING LOWER	1	
23	93440-50078-00	. CIRCLIP, OUTER	1	
24	90206-14067-00	. WASHER, WAVE	1	
25	90109-10550-00	BOLT (90109-10453-00)	1	

CONTINUED ON NEXT FRAME ►

REAR SUSPENSION

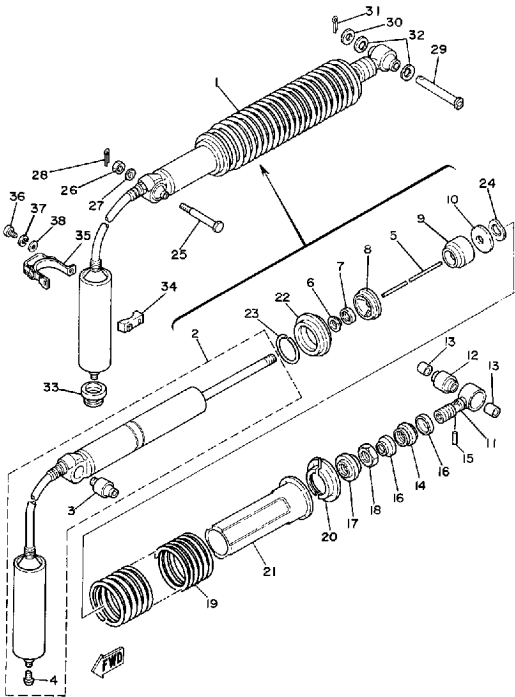

Ref. No.	Part Number	Description	Qty	Remarks
26	95303-10700-00	NUT	1	
27	92990-10600-00	WASHER, PLATE	1	
28	91490-20025-00	PIN, SPLIT	1	
29	90240-12074-00	PIN, CLEVIS	1	
30	92990-12600-00	WASHER, PLATE	1	
31	91401-30030-00	PIN, COTTER	1	
32	1W1-22128-00-00	COVER, THRUST 1	2	
33	90480-22263-00	GROMMET	1	
34	3R4-22261-00-00	DAMPER, SUB TANK	1	
35	4V4-22262-01-00	HOLDER, SUB TANK (250H) ..	1	
36	98503-06014-00	SCREW, PAN HEAD (92502-06016)	1	
37	92995-06100-00	WASHER, SPRING	1	
38	92901-06600-00	WASHER	1	

STEERING

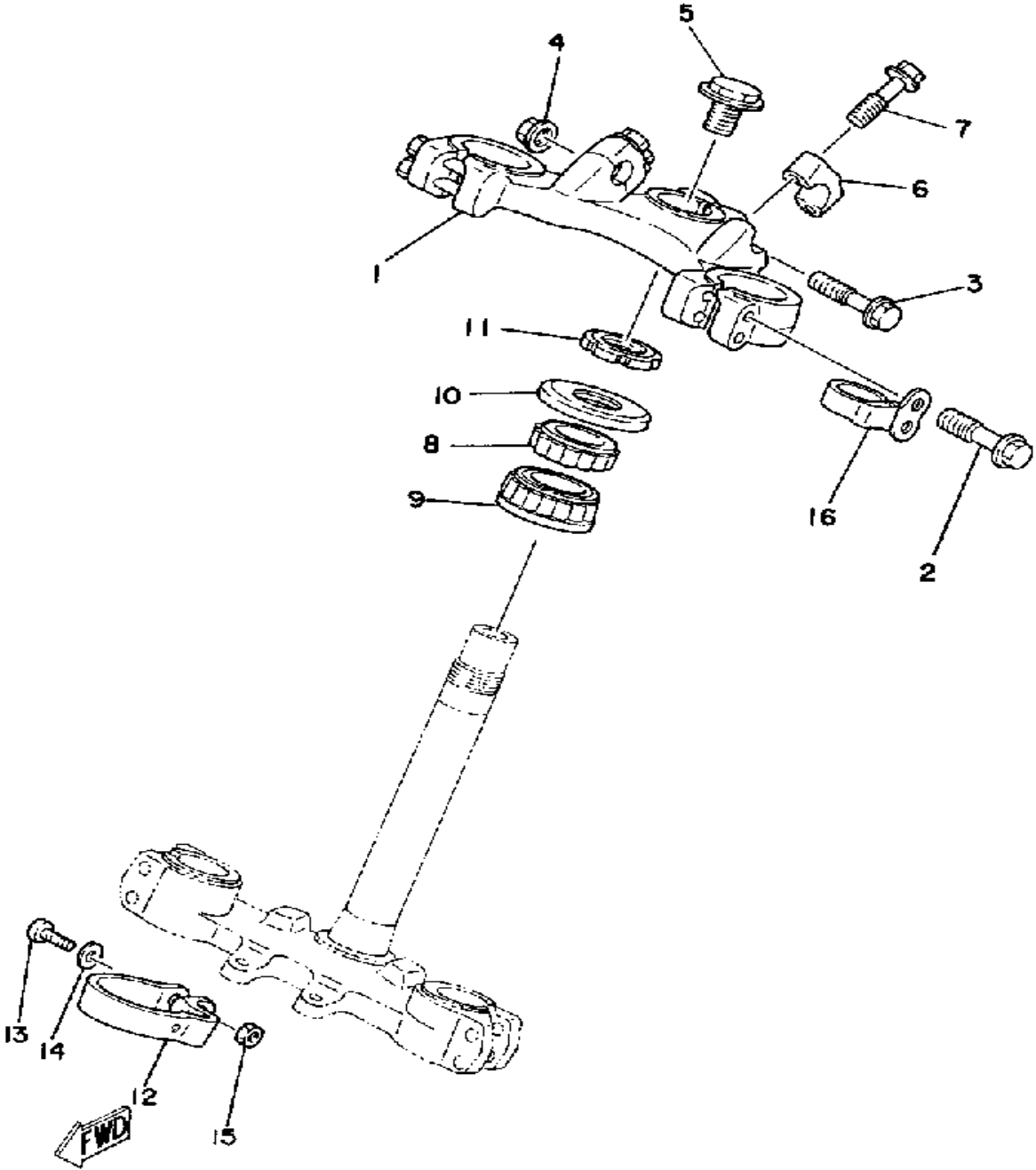

Ref. No.	Part Number	Description	Qty	Remarks
1	1W4-23435-00-98	CROWN, HANDLE	1	LOW GLOSS BLK
2	90105-08091-00	BOLT, WASHER BASED	4	
3	95811-08055-00	BOLT, FLANGE	1	
4	95701-08500-00	NUT, FLANGE	1	
5	90105-14136-00	BOLT, WASHER BASED	1	
6	1E6-23441-00-00	HOLDER, HANDLE UPR	2	LOW GLOSS BLK
7	95321-08035-00	UNAVAILABLE IN PRICE BOOK	4	
8	93332-00001-00	BEARING	1	
9	93332-00008-00	BEARING	1	
10	3HE-23416-00-00	COVER, BALL RACE 2	1	
11	90179-25033-00	NUT	1	
12	1W2-23318-00-00	HOLDER, CABLE 1	1	
13	98501-05018-00	SCREW, PAN HEAD	1	
14	92901-05600-00	WASHER, PLATE	1	
15	95380-05600-00	NUT	1	
16	3R4-23389-00-00	GUIDE, CABLE	1	

FRONT FORK

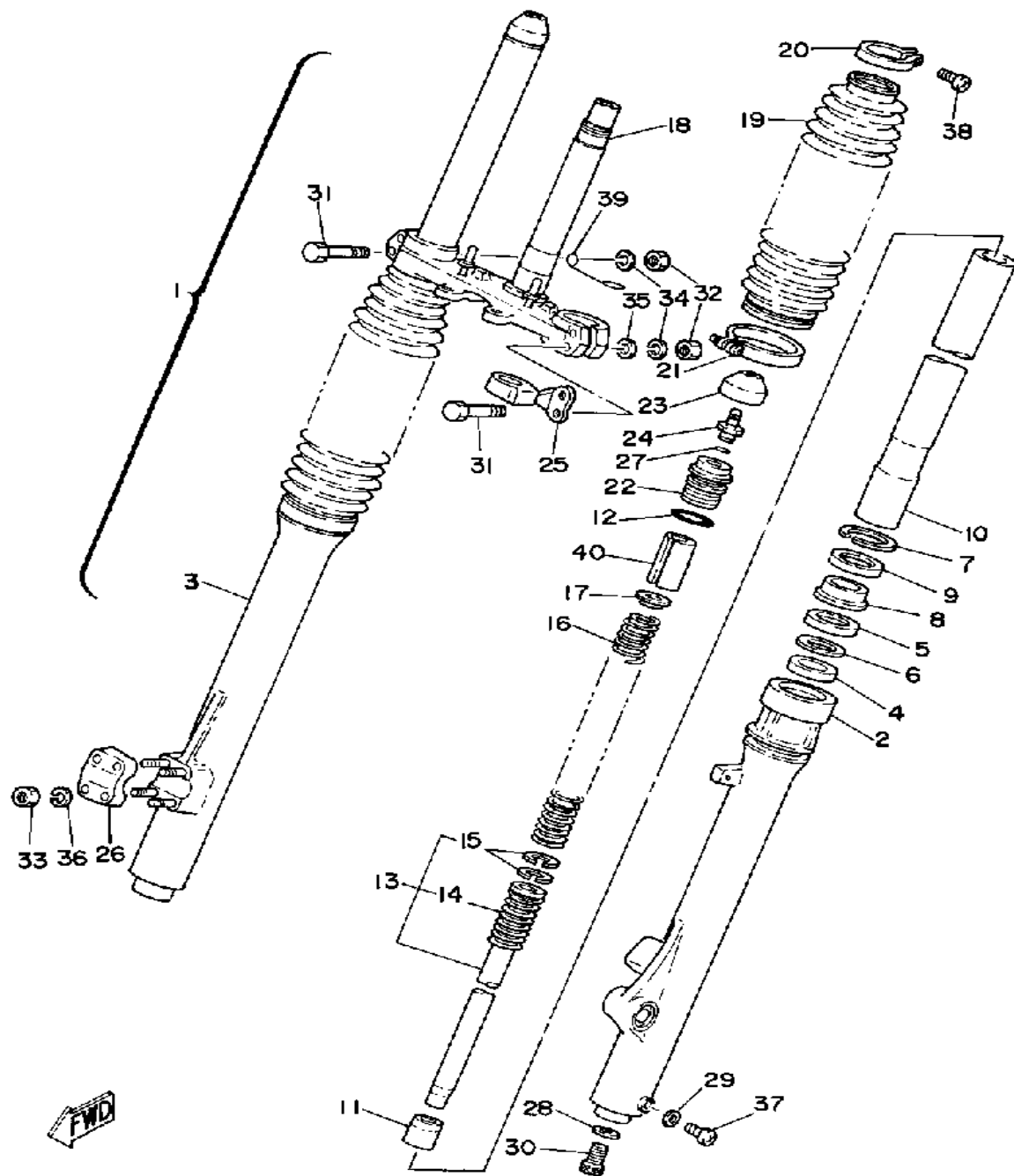

Ref. No.	Part Number	Description	Qty	Remarks
1	(4V5-23101-L0-00)	FRONT FORK ASSEMBLY	1	
2	(4V5-23126-L0-00)	TUBE, OUTER 1	1	
3	(4V5-23136-L0-00)	TUBE, OUTER 2	1	
4	2YK-23125-00-00	. METAL, SLIDE 1	2	
5	3EN-23145-00-00	. OIL SEAL	2	
6	4V2-23146-L0-00	. WASHER, OIL SEAL	2	
7	3R4-23153-00-00	. RING, SNAP	2	
8	3R4-23144-00-00	. SEAL, DUST	2	
9	3R4-23148-00-00	. COVER, DUST SEAL	2	
10	(4V2-23110-L0-00)	INNER TUBE 1	2	
11	(3R4-23173-L0-00)	SPINDLE, TAPER	2	
12	1W4-23114-L0-00	. GASKET	2	
13	(4V5-23170-L0-00)	CYLINDER, FRTFRK	2	
14	(1W4-23151-L0-00)	SPRING, REBOUND	2	
15	4V2-23157-L0-00	. . RING, PISTON FRTFRK	4	
16	(4V5-23141-10-00)	SPRING, FRTFRK SOFT	2	
	(4V5-23141-20-00)	SPRING, FRTFRK HARD	2	
	(4V5-23141-L0-00)	SPRING, FRONT FORK	2	
17	1W4-23142-L0-00	. SEAT, SPRING UPPER	2	
18	4V5-23340-L0-33	. UNDER BRACKET	1	YAMAHA BLACK
19	3R4-23191-M0-00	. BOOT, FRONT FORK	2	
20	1W4-23192-L0-00	. BAND	2	
21	1W4-23489-L0-00	. BAND	2	
22	1W4-23111-L1-00	. BOLT, CAP	2	
23	1W1-23185-L0-00	. COVER, VALVE	2	
24	509-23190-L0-00	. AIR VALVE	2	
25	3R4-23389-00-00	. GUIDE, CABLE	1	
26	4V2-23167-L0-00	. HOLDER, AXLE	1	
27	509-23163-L0-00	. O-RING	2	

CONTINUED ON NEXT FRAME ►

FRONT FORK

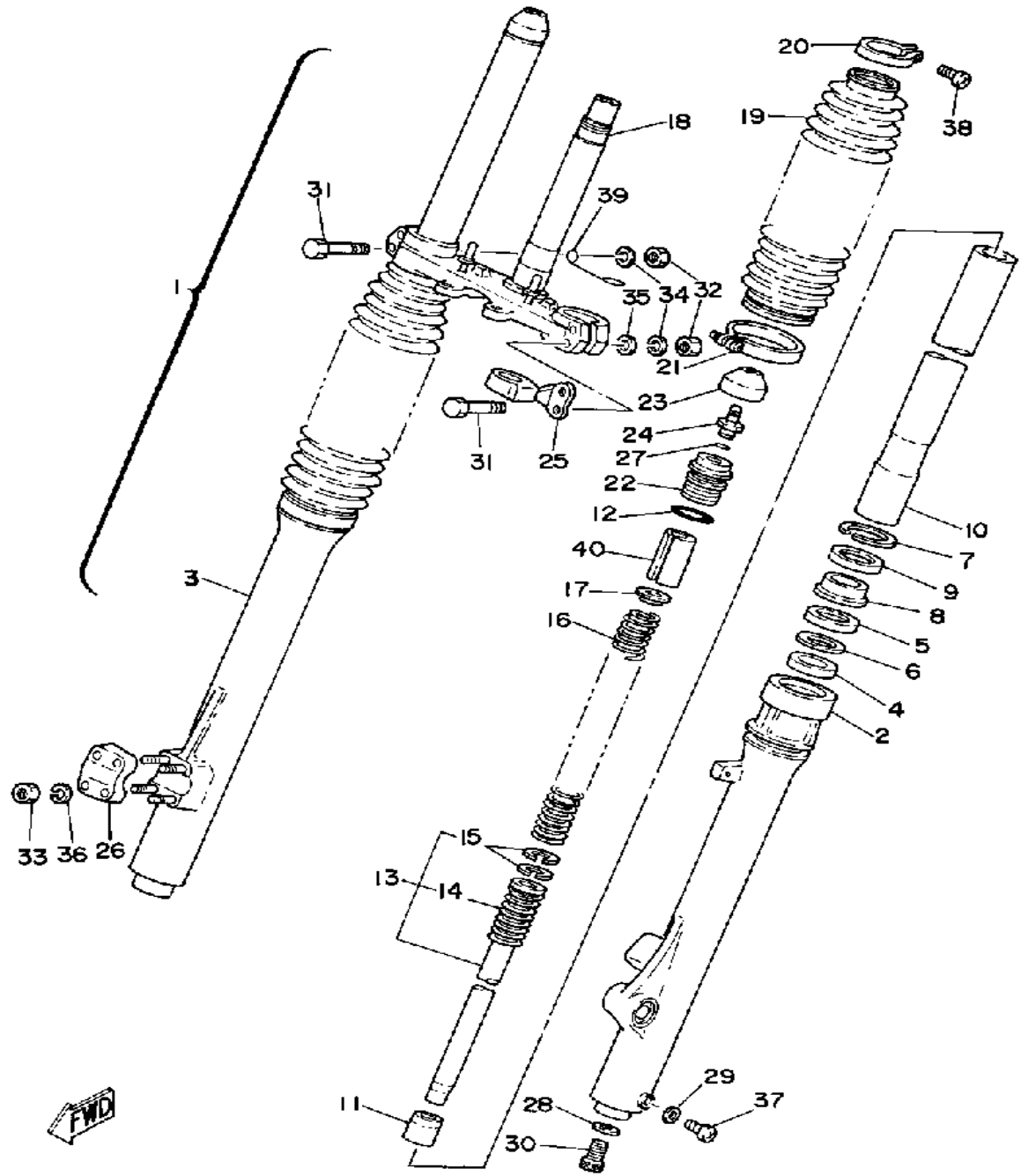

Ref. No.	Part Number	Description	Qty	Remarks
28	509-23158-L0-00	. GASKET	2	
29	122-23129-00-00	. GASKET, DRAIN PLUG	2	
30	3R4-23181-L0-00	. BOLT, HEX SCKT HEADSOCKET HEAD	2	
31	90101-08340-00	. BOLT	4	
32	95333-08600-00	. NUT	4	
33	95311-06600-00	. NUT	4	
34	92990-08100-00	. WASHER	4	
35	92901-08600-00	. WASHER	3	
36	92995-06100-00	. WASHER, SPRING	4	
37	4H7-23119-00-00	. PLUG, DRAIN - (122-23119-01)	2	
38	98506-04020-00	. SCREW, PAN HEAD	2	
39	4V5-23389-00-00	. GUIDE, CABLE	1	
40	(1W4-23118-L0-00)	SPACER	2	

FUEL TANK

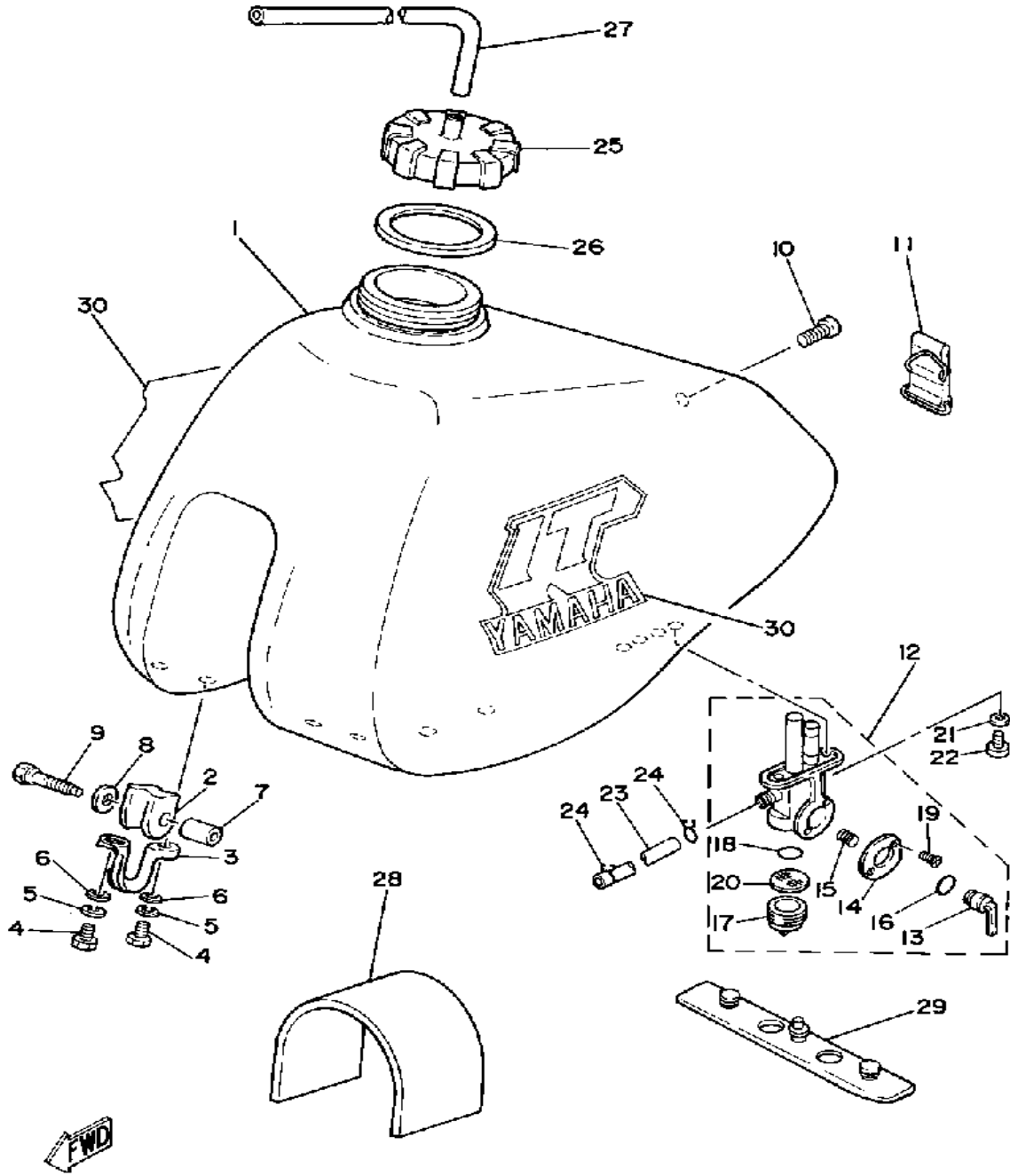

Ref. No.	Part Number	Description	Qty	Remarks
1	4V5-24110-00-00	FUEL TANK	1	
2	1W1-24182-01-00	DAMPER, LOCATING 2	2	
3	1W1-24144-01-00	HOLDER, DAMPER	2	
4	97013-06012-00	BOLT	4	
5	92995-06100-00	WASHER, SPRING	4	
6	92901-06600-00	WASHER	4	
7	90387-07393-00	COLLAR (308-84557-00)	2	
8	90201-06407-00	WASHER, PLATE (90201-06747-00)	2	
9	90119-06022-00	BOLT, WITH WASHER	2	
10	98903-06018-00	SCREW, BIND	1	
11	59V-24173-00-00	BAND, TANK FITTING 1	1	
12	4V5-24500-00-00	FUEL COCK ASSEMBLY 1	1	
13	(4V5-24524-00-00)	LEVER, COCK	1	
14	4V5-24525-00-00	. PLATE, LVR FITTING	1	
15	(357-24529-10-00)	SPRING	1	
16	4X8-24534-00-00	. SEAL, COCK	1	
17	4X8-24521-00-00	. CUP, FILTER	1	
18	4X8-24565-00-00	. GASKET	1	
19	4X8-24535-00-00	. SCREW, LVR FITTING	2	
20	4X8-24515-01-00	. NET, FILTER 2	1	
21	90202-05187-00	WASHER, PLATE	2	
22	90149-06011-00	SCREW	2	
23	90445-11152-00	HOSE	1	
24	90467-10008-00	CLIP	2	
25	1K7-24611-01-00	BODY, CAP	1	
26	1K7-24612-02-00	GASKET, CAP	1	
27	90445-09361-00	HOSE	1	
28	1W1-24183-00-00	DAMPER, LOCATING 3	1	

CONTINUED ON NEXT FRAME ►

FUEL TANK

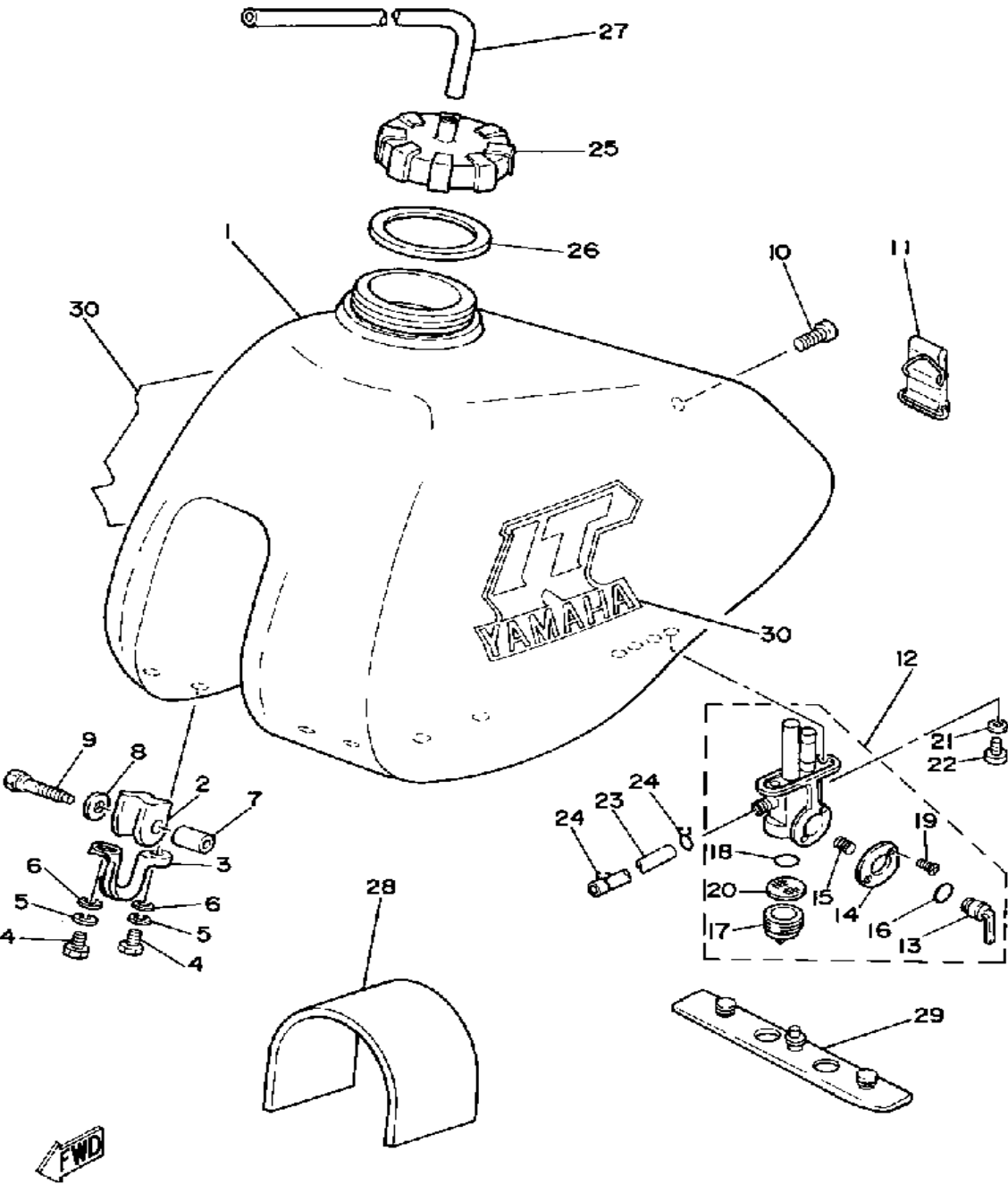

Ref. No.	Part Number	Description	Qty	Remarks
29	3R4-24181-00-00	DAMPER, LOCATING 1	1	
30	(3R9-24161-19-00)	EMBLEM 1	2	

SEAT

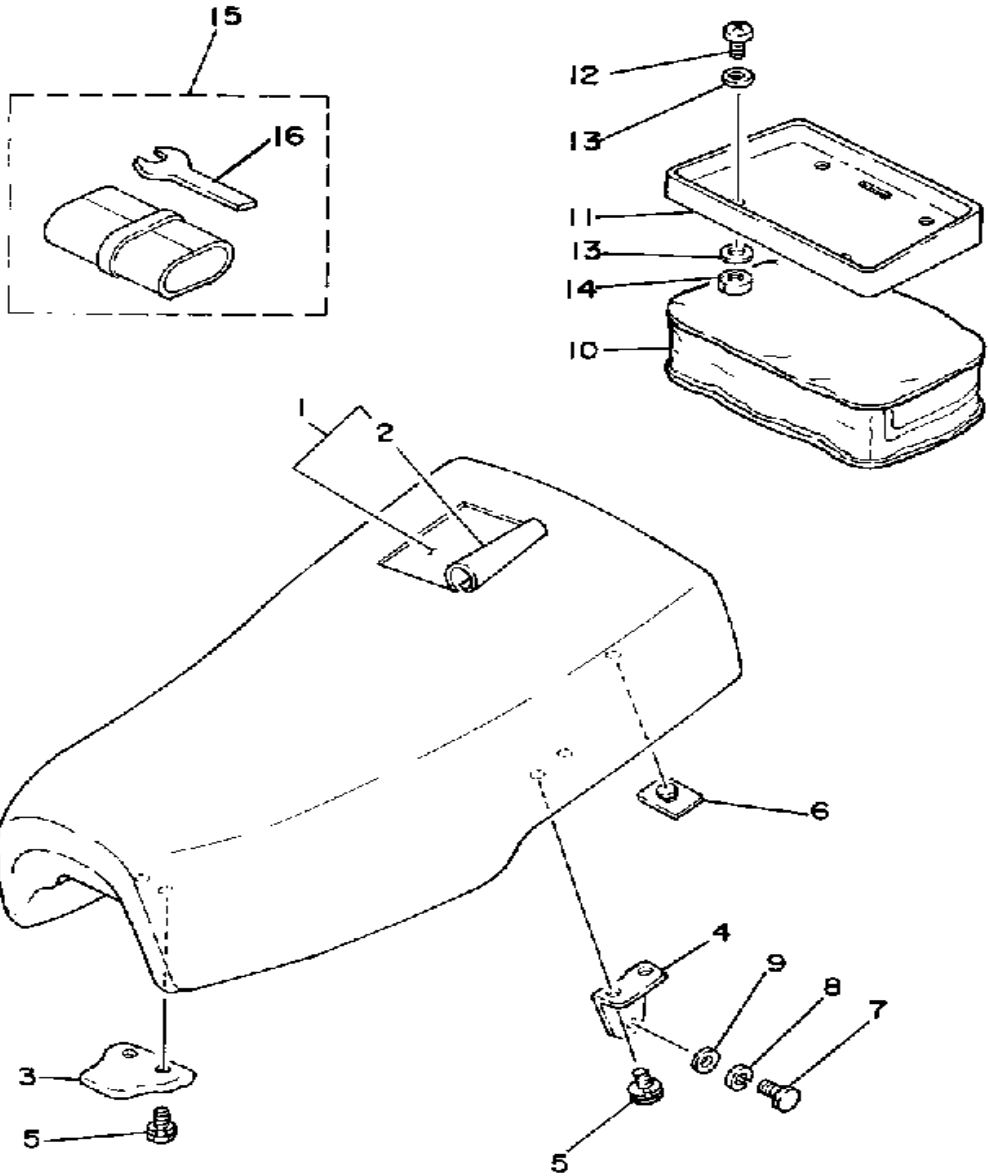

Ref. No.	Part Number	Description	Qty	Remarks
1	(4V5-W2473-10-00)	SEMI-DBL-SEAT ASSEMBLY ..	1	
2	4V5-24771-10-00	. COVER, SM-DBL SEAT (4V5-24771-00)	1	
3	1M1-24748-00-00	BRACKET, SEAT	1	
4	1W1-24738-00-00	BRACKET, SEAT	2	
5	90101-06304-00	BOLT	6	
6	509-24724-00-00	DAMPER, SEAT	2	
7	97313-06016-00	BOLT, HEXAGON	2	
8	92995-06100-00	WASHER, SPRING	2	
9	92901-06600-00	WASHER	2	
10	4V5-24850-00-00	CARRIER BOX ASSEMBLY ...	1	
11	4V5-24833-00-00	BRACKET, CARRIER 2	1	
12	98580-06020-00	SCREW	4	
13	90201-06067-00	WASHER, PLATE	8	
14	95601-06100-00	NUT, U	4	
15	1W2-W2810-00-00	TOOL KIT	1	
16	10V-28135-00-00	. SPANNER, SPECIAL	1	



FRONT WHEEL

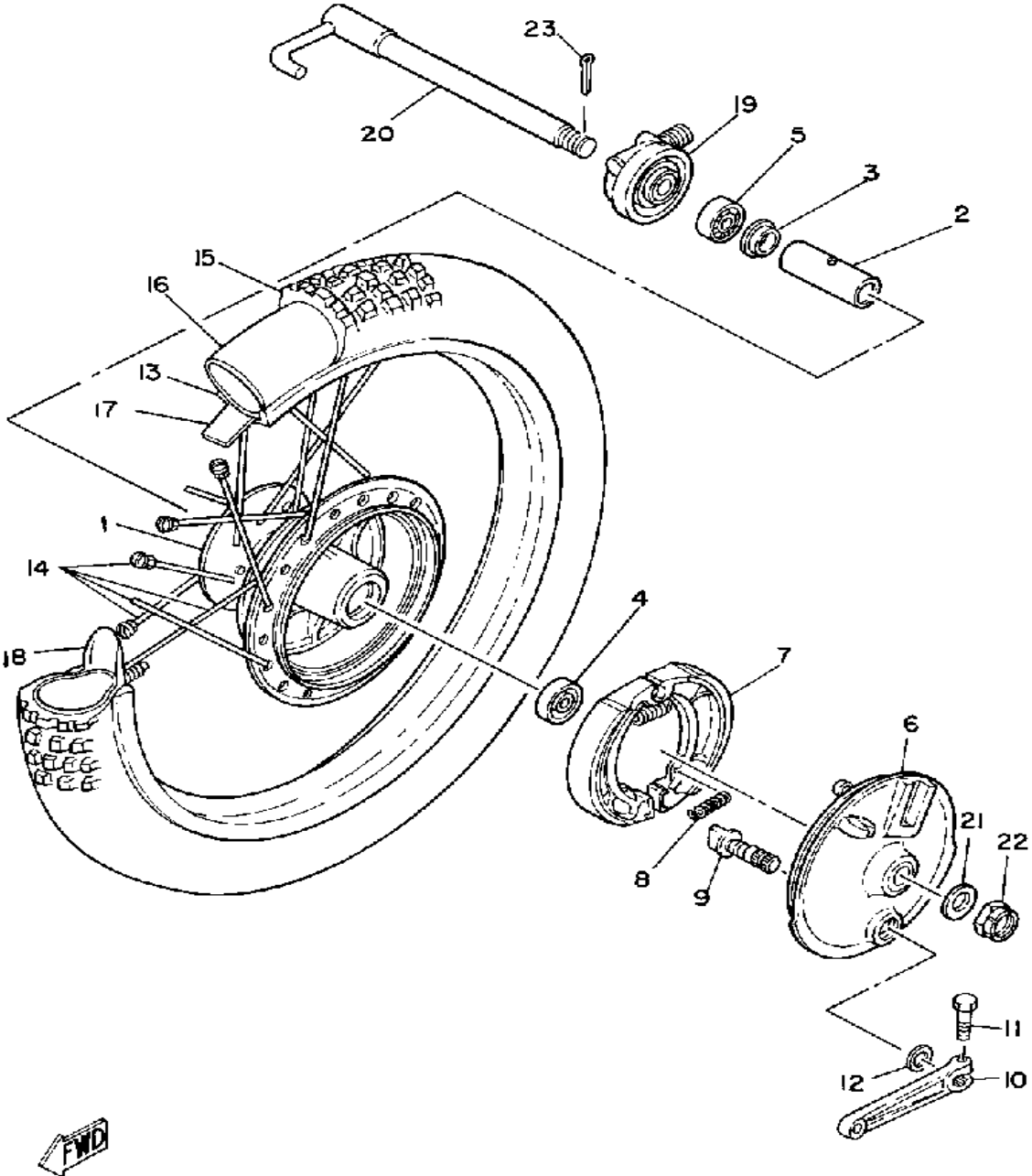

Ref. No.	Part Number	Description	Qty	Remarks
1	1K7-25111-10-98	HUB, FRONT	1	LOW GLOSS BLK
2	90560-15116-00	SPACER	1	
3	146-25116-00-00	FLANGE, SPACER 2	1	
4	93306-20226-00	BEARING	1	
5	93306-20209-00	BEARING (B6202)	1	
6	1W1-25016-11-98	BRAKE SHOE PLT ASSEMBLY (1W1-25121-02-98)	1	LOW GLOSS BLK
7	322-W2535-00-00	BRAKESHOE SET-2PCS	2	
8	90506-17328-00	SPRING, TENSION	2	
9	24X-25151-00-00	CAMSHAFT	1	
10	322-25155-00-00	LEVER, CAMSHAFT 1	1	
11	90101-06291-00	BOLT	1	
12	137-25159-00-00	SEAL, CAMSHAFT	1	
13	94416-21234-00	RIM 1.60X 1	1	
14	2W6-25104-02-00	SPOKE SET, FRONT	1	
15	(94130-21654-00)	300-21 MARK 2 (TT)	1	
16	94230-21126-00	TUBE (3.00-21)	1	
17	(94330-21088-00)	BAND, RIM	1	
18	5X2-25394-00-00	SPACER, BEAD	1	
19	1W2-25190-00-00	GEAR UNIT ASSEMBLY	1	
20	(99999-01618-00)	AXLE, WHEEL	1	
21	90201-15785-00	WASHER, PLATE	1	
22	90171-14020-00	NUT, CASTLE	1	
23	91401-30030-00	PIN, COTTER	1	

REAR WHEEL

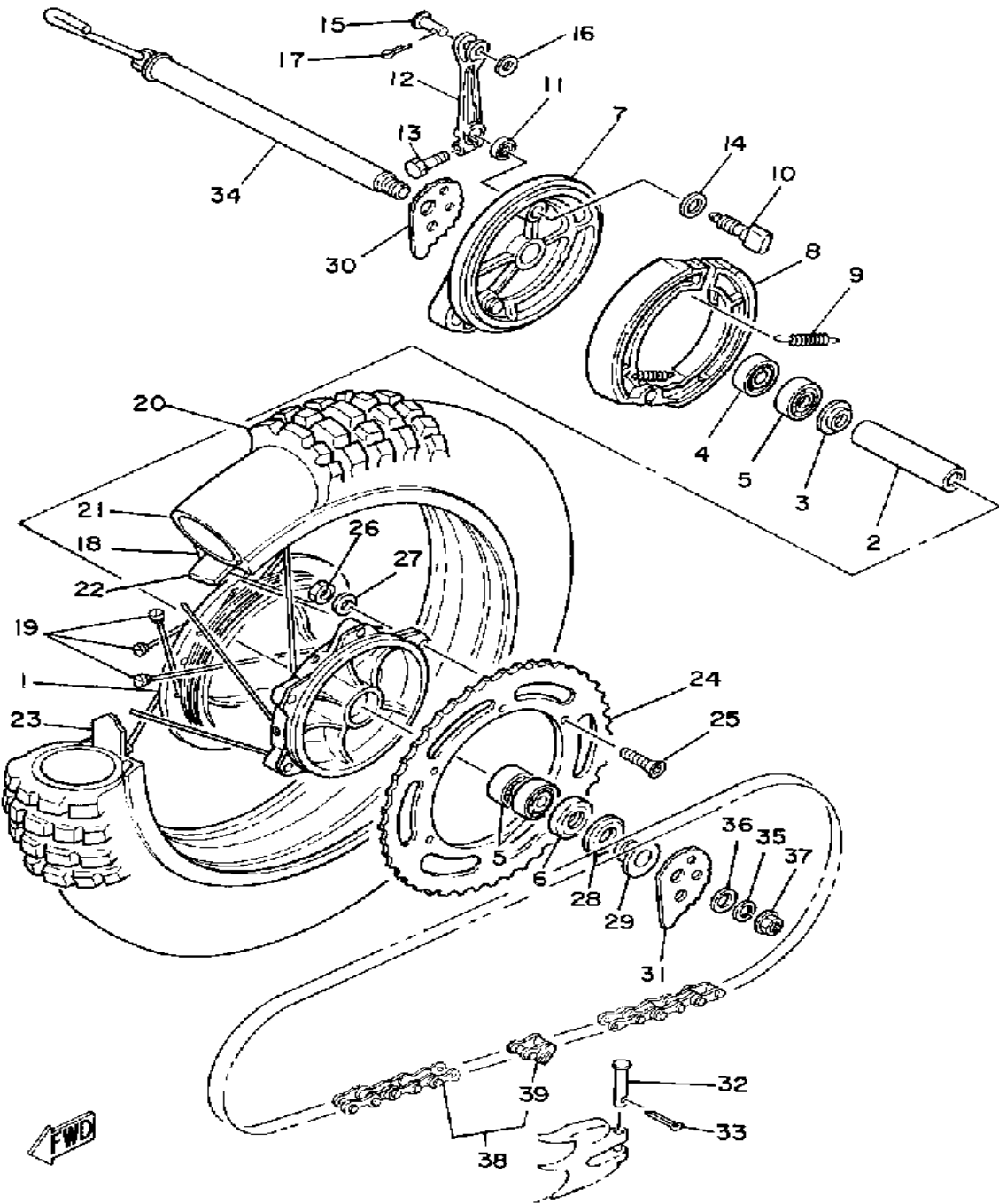

Ref. No.	Part Number	Description	Qty	Remarks
1	4V4-25311-00-98	HUB, REAR	1	
2	90560-20226-00	SPACER	1	
3	4V4-25315-00-00	FLANGE, SPACER	1	
4	93306-00418-00	BEARING	1	
5	93306-00406-00	BEARING (B6004Z)	3	
6	93102-28022-00	OIL SEAL	1	
7	4V5-25321-01-98	PLATE, BRAKE SHOE	1	
8	40T-W2536-00-00	BRAKESHOE SET-2PCS	2	
9	90507-20002-00	SPRING, TENSION	2	
10	5L4-25351-00-00	CAMSHAFT	1	
11	148-25359-00-00	SEAL, CAMSHAFT	1	
12	4V5-25355-00-00	LEVER, CAMSHAFT (168-25355-00)	1	
13	90101-06291-00	BOLT	1	
14	148-25353-00-00	SHIM, CAMSHAFT	1	
15	1W2-27237-00-00	PIN, CLEVIS	1	
16	90201-12631-00	WASHER, PLATE	1	
17	91401-25030-00	PIN, COTTER	1	
18	94425-18358-00	RIM 2.50X 8	1	
19	4V4-25304-00-00	SPOKE SET, REARALT. PART	1	
20	94115-186A2-00	150/80-18 M2A (TT) (94151-18684) (4.50-18-4PR)	1	
21	94245-18125-00	TUBE (4.50-18)	1	
22	94345-18081-00	BAND, RIM (4.50-18)	1	
23	2X5-25394-00-00	SPACER, BEAD	2	
24	26A-25446-50-33	SPROCKET, DRIVEN (46T) (26A-25446-50-00)	1	
	26A-25448-50-00	SPROCKET, DRIVEN (48T)	1	
	26A-25450-50-00	SPROCKET, DRIVEN (50T)	1	
	26A-25452-50-00	SPROCKET, DRIVEN (52T)	1	

CONTINUED ON NEXT FRAME ►

REAR WHEEL

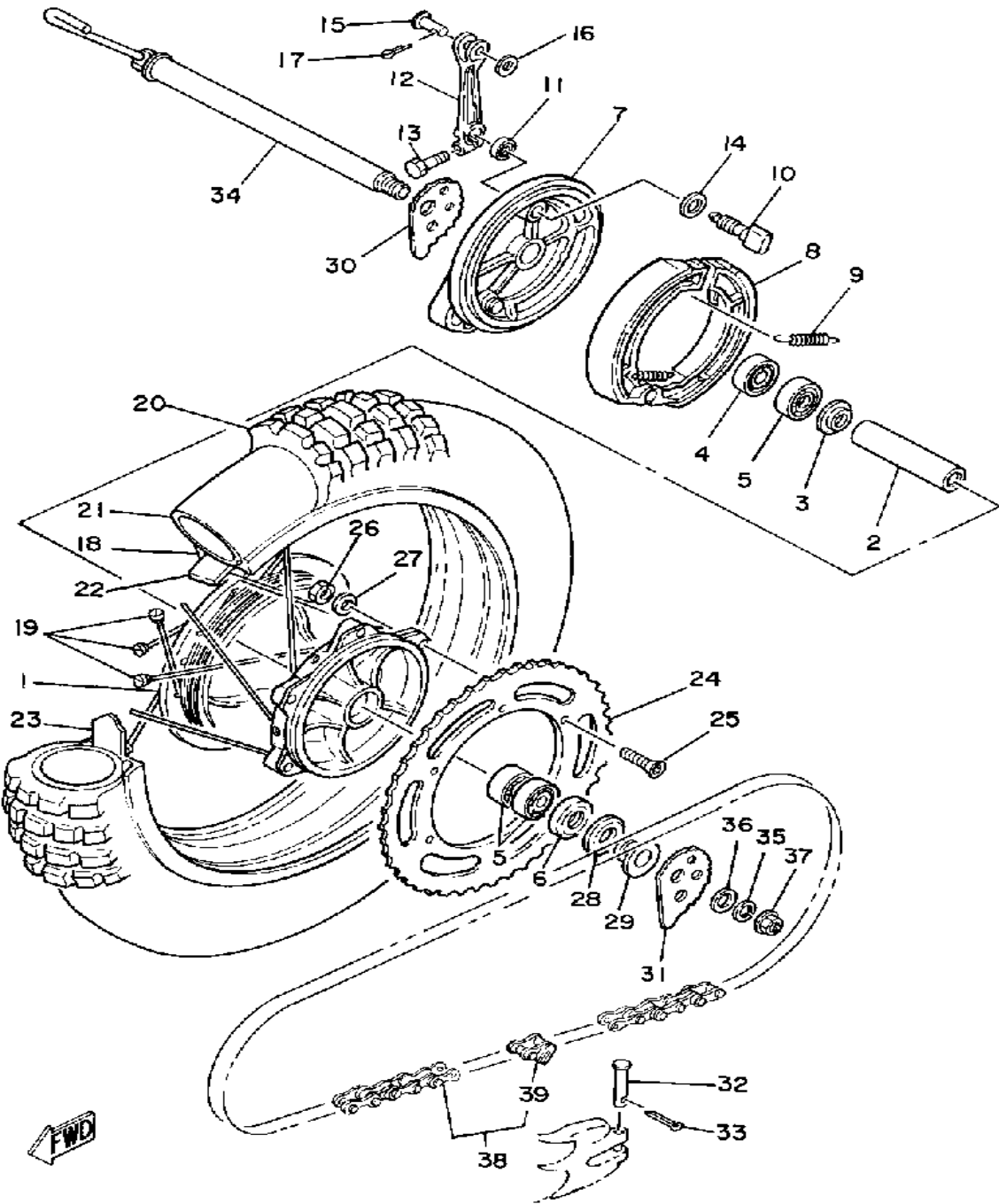

Ref. No.	Part Number	Description	Qty	Remarks
25	90110-08038-00	BOLT, HEX SKT HEAD	6	
26	90185-08089-00	NUT, SELF-LOCKING	6	
27	90201-081A6-00	WASHER, PLATE	6	
28	4V4-25367-00-00	COVER, HUB DUST	1	
29	90387-201E6-00	COLLAR	1	
30	4V5-25389-00-00	PULLER, CHAIN 2	1	
31	4V5-25388-01-00	PULLER, CHAIN 1	1	
32	91701-05055-00	PIN, CLEVIS	2	
33	91490-16020-00	PIN, COTTER	2	
34	4V5-25381-00-00	AXLE, WHEEL	1	
35	92901-18100-00	WASHER, SPRING	1	
36	92901-20600-00	WASHER, WAVE	1	
37	90179-18332-00	NUT	1	
38	94585-20108-00	520 DS 108L (520DS-108L)	1	
39	94685-20001-00	. JOINT CHAIN	1	

HANDLEBAR - CABLE

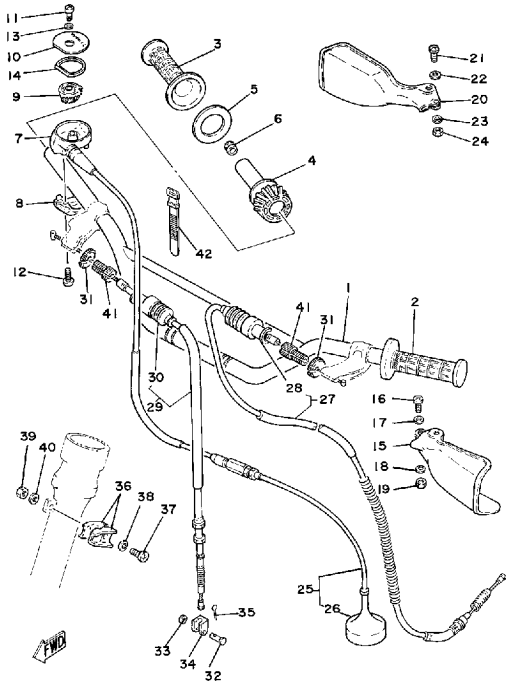

Ref. No.	Part Number	Description	Qty	Remarks
1	2A8-26111-00-00	HANDLEBAR	1	
2	4V4-26241-01-00	GRIP (L.H.) (4V4-26241-00) ...	1	
3	1LX-26242-01-00	GRIP (RIGHT)	1	
4	4V6-26243-00-00	TUBE, THRTL GUIDE	1	
5	4V4-26249-00-00	RING, LEAF	1	
6	90338-12192-00	PLUG	1	
7	4V4-26281-00-00	CAP, GRIP UPPER	1	
8	4V4-26282-00-00	CAP, GRIP LOWER	1	
9	4V6-2628E-00-00	GEAR, BEVEL	1	
10	4V4-2628F-09-00	CAP, GEAR (4V4-2628F-00) ...	1	
11	98906-05010-00	SCREW, BIND	1	
12	98580-05016-00	SCREW, PAN HEAD	2	
13	90430-05009-00	GASKET	1	
14	4V4-2628G-00-00	PACKING	1	
15	3Y0-26141-00-00	GUARD, BRUSH 1	1	WHITE
16	98503-06014-00	SCREW, PAN HEAD (92502-06016)	1	
17	92901-06600-00	WASHER	1	
18	92990-06200-00	WASHER	1	
19	95380-06700-00	NUT	1	
20	3Y0-26142-00-00	GUARD, BRUSH 2	1	WHITE
21	98503-06014-00	SCREW, PAN HEAD (92502-06016)	1	
22	92901-06600-00	WASHER	1	
23	92990-06200-00	WASHER	1	
24	95380-06700-00	NUT	1	
25	4V4-26311-00-00	CABLE, THROTTLE 1	1	
26	510-26329-00-00	. CAP, RUBBER	1	
27	4V5-26335-01-00	CABLE, CLUTCH	1	

CONTINUED ON NEXT FRAME ►

HANDLEBAR - CABLE

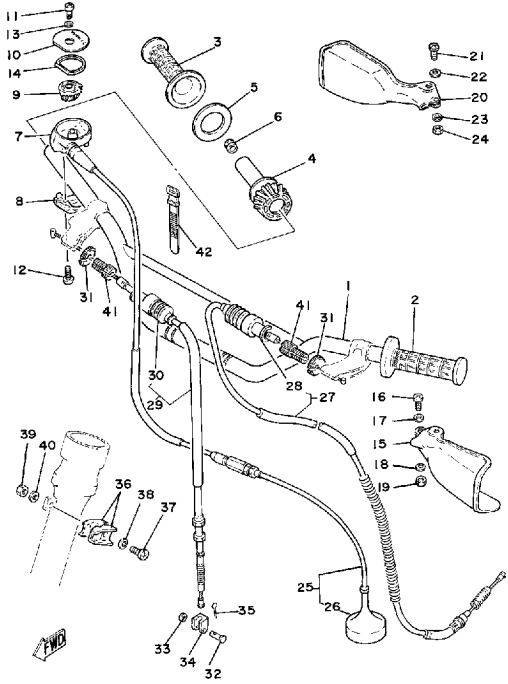

Ref. No.	Part Number	Description	Qty	Remarks
28	1E6-26342-00-00	. BOOT, CABLE	1	
29	4V5-26341-00-00	CABLE, BRAKE	1	
30	1E6-26342-00-00	. BOOT, CABLE	1	
31	90179-08148-00	NUT	2	
32	90240-08013-00	PIN, CLEVIS	1	
33	90201-08083-00	WASHER, PLATE	1	
34	156-26347-00-00	JOINT, CABLE	1	
35	91490-20020-00	PIN, COTTER	1	
36	90462-14055-00	CLAMP	2	
37	98511-06025-00	SCREW PAN HEAD (92501-06025)	1	
38	92995-06100-00	WASHER, SPRING	1	
39	95380-06600-00	NUT	1	
40	92901-06600-00	WASHER	1	
41	90123-08046-00	BOLT	2	
42	437-83936-11-00	BAND, SWITCH CORD	1	

STAND - FOOTREST

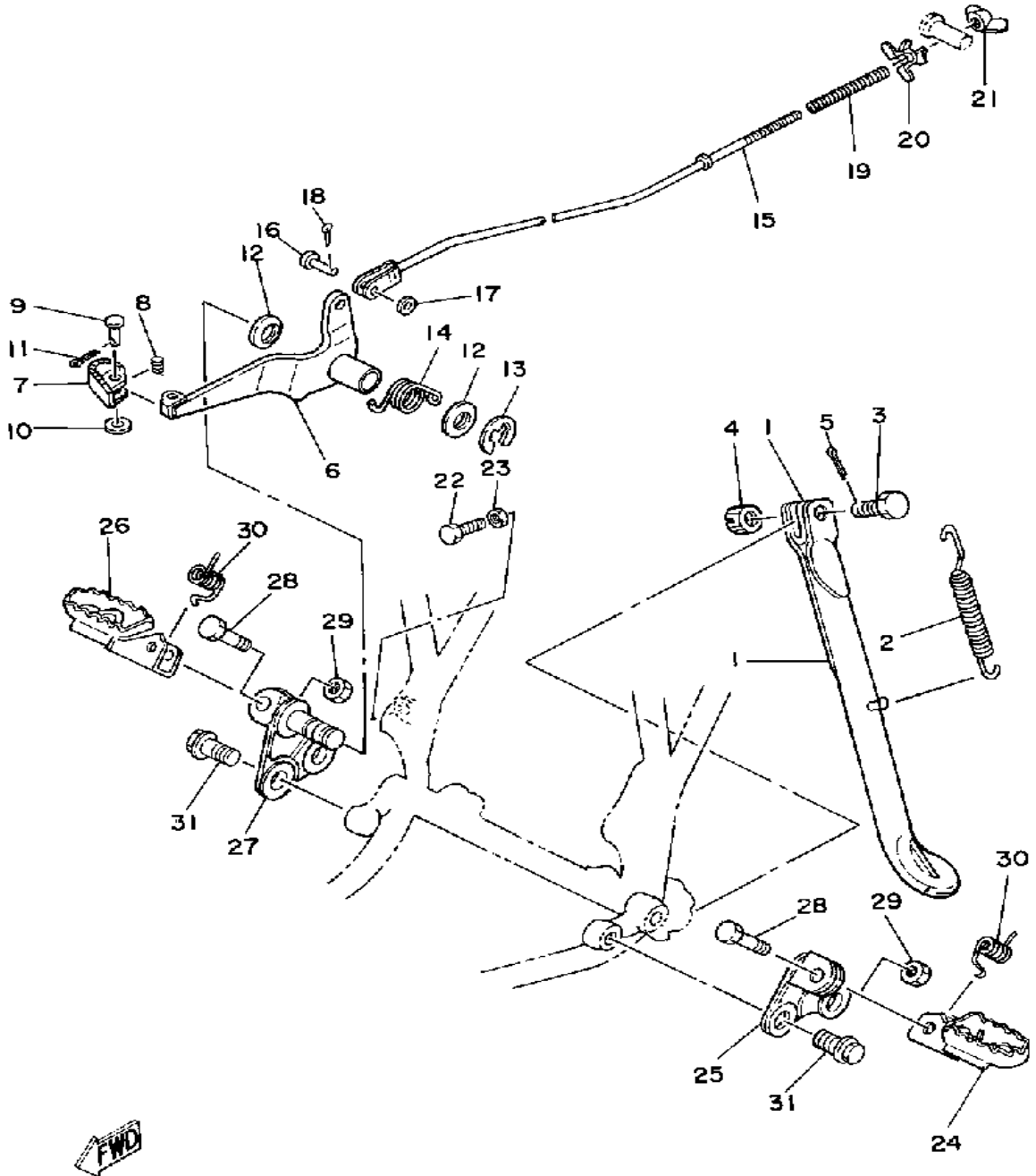

Ref. No.	Part Number	Description	Qty	Remarks
1	4V5-27311-01-33	STAND, SIDE	1	
2	90507-29008-00	SPRING, TENSION	1	
3	90102-10006-00	BOLT, WITH HOLE (278-27317-00)	1	
4	95303-10900-00	NUT, SLOTTED	1	
5	91490-20025-00	PIN, SPLIT	1	
6	4V5-27211-00-00	PEDAL, BRAKE	1	
7	3R8-27242-00-00	PEDAL, BRAKE	1	
8	90508-14429-00	SPRING, TORSION	1	
9	91701-06028-00	PIN, CLEVIS	1	
10	92901-06600-00	WASHER	1	
11	91490-20020-00	PIN, COTTER	1	
12	4V5-27286-00-00	COVER, DUST	2	
13	93430-10015-00	CIRCLIP, E-TYPE	1	
14	90508-32478-00	SPRING, TORSION	1	
15	2X4-27231-01-00	ROD, BRAKE	1	
16	90240-06103-00	PIN, CLEVIS	1	
17	92990-06200-00	WASHER	1	
18	91490-20020-00	PIN, COTTER	1	
19	90501-10245-00	SPRING, COMPRESSION	1	
20	1W2-27239-00-00	SEAT, SPRING	1	
21	90179-06411-00	NUT	1	
22	97011-06020-00	BOLT	1	
23	95380-06700-00	NUT	1	
24	5X3-27411-00-00	FOOTREST 1 (250H)	1	
25	4V5-27412-00-00	BRACKET, FOOTREST 1	1	
26	5X3-27411-00-00	FOOTREST 1 (250H)	1	
27	4V5-27422-00-00	BRACKET, FOOTREST 2	1	
28	90101-08428-00	BOLT	2	

CONTINUED ON NEXT FRAME ►

STAND - FOOTREST

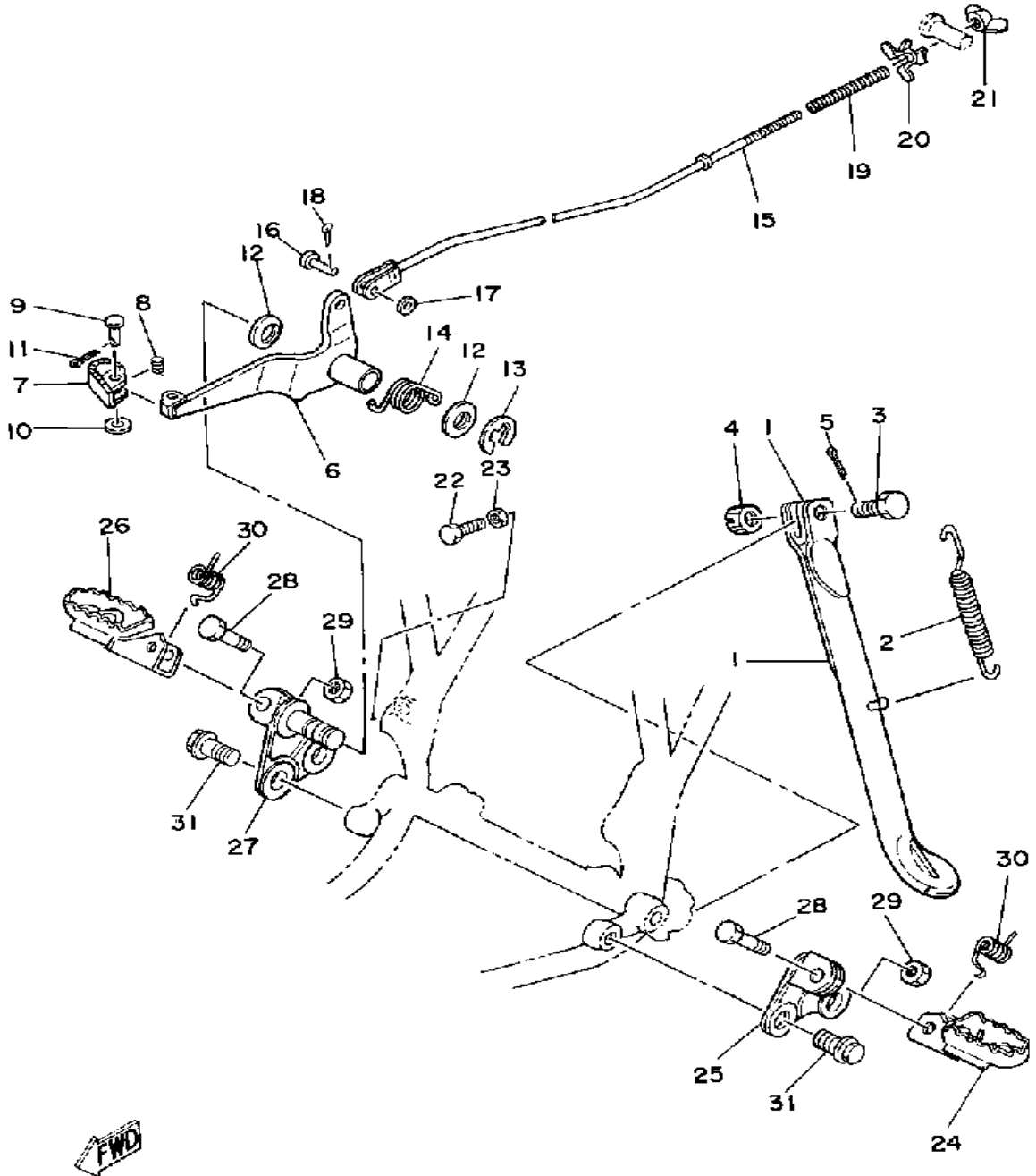

Ref. No.	Part Number	Description	Qty	Remarks
29	95611-08100-00	NUT, U	2	
30	90508-20023-00	SPRING, TORSION	2	
31	90105-12096-00	BOLT, WASHER BASED	4	

METER

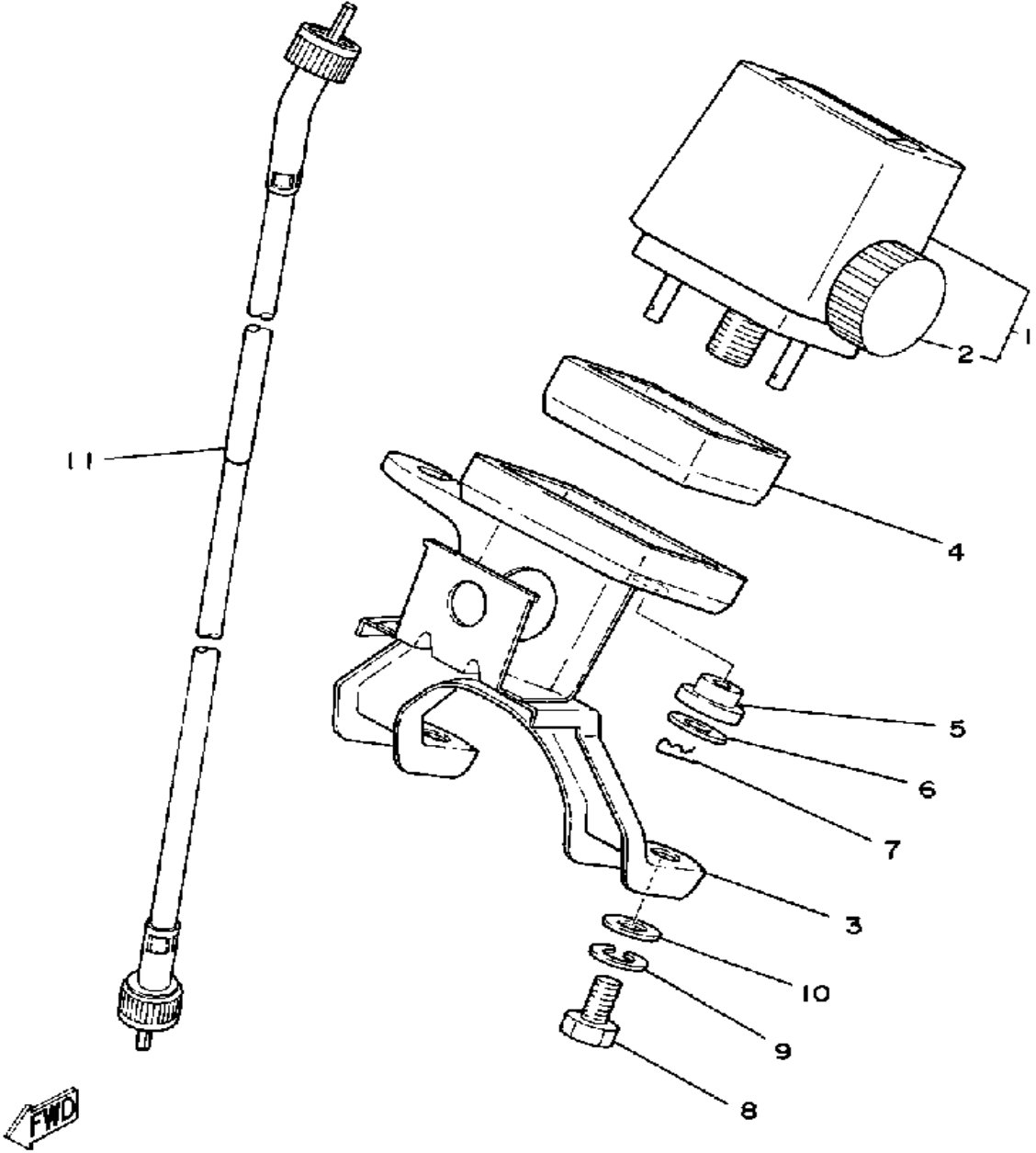

Ref. No.	Part Number	Description	Qty	Remarks
1	4V5-83505-60-00	TRIP METER CMPLT	1	
2	4V5-83578-00-00	. KNOB, TRIP METER	1	
3	4V5-83519-00-00	BRACKET, METER	1	
4	4V5-83513-00-00	DAMPER	1	
5	1M1-83526-00-00	DAMPER 2	2	
6	90201-052E2-00	WASHER, PLATE	2	
7	90468-10050-00	CLIP	2	
8	97013-06012-00	BOLT	2	
9	92995-06100-00	WASHER, SPRING	2	
10	92901-06600-00	WASHER	2	
11	4V5-83550-01-00	SPEEDOMETER CABLE	1	

HEADLIGHT

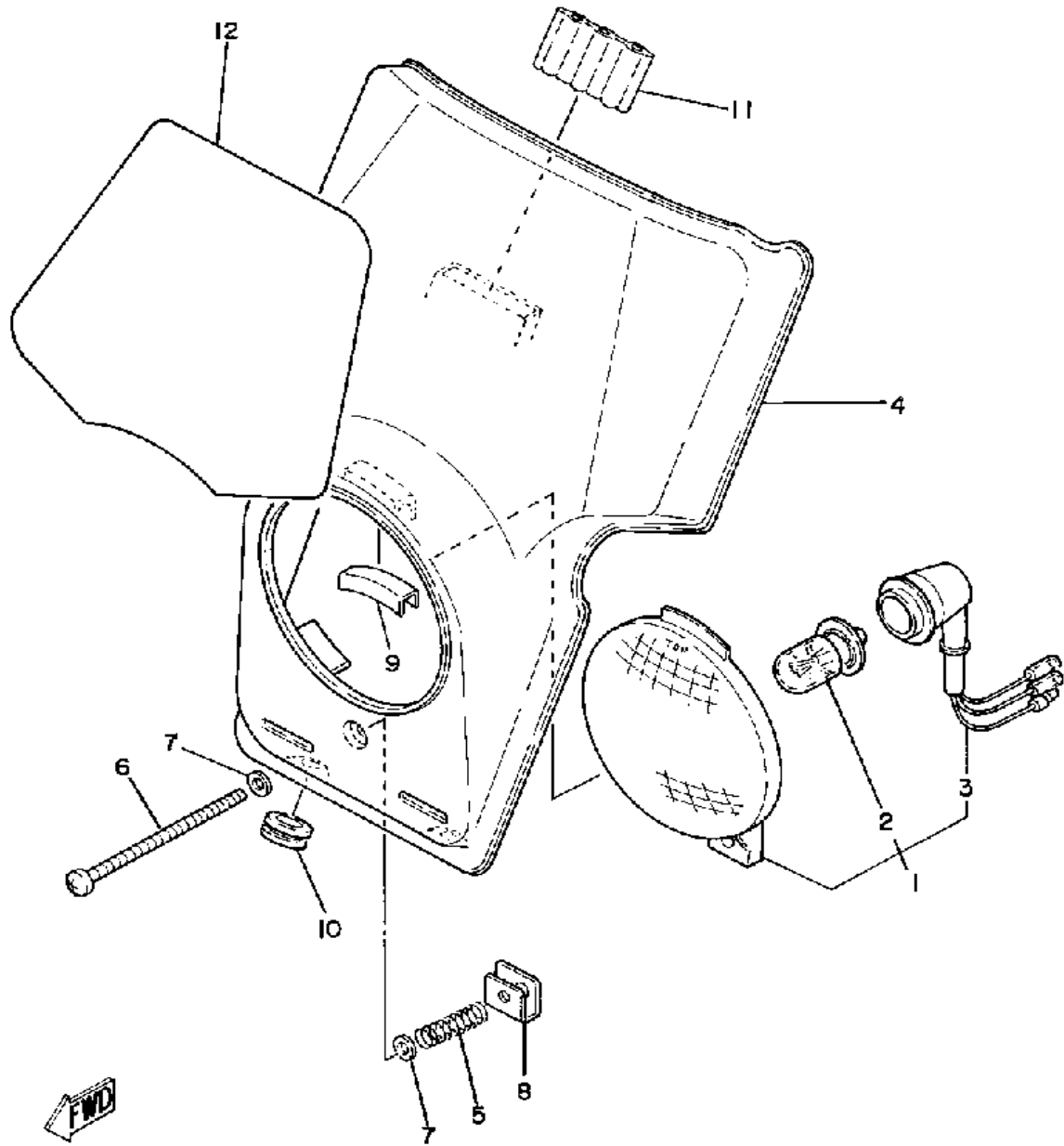

Ref. No.	Part Number	Description	Qty	Remarks
1	4V5-84110-00-00	HEADLIGHT UNIT ASSEMBLY	1	
2	527-84114-09-XX	. BULB, HL 6V25/25W	1	
3	4V5-84140-00-00	. SOCKET CORD ASSEMBLY	1	
4	(4V5-84130-00-00)	BODY ASSEMBLY, HEADLIGHT	1	CLEAN WHITE
5	4V5-84132-00-00	SPRING, SCREW	1	
6	849-84724-00-00	SCREW, LENS FITTING	1	
7	92901-04600-00	WASHER, PLATE	2	
8	4V5-84134-00-00	NUT, ADJUST	1	
9	(4V5-84143-00-00)	DAMPER, HDLT STAY	1	
10	90480-12053-00	GROMMET	2	
11	4V5-83592-00-00	DAMPER	1	
12	4V5-84141-00-00	EMBLEM, HEADLIGHT	1	

TAILLIGHT

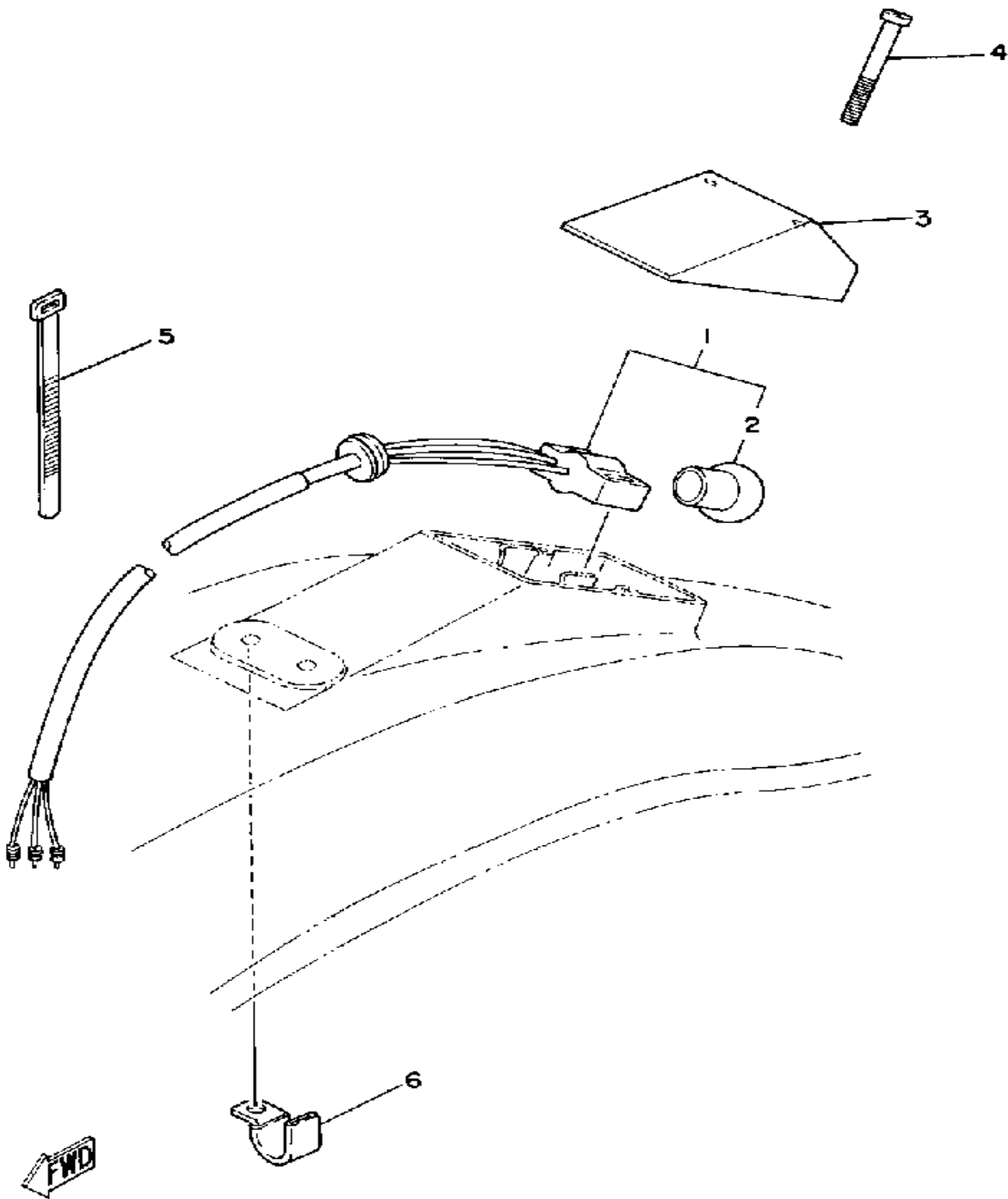

Ref. No.	Part Number	Description	Qty	Remarks
1	4V5-84536-00-00	SOCKET CORD ASSEMBLY ..	1	
2	122-84514-30-00	. BULB	1	
3	4V5-84521-00-00	LENS, TAILLIGHT	1	
4	1M1-84524-60-00	SCREW, LENS FITTING	2	
5	437-83936-01-00	BAND, SWITCH CORD	2	
6	90462-05005-00	CLAMP	1	

ELECTRICAL 1

Ref. No.	Part Number	Description	Qty	Remarks
1	5G4-82310-40-00	IGNITION COIL ASSEMBLY (J17-82310-21)	1	
2	98511-06025-00	SCREW PAN HEAD (92501-06025)	2	
3	92995-06100-00	WASHER, SPRING	2	
4	90462-05005-00	CLAMP	1	
5	81E-82370-20-00	PLUG CAP ASSEMBLY	1	
	8E7-82370-11-00	PLUG CAP ASSEMBLY	1	WITH NOISE SUPPRESSOR
6	4V5-82590-00-00	WIRE HARNESS ASSEMBLY	1	
7	437-83936-01-00	BAND, SWITCH CORD	4	
8	25G-83936-01-00	BAND, SWITCH CORD	1	

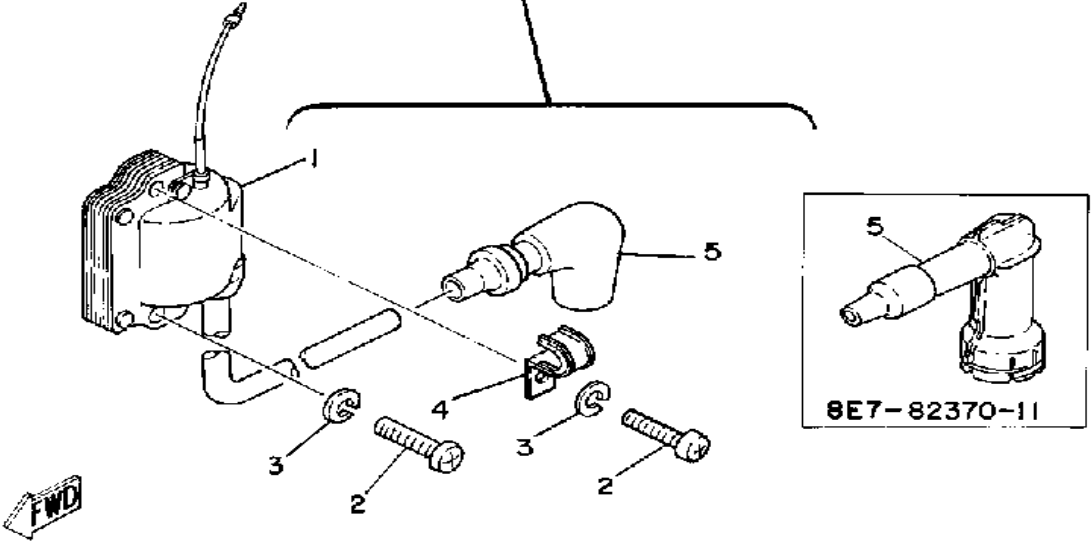
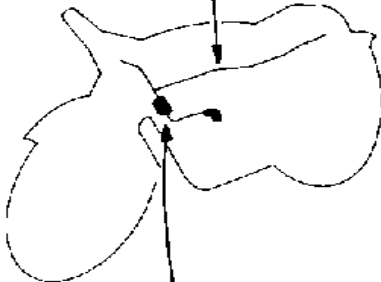
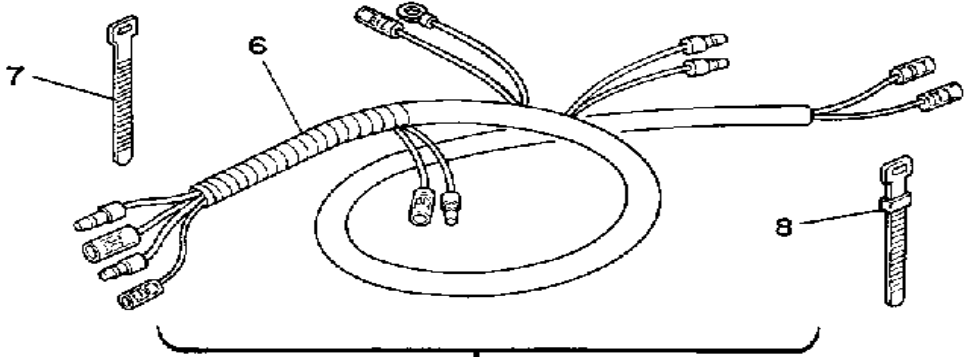

HANDLE SWITCH - LEVER

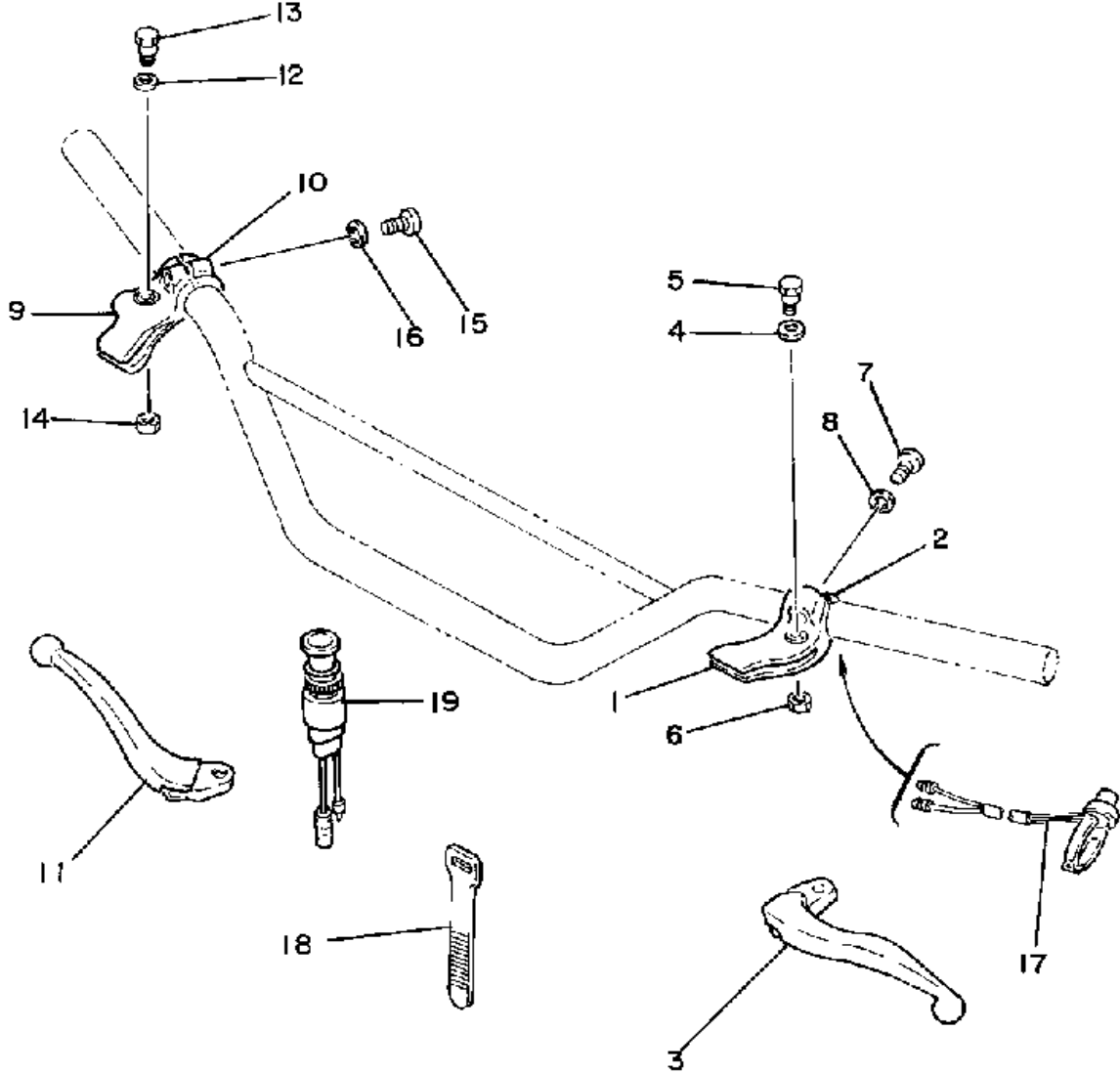

Ref. No.	Part Number	Description	Qty	Remarks
1	5F6-82911-00-00	HOLDER, LEVER 1	1	
2	4V4-82913-00-00	HOLDER, LEVER LOWER 1	1	
3	23X-83912-00-00	LEVER 1	1	
4	90201-08083-00	WASHER, PLATE	1	
5	90109-06797-00	BOLT	1	
6	95601-06100-00	NUT, U	1	
7	98506-05020-00	SCREW, PAN HEAD	2	
8	92906-05100-00	WASHER, SPRING	2	
9	38V-82921-00-00	HOLDER, LEVER 2	1	
10	4V4-82913-00-00	HOLDER, LEVER LOWER 1	1	
11	23X-83922-00-00	LEVER 2	1	
12	90201-08083-00	WASHER, PLATE	1	
13	90109-06797-00	BOLT	1	
14	95601-06100-00	NUT, U	1	
15	98506-05020-00	SCREW, PAN HEAD	2	
16	92906-05100-00	WASHER, SPRING	2	
17	23X-83976-00-00	SWITCH, HANDLE 1	1	
18	437-83936-01-00	BAND, SWITCH CORD	2	
19	4V5-82520-00-00	LIGHT SWITCH ASSEMBLY	1	



IT250H 1981 SERVICE DATA

MODEL - IBM I.D. NUMBER	IT250H	4V5
Initial Engine Number / Frame Number	4V5-000101 / 4V5-000101	
Basic Color(s)	White	
Fuel Type / Fuel Tank Capacity / Reserve Capacity	Premium / 13 Lit. (3.4 Gal.) / ∅	
Dry Vehicle Weight	106 kg (233 lb)	
ENGINE TYPE	2-Stroke, Air-Cooled, Reed Valve	
Bore/Stroke/Number Cylinders/Displacement (cc)	70mm / 64mm / 1 / 246cc	
Compression Ratio/Compression Pressure Min~Max	7.8:1 / NA	
Piston Skirt Clearance New / Max	0.045 ~ 0.050mm / 0.1mm	
Ring End Gap Top / 2nd / 3rd	0.3 ~ 0.5mm / 0.3 ~ 0.5mm / ∅	
Valve Clearance (Cold) Intake / Exhaust	∅	
Oil Pressure Hot / rpm	∅	
Oiling System	Premix 16:1 Yamalube R*	
Capacity: Dry	∅	
Oil and Filter Change	∅	
Oil Change	∅	
Lubricant: Temp. Above 5°C (40°F)	Yamalube R*	
Temp. Below 15°C (60°F)	Yamalube R*	
AUTOLUBE - Min Stroke / Color Code	∅	
Minimum Output @ 200 Cycles	∅	
Maximum Output @ 200 Cycles	∅	
CARBURETOR - Mfr. / Type / I.D. Number	Mikuni / VM36SS / 4V5-00	
Main Jet / Pilot Jet	380 / 50	
Needle Jet / Jet Needle-Clip Position	N-8 / 6F34-3	
Slide Cutaway or Throttle Valve	2.0	
Float Level / Fuel Level	18.1 ± 1mm / 33.0 ± 1.0mm	
Idle rpm	∅	
Max CO* / Max HC* / Set CO	∅	
SUSPENSION		
Front Forks: Oil Type / Level / Qty	10 Wt. Fork Oil* / ∅ / 415cc	
Gas Pressure	0 kg/cm ²	
Spring Length Std	603mm	
Monoshock: Oil Type / Qty	Not Rebuildable	
Gas Pressure	15 kg/cm ² (213 psi)	
Minimum Brake Lining Thickness	Front: 2.0mm Rear: 2.0mm	
Tire Size (Nominal Pressure)	F:3.00-21 (psi Optional) R:5.10-18 (psi Optional)	
TRANSMISSION - Oil Type/Qty Chg/Qty Reassemble	SAE 10W30 SE / 750cc / 800cc	
Primary Drive Type / Teeth / Ratio	Helical Gear / 63-24 / 2.628	
Secondary Drive Type / Teeth / Chain	Chain / 50-14 / DK520DS-108L	
Clutch Friction Plate Thickness Std ~ Min	36.4mm ~ 35.4mm	
Clutch Spring Length Std ~ Min	34.8 ~ 33.8mm	
Middle Gear Case Capacity	∅	
Final Gear Case Capacity	∅	
Gear Case Lubricant: Temp. Above 5°C (40°F)	∅	
Temp. Below 15°C (60°F)	∅	
All Weather Conditions	∅	

SERVICE COPY	SER MGR	MECH	MECH	MECH	BINDER
OFFICE COPY	GEN MGR	SALES	PARTS	BINDER	PAGE 1 OF 2

CHARGING SYSTEM	Flywheel Magneto
Battery: Model / Specific Gravity / Charge Rate	∅
Maximum Output	∅
TROUBLESHOOTING	
Field Coil Color Code / Ω	∅
Charge Coil Color Code / Ω	∅
IGNITION SYSTEM	Capacitor-Discharge Ignition
Ignition Timing	1.65mm BTDC
Spark Plug Type	Champion N-2G
Spark Plug Gap / Torque / Cap Ω	0.6 ~ 0.7mm / 2.5 m·kg / 0K Ω
Point Gap / Condenser Capacitance	∅ / ∅
TROUBLESHOOTING	
Ignition Coil Test Gap / Primary Ω / Secondary Ω	6mm / 1.0 Ω ± 10% / 5.9K Ω ± 10%
Pulser Coil or Pickup Coil Color Code / Ω	Wht-Red ~ Blk / 9.0 Ω ± 10%
Source Coil Color Code / Ω	Lx: 8m ~ Gry / 360 Ω ± 10% Hx: Red ~ Blue / 14 Ω ± 10%
LIGHTING SYSTEM	
Headlight / Taillight / Signal Rating	6V25-25W / 6V5.3W / ∅
TROUBLESHOOTING	
Lighting Coil Color Code / Ω	Yel-Red ~ Blk / 0.48 Ω ± 10%
TORQUE VALUES	
Front Axle Nut	15 x 1.5: 5.8 m·kg
Front Axle Holder Nut	6 x 1.0: 1.0 m·kg
Rear Axle Nut	18 x 1.5: 10.0 m·kg
Rear Axle Pinch Bolt	∅
Clutch Nut	20 x 1.0: 7.5 m·kg
Drain Plug	14 x 1.25: 2.0 m·kg
Cylinder Head Cover	∅
Cylinder Head:	8 x 1.25: 2.5 m·kg
Engine Mounting Bolts: Front, Upper	8 x 1.25: 3.0 m·kg
Front, Lower	8 x 1.25: 3.0 m·kg
Rear, Upper	10 x 1.25: 6.5 m·kg
Stay, Front Nut	8 x 1.25: 3.0 m·kg
Bolt	8 x 1.25: 1.5 m·kg

∅ = Does Not Apply To This Model
NA = Information Not Available

*Available From Yamaha Parts Distributors Inc.
*For Diagnostic Use Only

