

YAMAHA

GENUINE

PARTS CATALOGUE

MOTORCYCLE

CYLINDER HEAD-CYLINDER

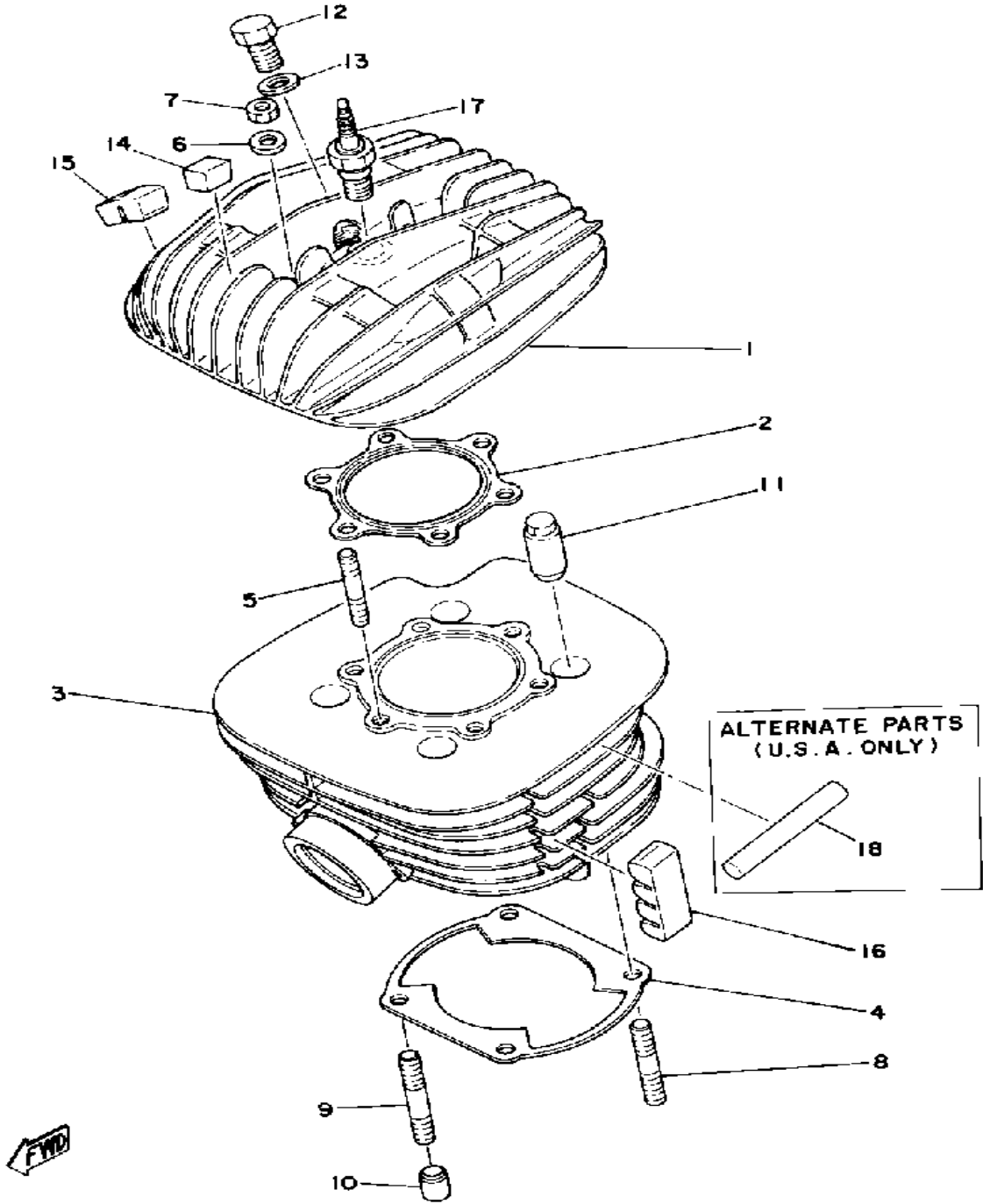

Ref. No.	Part Number	Description	Qty	Remarks
1	(2X8-11111-00-00)	HEAD, CYLINDER 1	1	
2	500-11181-00-00	GASKET, CYLINDER HEAD 1	1	
3	(2X5-11311-00-00)	CYLINDER 1	1	
4	2X5-11351-00-00	GASKET, CYLINDER	1	
5	90116-08321-00	BOLT, STUD	6	
6	90201-08100-00	WASHER, PLATE	6	
7	95333-08600-00	NUT	6	
8	90116-10263-00	BOLT, STUD	2	
9	90116-10258-00	BOLT, STUD	2	
10	99530-14016-00	PIN, DOWEL	2	
11	90179-10201-00	NUT	4	
12	90340-14022-00	PLUG, STRAIGHT SCRW (214-11197-00)	1	
13	214-11198-01-00	GASKET	1	
14	363-11161-00-00	ABSORBER 1 (363-11161-00)	2	
15	1W2-11161-00-00	ABSORBER 1	2	
16	2N6-11127-00-00	ABSORBER 3	2	
17	NGK-B8ES0-00-00	PLUG, SPARK (NGK B8ES)	1	CHAMPION
18	(1W6-11161-00-00) (2X5-W1160-00-00)	ABSORBER 1 O W KIT	10	ALTERNATE PART OPTIONAL PART

SPECIAL SERVICE TOOLS
90890-01135-00 CRANKCASE SEPARATOR

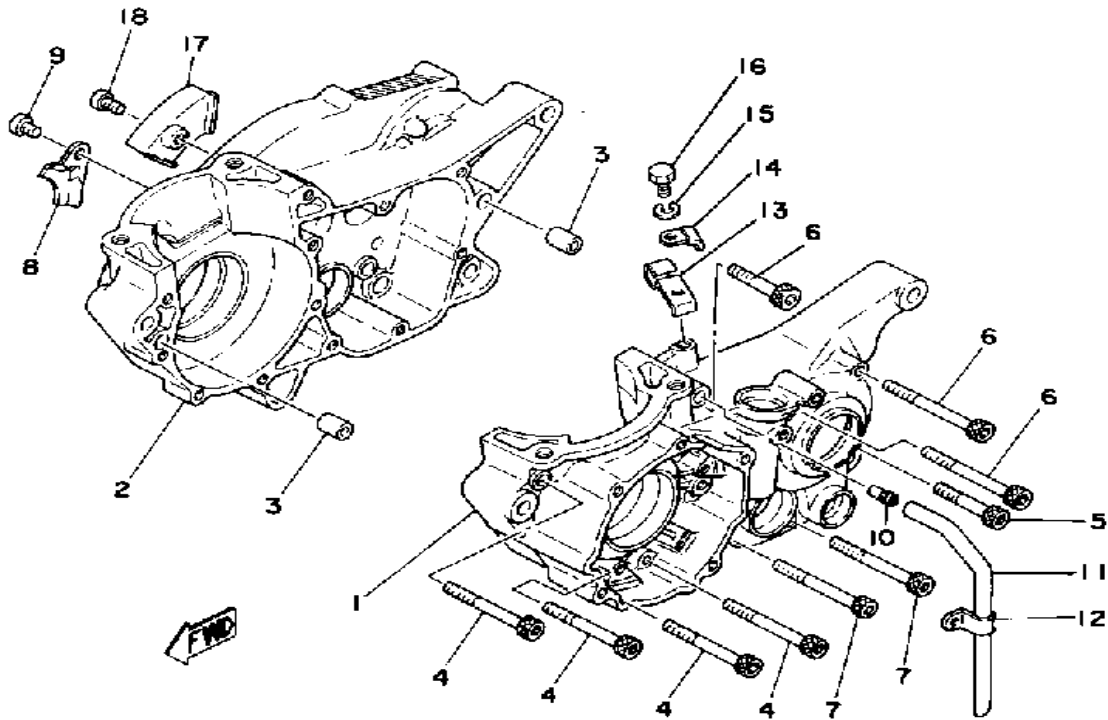
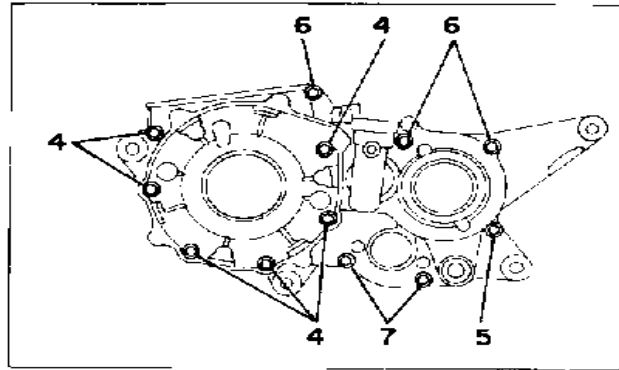

CRANKCASE

Ref. No.	Part Number	Description	Qty	Remarks
1	2X5-15111-00-00	CRANKCASE 1	1	
2	(2X5-15121-00-00)	CRANKCASE 2	1	
3	99510-12016-00	PIN, DOWEL	2	
4	91316-06065-00	BOLT, SOCKET HEAD	6	
5	91316-06045-00	BOLT, SOCKET HEAD	1	
6	91316-06075-00	BOLT, SOCKET HEAD	3	
7	91316-06070-00	BOLT, SOCKET HEAD	2	
8	(2X5-15118-00-00)	HOLDER	1	
9	92501-08010-00	SCREW, PAN HEAD	1	
10	137-13115-00-00	CONNECTOR, SUCTION PIPE .	1	
11	(90445-08346-00)	HOSE	1	
12	(90462-08043-00)	CLAMP	1	
13	(2K7-15441-02-00)	HOLDER, CLCH CABLE	1	
14	90462-08042-00	CLAMP	1	
15	92995-06100-00	WASHER, SPRING	1	
16	97011-06016-00	BOLT	1	
17	(2K7-15113-00-00)	PLATE	1	
18	98580-06010-00	SCREW, PAN HEAD (92503-06010)	1	

CRANKCASE COVER

Ref. No.	Part Number	Description	Qty	Remarks
1	2X7-15411-00-00	COVER, CRANKCASE L	1	
2	2K7-15421-00-00	COVER, CRANKCASE R	1	
3	91316-06025-00	BOLT	1	
4	90110-06138-00	BOLT, HEX SKT HEAD	5	
5	2X7-15451-00-00	GASKET, CRCS COVER	1	
6	2K7-15431-01-00	COVER, CRANKCASE 3	1	
7	2K7-15462-00-00	GASKET, CRCS CVR 3	1	
8	91316-06025-00	BOLT	7	
9	99510-12016-00	PIN, DOWEL	2	
10	1G8-15362-00-00	PLUG, OIL LEVEL	1	
11	93210-14104-00	O-RING	1	
12	98580-06008-00	SCREW, PAN HEAD	1	
13	90430-06016-00	GASKET	1	

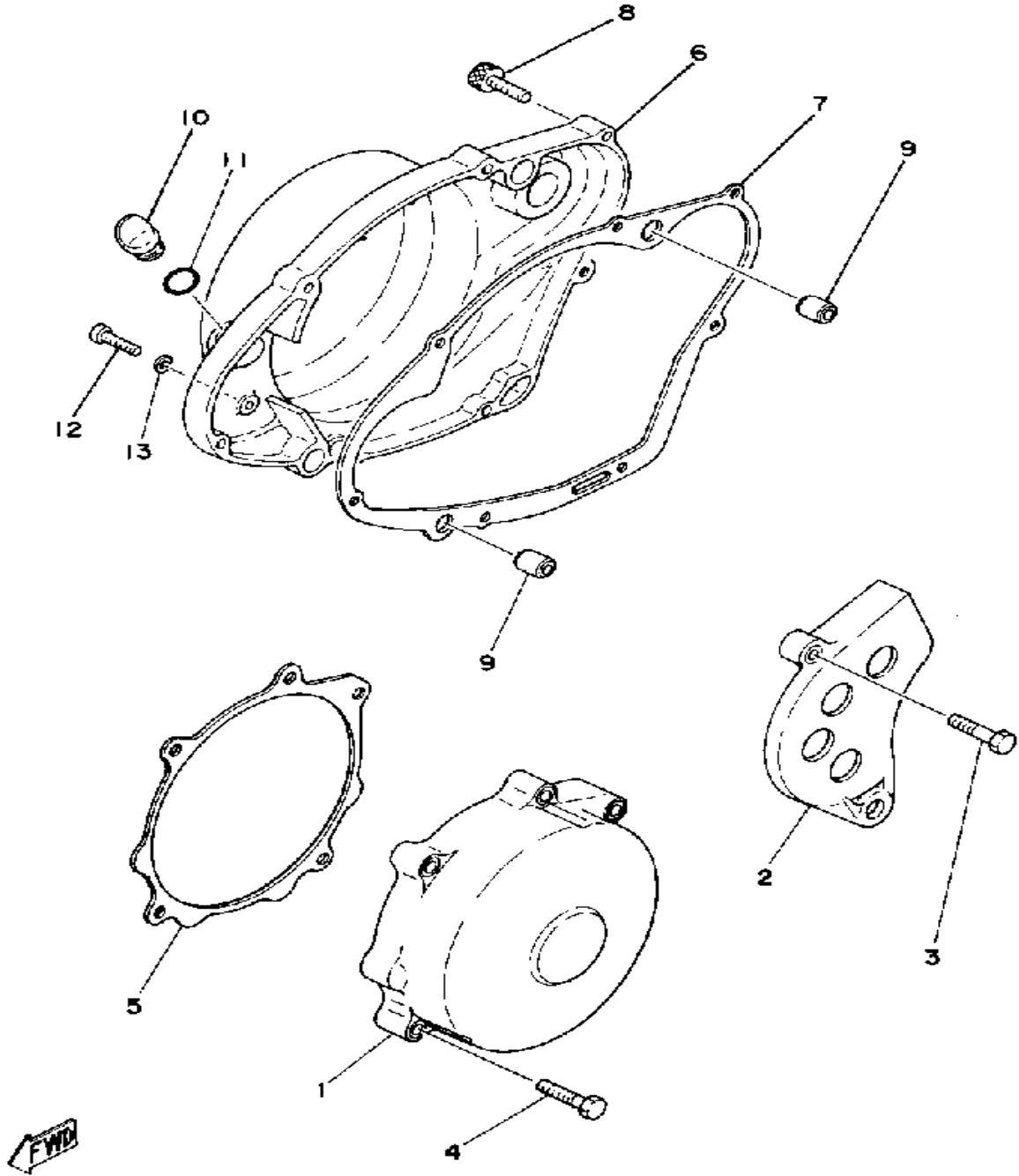

Piston Skirt Clearance new/max.	0.050 ~ 0.055mm / 0.1mm
Ring End Gap Top/2nd/3rd	0.40 ~ 0.55mm / 0.40 ~ 0.55mm / φ

SPECIAL SERVICE TOOLS
TLU-90900-57-01 CRANKSHAFT INSTALLING SET

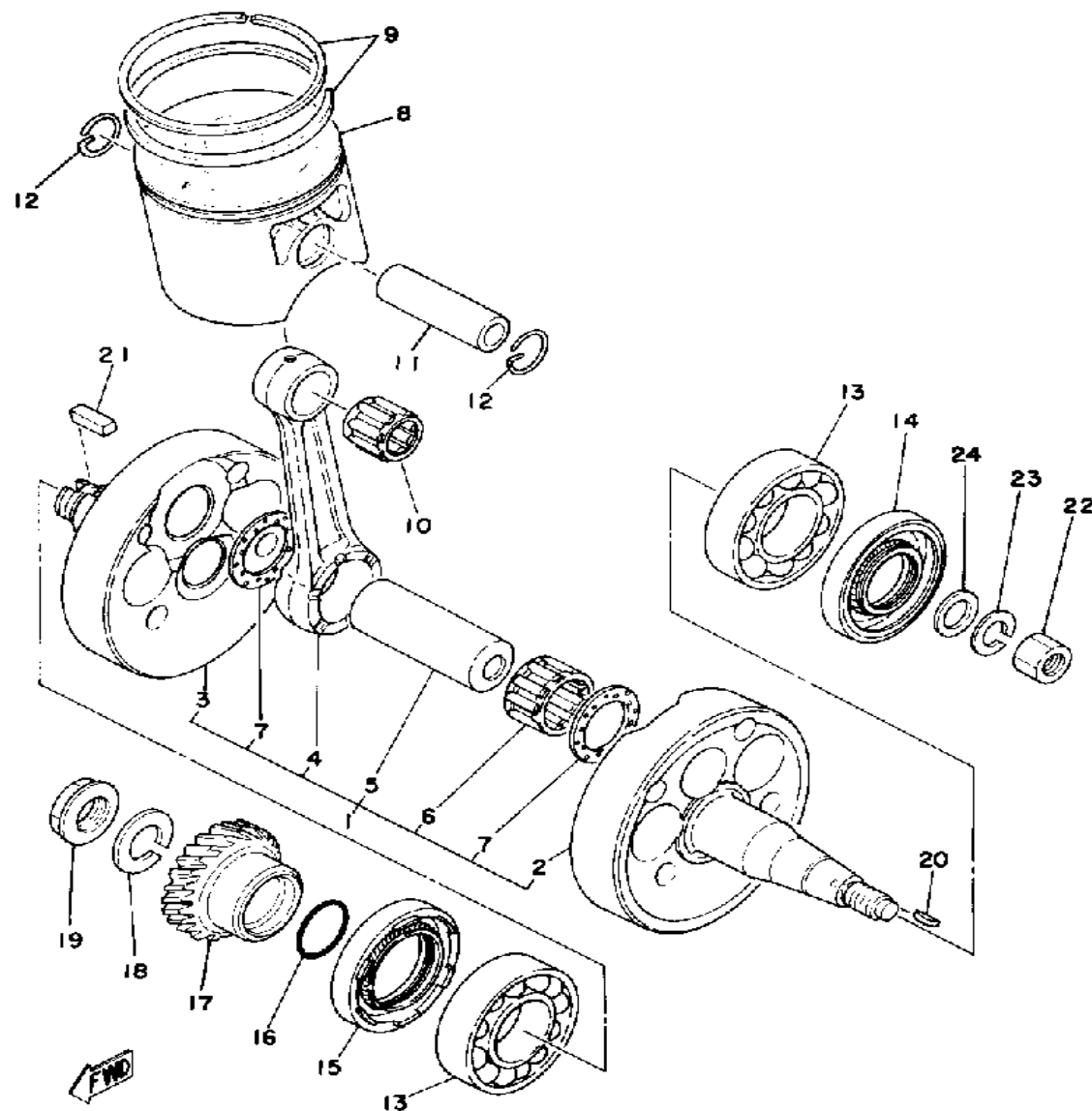

CRANK-PISTON

Ref. No.	Part Number	Description	Qty	Remarks
1	(2X5-11400-00-00)	CRANKSHAFT ASSEMBLY	1	
2	(2X5-11412-00-00)	CRANK 1	1	
3	(2X5-11422-00-00)	CRANK 2	1	
4	(2X5-11651-10-00)	ROD, CONNECTING	1	
5	(2X5-11681-00-00)	PIN, CRANK 1	1	
6	93310-425N4-00	. BEARING, CYLINDER.# 0	1	
7	90209-25085-00	. WASHER	2	
8	(2X8-11636-00-00)	PISTON 2 O/S 0. 0	1	ALTERNATE PARTS
	(2X8-11637-00-00)	PISTON 3 O/S 0. 5	1	ALTERNATE PARTS
	(2X8-11638-00-00)	PISTON 4 O/S 1. 0	1	ALTERNATE PARTS
	2X8-11631-00-96	PISTON STD	1	
	2X8-11635-00-00	PISTON 1 O/S 0. 5	1	ALTERNATE PARTS
9	(2X8-11610-30-00)	PISTON RINGSET 3RD	1	ALTERNATE PARTS
	(2X8-11610-40-00)	PISTON RINGSET 4TH	1	ALTERNATE PARTS
	2X8-11610-00-00	PISTON RINGSET STD	1	
	2X8-11610-10-00	PISTON RINGSET 1ST	1	ALTERNATE PARTS
	2X8-11610-20-00	PISTON RINGSET 2ND	1	ALTERNATE PARTS
10	93310-418E9-00	BEARING, CYLINDRICAL	1	
11	275-11633-00-00	PIN, PISTON (1W4-11633-00)	1	
12	93450-19052-00	CIRCLIP	2	
13	93306-30615-00	BEARING (B6306)	2	
14	93103-30150-00	OIL SEAL (38W)	1	
15	93103-40091-00	OIL SEAL, SW-TYPE	1	
16	93210-29282-00	O-RING	1	
17	(2X5-16111-00-00)	GEAR, PRI DRIVE	1	
18	92901-18100-00	WASHER, SPRING	1	
19	90179-18172-00	NUT	1	
20	90280-16053-00	KEY, WOODRUFF	1	
21	90282-07019-00	KEY, STRAIGHT	1	

CONTINUED ON NEXT FRAME ➤

Piston Skirt Clearance new/max.	0.050 ~ 0.055mm / 0.1mm
Ring End Gap Top/2nd/3rd	0.40 ~ 0.55mm / 0.40 ~ 0.55mm / φ

SPECIAL SERVICE TOOLS
TLU-90900-57-01 CRANKSHAFT INSTALLING SET

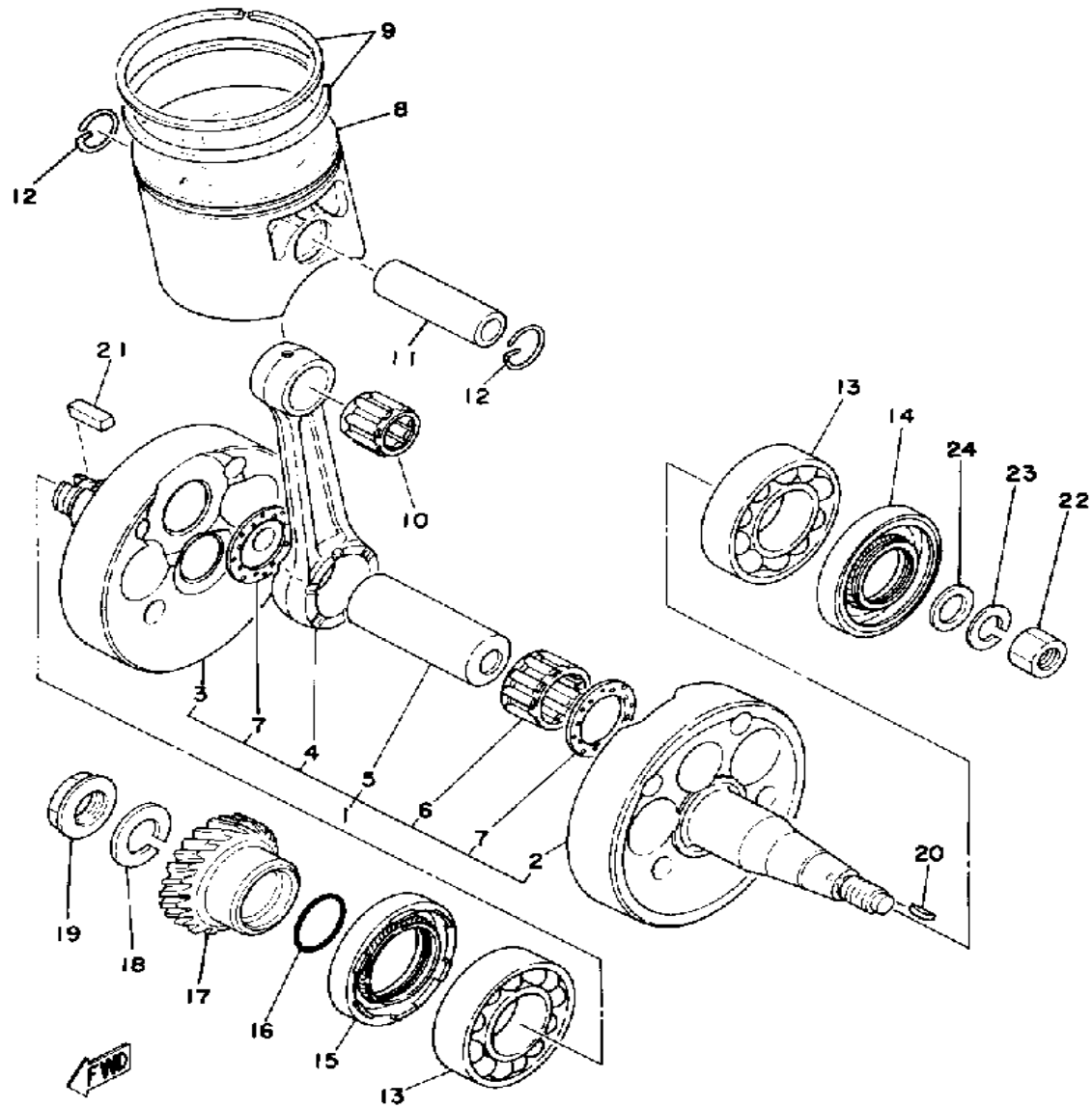

CRANK-PISTON

Ref. No.	Part Number	Description	Qty	Remarks
22	90170-12347-00	NUT, HEXAGON	1	
23	92901-12100-00	WASHER, SPRING	1	
24	90201-12593-00	WASHER, PLATE	1	

CLUTCH

SPECIAL SERVICE TOOLS
TLM-90910-42-00 CLUTCH HUB HOLDER

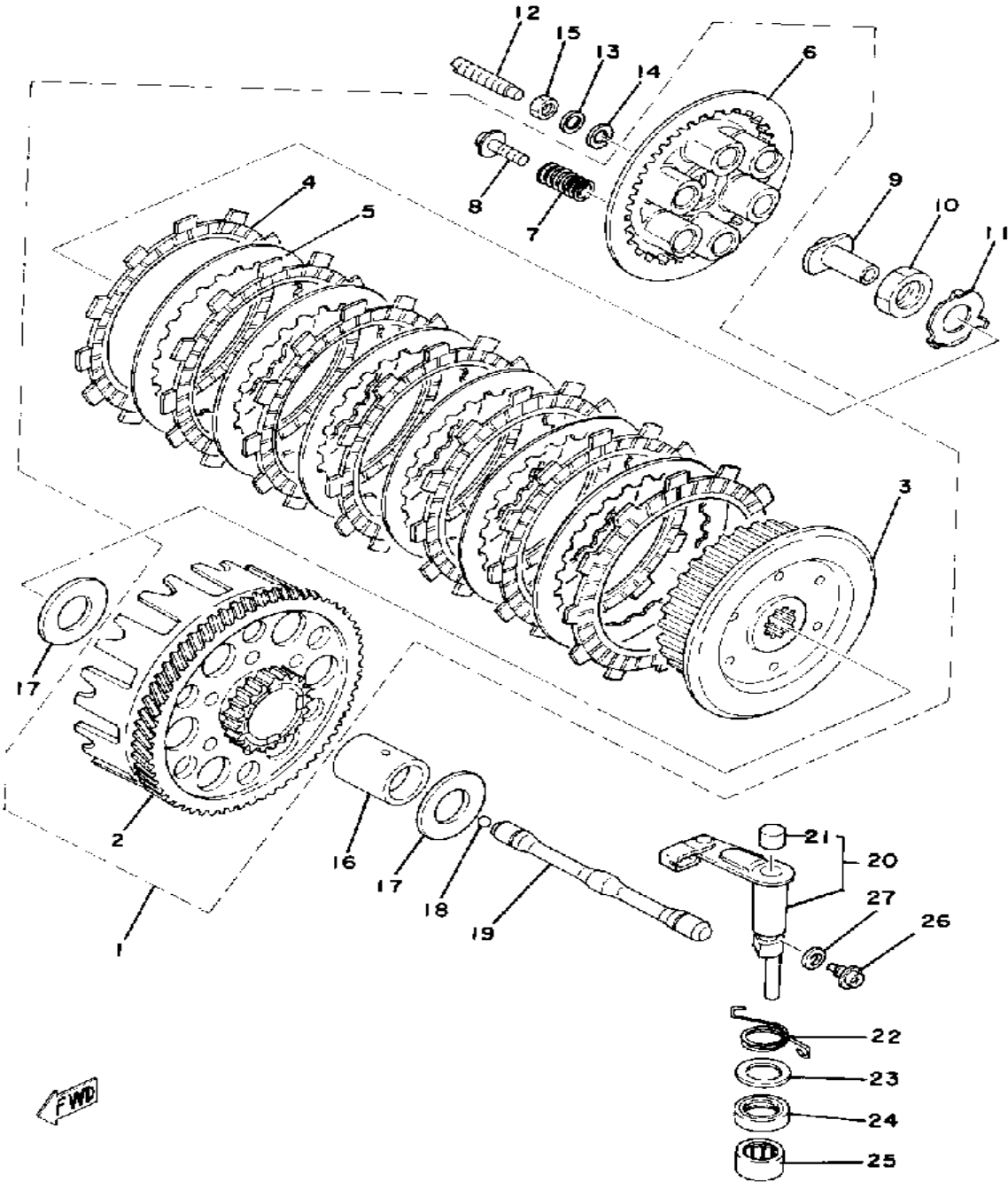

Ref. No.	Part Number	Description	Qty	Remarks
1	(2X5-16300-00-00)	CLUTCH ASSEMBLY	1	
2	2K7-16150-00-00	. PRI DRVN GEAR	1	
3	2X5-16371-00-00	. BOSS, CLUTCH	1	
4	4H7-16321-01-00	. PLATE, FRICTION	7	
5	360-16325-00-00	. PLATE, CLUTCH 2	6	
6	1M1-16351-00-00	. PLATE, PRESSURE 1	1	
7	90501-24408-00	. SPRING, COMPRESSION	6	
8	90159-06016-00	. SCREW, WITH WASHER	6	
9	1M1-16356-00-00	ROD, PUSH 1	1	
10	90170-20195-00	NUT, HEXAGON	1	
11	90215-20125-00	WASHER, LOCK	1	
12	90149-08105-00	SCREW, SPEC'L SHAPE	1	
13	90201-087H6-00	WASHER, PLATE	1	
14	92990-08100-00	WASHER	1	
15	95311-08700-00	NUT	1	
16	2K7-16181-00-00	SPACER 1	1	
17	2K7-16154-00-00	PLATE, THRUST 1	2	
18	93515-32029-00	BALL	1	
19	1W4-16357-00-00	ROD, PUSH 2	1	
20	2X4-16380-00-00	PUSH LEVER ASSEMBLY	1	
21	214-17481-00-00	. PLUG, BLIND	1	
22	90508-14373-00	SPRING, TORSION	1	
23	90201-17327-00	WASHER, PLATE	1	
24	93102-17004-00	OIL SEAL	1	
25	93315-21721-00	BEARING, CYLINDER.# 5	1	
26	90149-08108-00	SCREW, SPEC'L SHAPE	1	
27	90430-08069-00	GASKET	1	

TRANSMISSION

TRANSMISSION - Oil Type/Qty Chg/Qty Reassemble	SAE 10W30 SE / 800cc / 860cc
Primary Drive Type/Teeth/Ratio	Helical Gear / 60-23 / 2.608
Secondary Drive Type/Teeth/Chain	Chain / 46-14 / DID520TR-102L

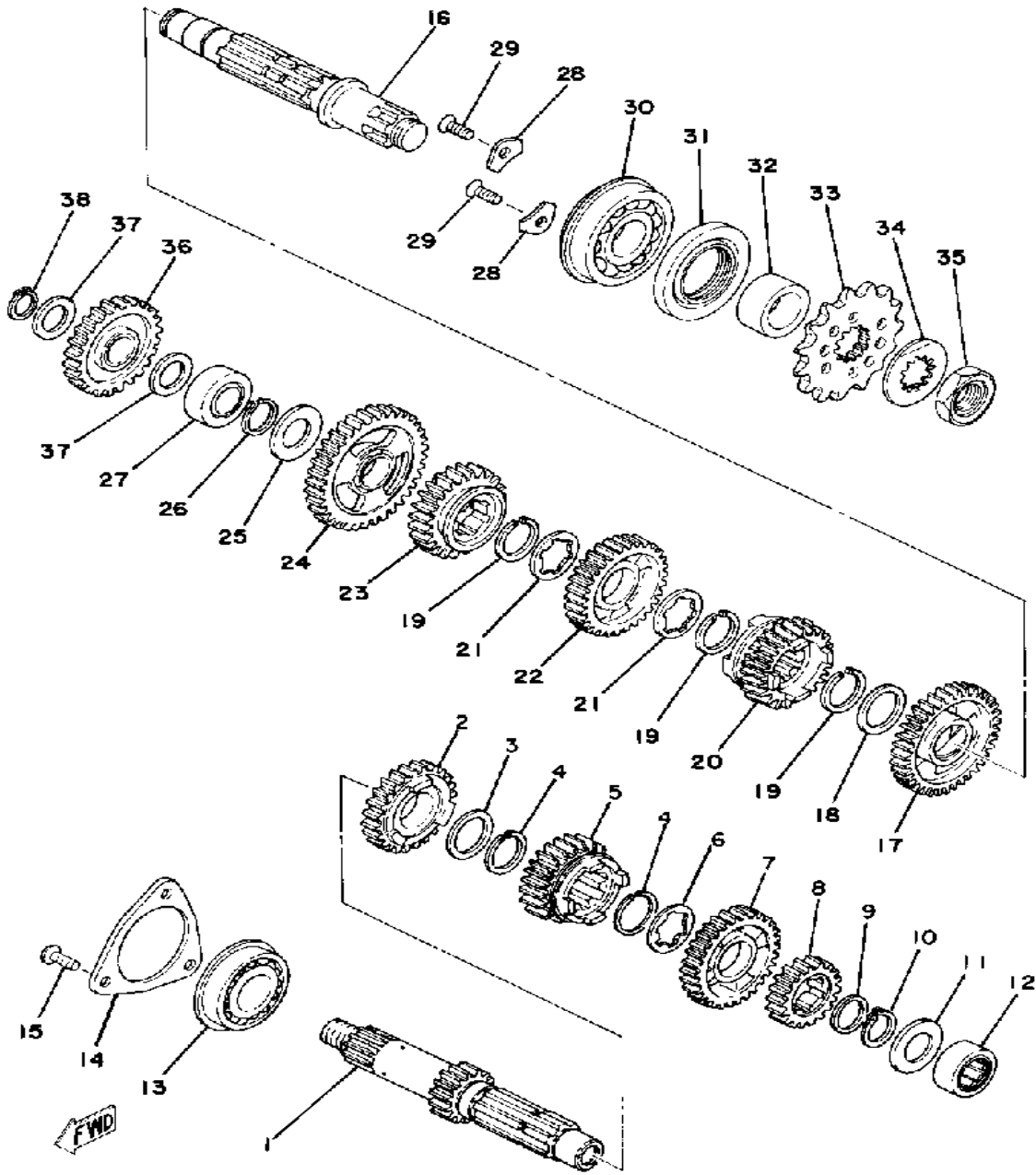

Ref. No.	Part Number	Description	Qty	Remarks
1	(2X8-17411-00-00)	AXLE, MAIN	1	
2	2X8-17141-00-00	GEAR, 4TH PINION	1	
3	90201-253K0-00	WASHER, PLATE (T=1.0)	1	
4	93440-25084-00	CIRCLIP	2	
5	(2X5-17131-01-00)	GEAR, 3RD PINION	1	
6	90209-22082-00	WASHER (0.5T)	1	
7	(2X8-17151-01-00)	GEAR, 5TH PINION	1	
8	(2X5-17121-00-00)	GEAR, 2ND PINION	1	
9	90201-20613-00	WASHER, PLATE	1	
10	93410-20038-00	CIRCLIP	1	
11	90201-20278-00	WASHER, PLATE	1	
12	93311-62035-00	BEARING, CYLINDER.# 1	1	
13	93306-20535-00	BEARING (93306-20515)	1	
14	1W4-15383-00-00	PLATE, BRNG COVER	1	
15	98603-06012-00	SCREW, OVAL HEAD (92701-06012)	3	
16	2X5-17421-00-00	AXLE, DRIVE	1	
17	2X5-17221-00-00	GEAR, 2ND WHEEL	1	
18	90201-253K0-00	WASHER, PLATE (T=1.0)	1	
19	93440-25084-00	CIRCLIP	3	
20	(2X8-17251-01-00)	GEAR, 5TH WHEEL	1	
21	90209-22082-00	WASHER (0.5T)	2	
22	2X5-17231-00-00	GEAR, 3RD WHEEL	1	
23	(2X8-17241-00-00)	GEAR, 4TH WHEEL	1	
24	(2X8-17211-00-00)	GEAR, 1ST WHEEL	1	
25	90201-20278-00	WASHER, PLATE	1	
26	93410-20038-00	CIRCLIP	1	
27	93311-62035-00	BEARING, CYLINDER.# 1	1	
28	2K7-15383-00-00	PLATE, BEARING COVER	2	

CONTINUED ON NEXT FRAME ➤

TRANSMISSION - Oil Type/Qty Chg/Qty Reassemble	SAE 10W30 SE / 800cc / 860cc
Primary Drive Type/Teeth/Ratio	Helical Gear / 60-23 / 2.608
Secondary Drive Type/Teeth/Chain	Chain / 46-14 / DID520TR-102L

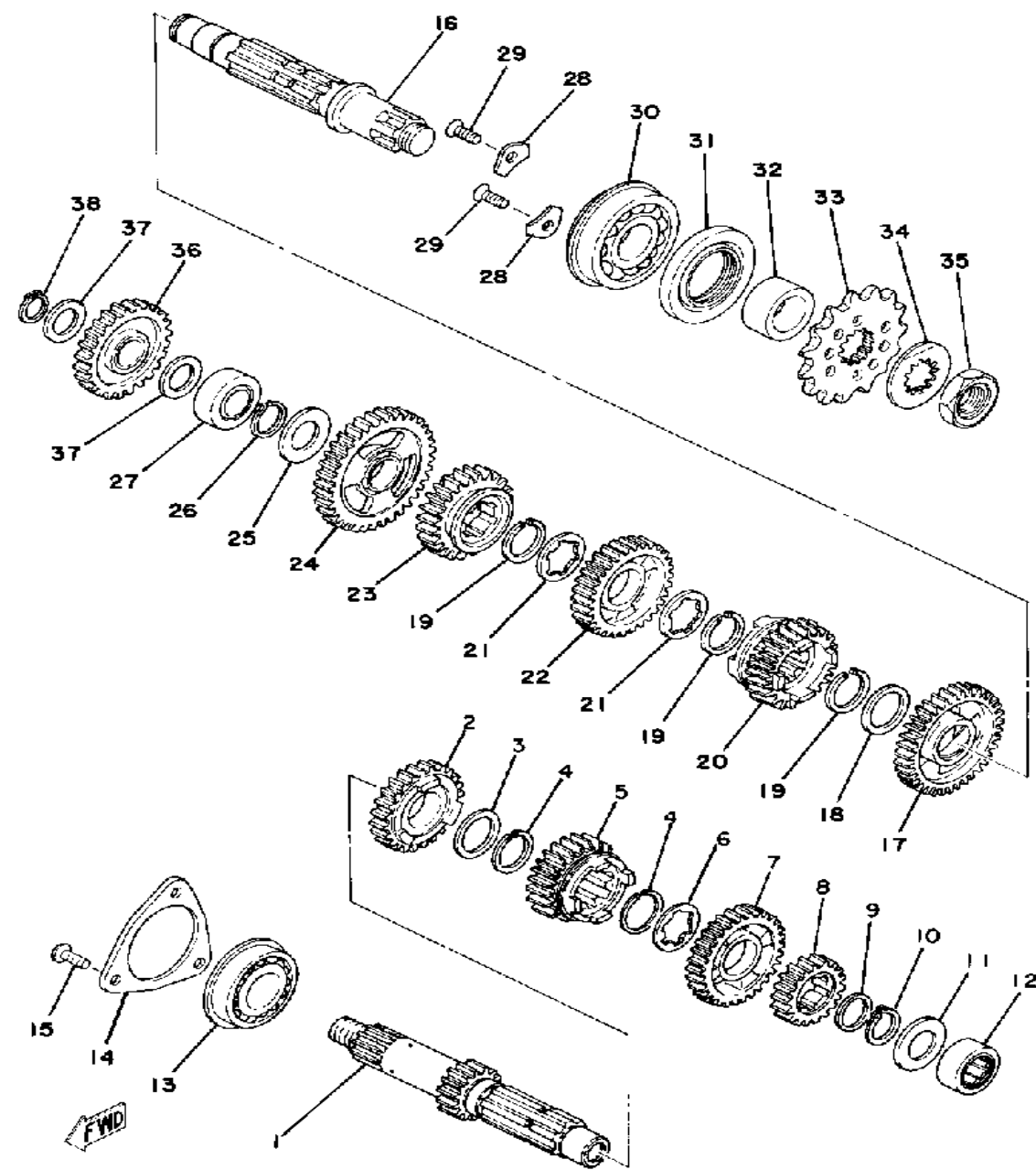

TRANSMISSION

Ref. No.	Part Number	Description	Qty	Remarks
29	98603-06012-00	SCREW, OVAL HEAD (92701-06012)	2	
30	93304-20501-00	BEARING	1	
31	93102-32M07-00	OIL SEAL	1	
32	90387-25663-00	COLLAR	1	
33	93834-13030-00	SPROCKET, DRIVE 13T (23X1746130)	1	
	93834-14051-00	SPROCKET, DRIVE (23X-17461-40)	1	STD
	93834-15078-00	SPROCKET, DRIVE	1	
34	90215-21239-00	WASHER, LOCK	1	
35	90179-20255-00	NUT	1	
36	3R4-15651-00-00	GEAR, KICK IDLE	1	
37	90201-17545-00	WASHER, PLATE	2	
38	99009-17400-00	CIRCLIP	1	

SHIFTER 1

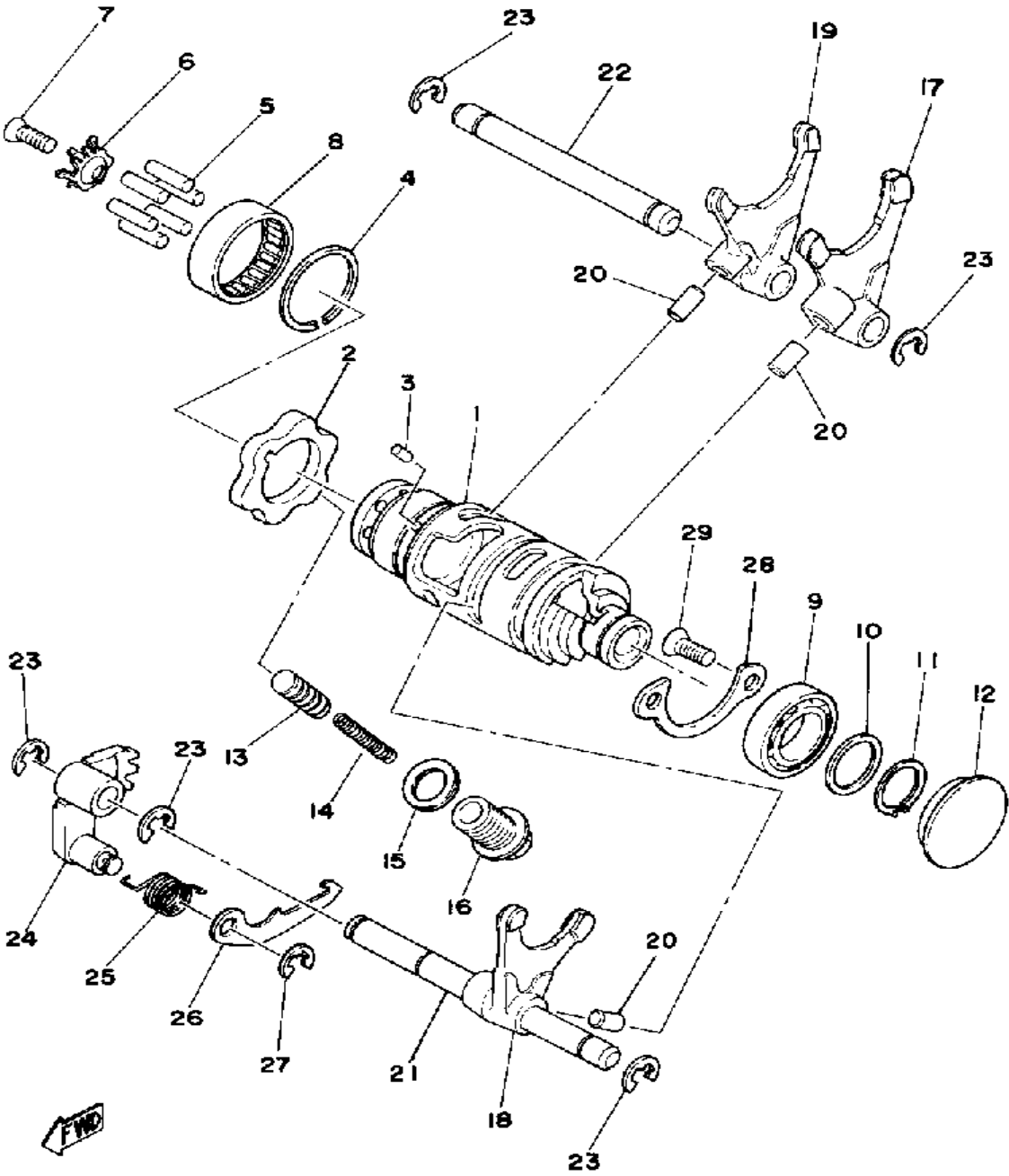

Ref. No.	Part Number	Description	Qty	Remarks
1	(2X5-18540-00-00)	SHIFT CAM ASSEMBLY	1	
2	2K7-18141-00-00	PLATE, STOPPER	1	
3	93604-08071-00	PIN, DOWEL	1	
4	93440-32017-00	CIRCLIP, OUTER (32V SPECIAL)	1	
5	93604-18100-00	PIN, DOWEL	6	
6	2K9-18561-00-00	PLATE, SIDE 1	1	
7	98701-05012-00	SCREW, FLAT HEAD	1	
8	93315-23208-00	BEARING	1	
9	93306-90403-00	BEARING	1	
10	90201-20613-00	WASHER, PLATE	1	
11	99009-19400-00	CIRCLIP	1	
12	(90338-32086-00)	PLUG, SPEC'L SHAPE	1	
13	353-18547-00-00	STOPPER, CAM	1	
14	90501-10062-00	SPRING, COMPRESSION	1	
15	214-11198-01-00	GASKET	1	
16	90109-14485-00	BOLT	1	
17	2X5-18511-00-00	FORK, SHIFT 1	1	
18	2X5-18512-00-00	FORK, SHIFT 2	1	
19	(2X5-18513-00-00)	FORK, SHIFT 3	1	
20	93606-14154-00	PIN, DOWEL	3	
21	(2K7-18531-00-00)	BAR, SHIF FRK GDE 1	1	
22	2K7-18535-01-00	BAR, SHIF FRK GDE 2	1	
23	99001-08600-00	CIRCLIP	5	
24	2K7-18122-01-00	LEVER, SHIFT 2 (2K7-18122-00)	1	
25	(90508-10386-00)	SPRING, TORSION	1	
26	2K7-18151-00-00	LEVER, SHIFT 3	1	
27	99080-07600-00	CIRCLIP (E)	1	
28	(2K7-15381-00-00)	PLATE, BRNG COVER	1	

CONTINUED ON NEXT FRAME ►

SHIFTER 1

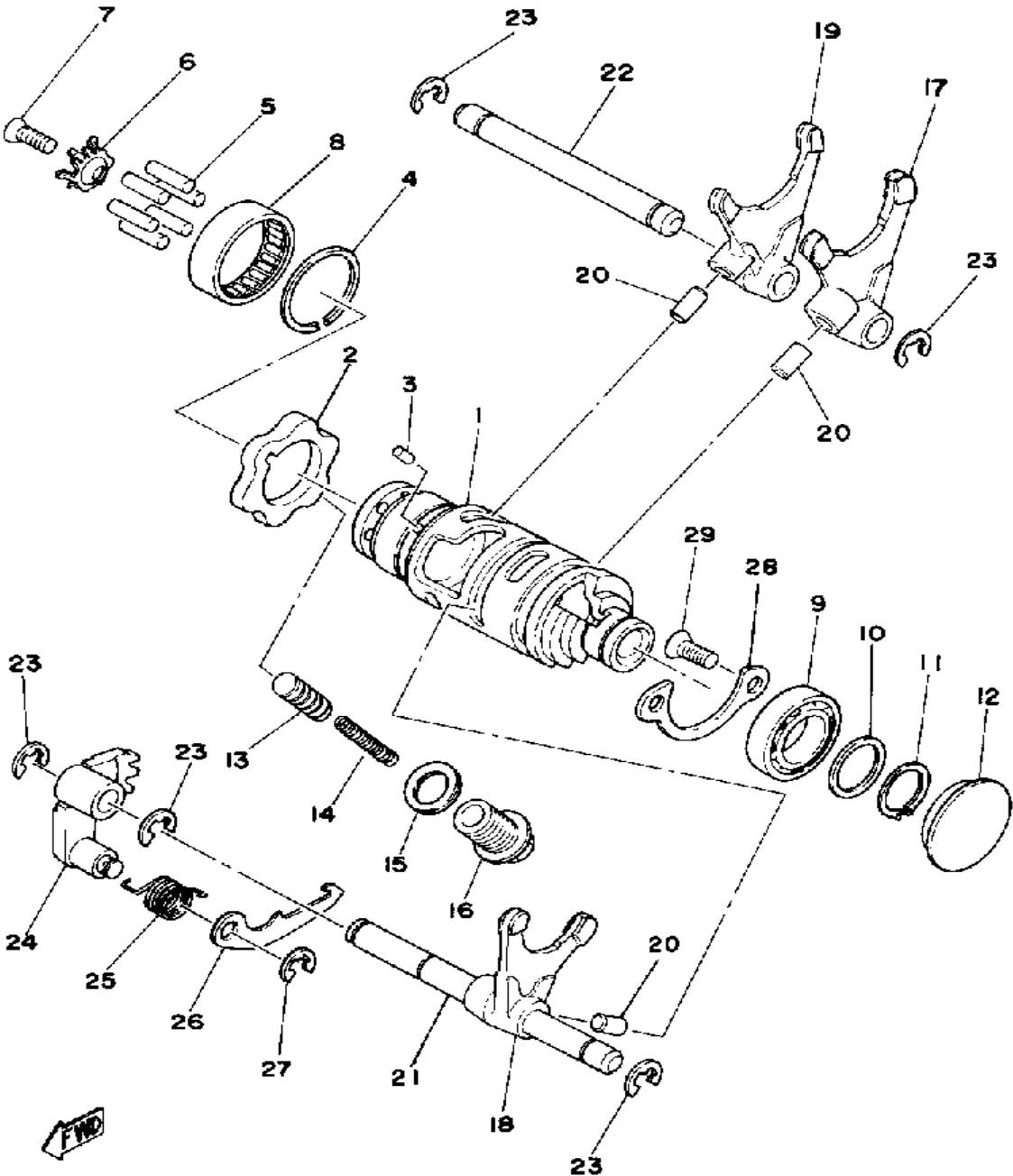

Ref. No.	Part Number	Description	Qty	Remarks
29	98603-06012-00	SCREW, OVAL HEAD (92701-06012)	2	

SHIFTER 2

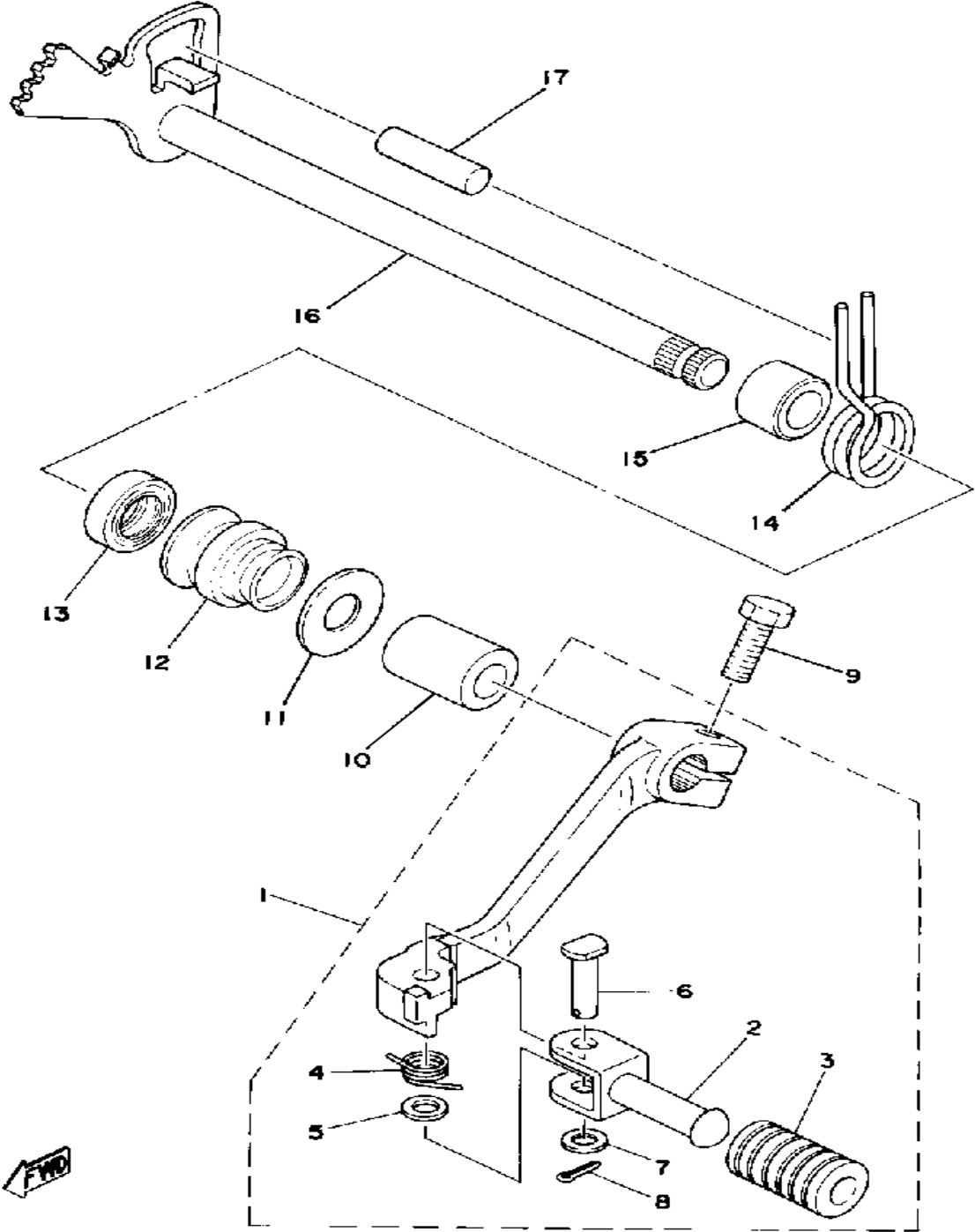

Ref. No.	Part Number	Description	Qty	Remarks
1	2HF-18110-01-00	SHIFT PEDAL ASSEMBLY	1	
2	1W6-18162-00-00	. PEDAL, SHIFT	1	
3	1W6-18113-00-00	. COVER, SHIFT PEDAL	1	
4	90508-16351-00	. SPRING, TORSION	1	
5	92990-06200-00	. WASHER	1	
6	90240-06057-00	. PIN, CLEVIS	1	
7	92901-06600-00	. WASHER	1	
8	91490-20020-00	. PIN, COTTER	1	
9	97011-06020-00	BOLT	1	
10	90560-12191-00	SPACER	1	
11	90201-12588-00	WASHER, PLATE	1	
12	214-18131-00-00	BOOT, SEALING	1	
13	93102-12321-00	OIL SEAL, SD-TYPE	1	
14	90508-32374-00	SPRING, TORSION	1	
15	90560-12171-00	SPACER	1	
16	2K7-18101-00-00	SHIFT SHAFT ASSEMBLY 1	1	
17	93608-30152-00	PIN, DOWEL	1	



KICK STARTER

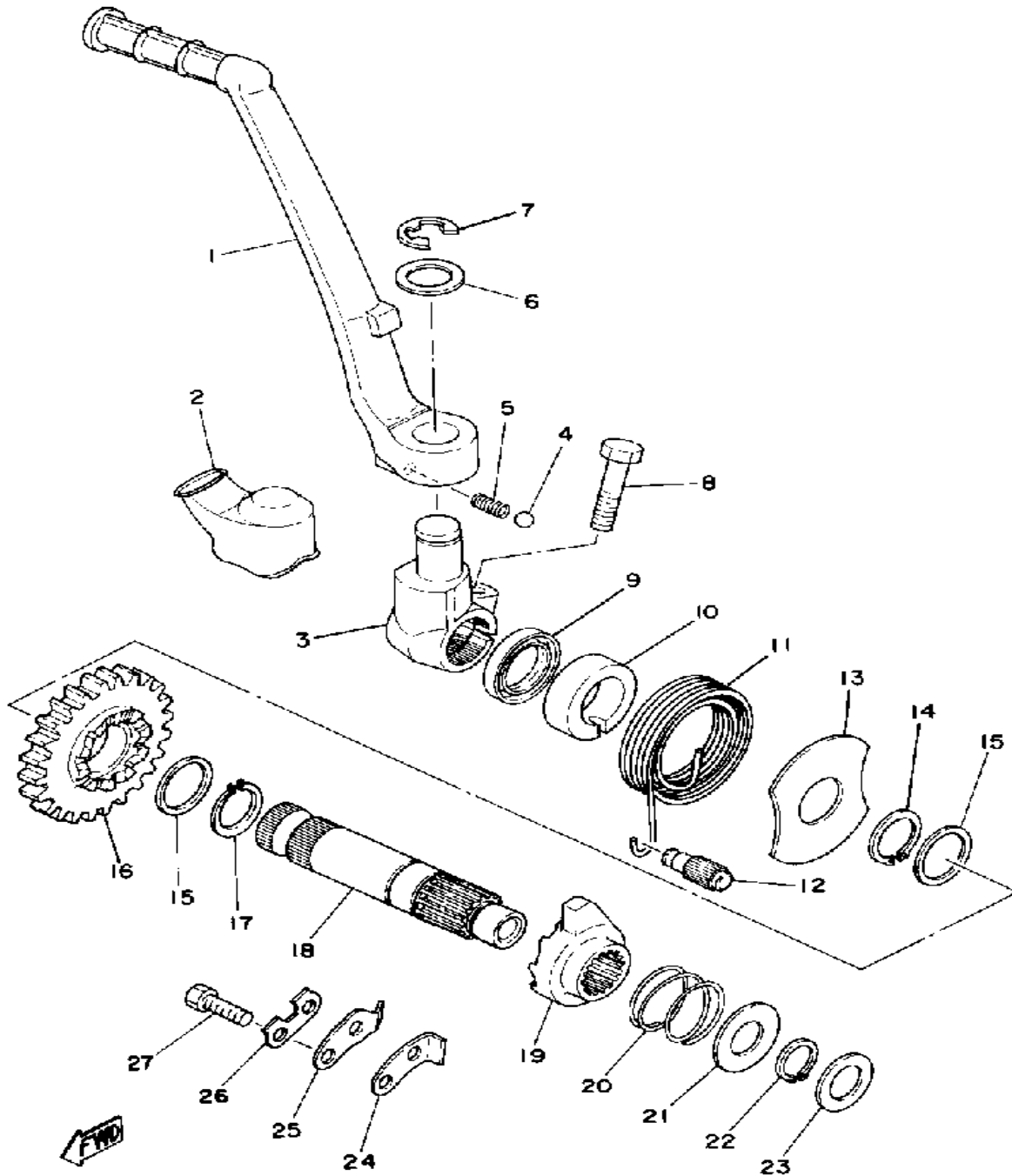

Ref. No.	Part Number	Description	Qty	Remarks
1	2K7-15611-00-00	CRANK, KICK (2K7-15611-00-33)	1	YAMAHA BLACK
2	2K7-15618-00-00	COVER, KICK LEVER	1	
3	2K7-15621-00-00	BOSS, KICK CRANK	1	
4	93507-32031-00	BALL	1	
5	90501-12081-00	SPRING, COMPRESSION	1	
6	90201-15234-00	WASHER, PLATE	1	
7	99006-10600-00	CIRCLIP	1	
8	97313-08030-00	BOLT, HEXAGON	1	
9	93102-20309-00	SEAL, OIL	1	
10	3Y6-15664-00-00	GUIDE, SPRING	1	
11	90508-32061-00	SPRING, TORSION (291-15665-00)	1	
12	248-15668-00-00	STOPPER	1	
13	2K7-15676-00-00	COVER, SPRING	1	
14	99009-20400-00	CIRCLIP	1	
15	90201-20685-00	WASHER, PLATE (0.5T)	2	
16	(2K7-15641-01-00)	GEAR, KICK	1	
17	93410-20038-00	CIRCLIP	1	
18	(2K7-15661-01-00)	AXLE, KICK	1	
19	2K7-15671-01-00	WHEEL, RATCHET	1	
20	90501-16107-00	SPRING, COMPRESSION	1	
21	90201-155K6-00	WASHER, PLATE	1	
22	99009-15400-00	CIRCLIP	1	
23	132-15644-00-00	SHIM	1	
24	2NX-15668-00-00	STOPPER	1	
25	2NX-15674-00-00	GUIDE, RATCHET WHEEL	1	
26	214-15686-00-00	WASHER, LOCK	1	
27	97313-06016-00	BOLT, HEXAGON	2	

INTAKE

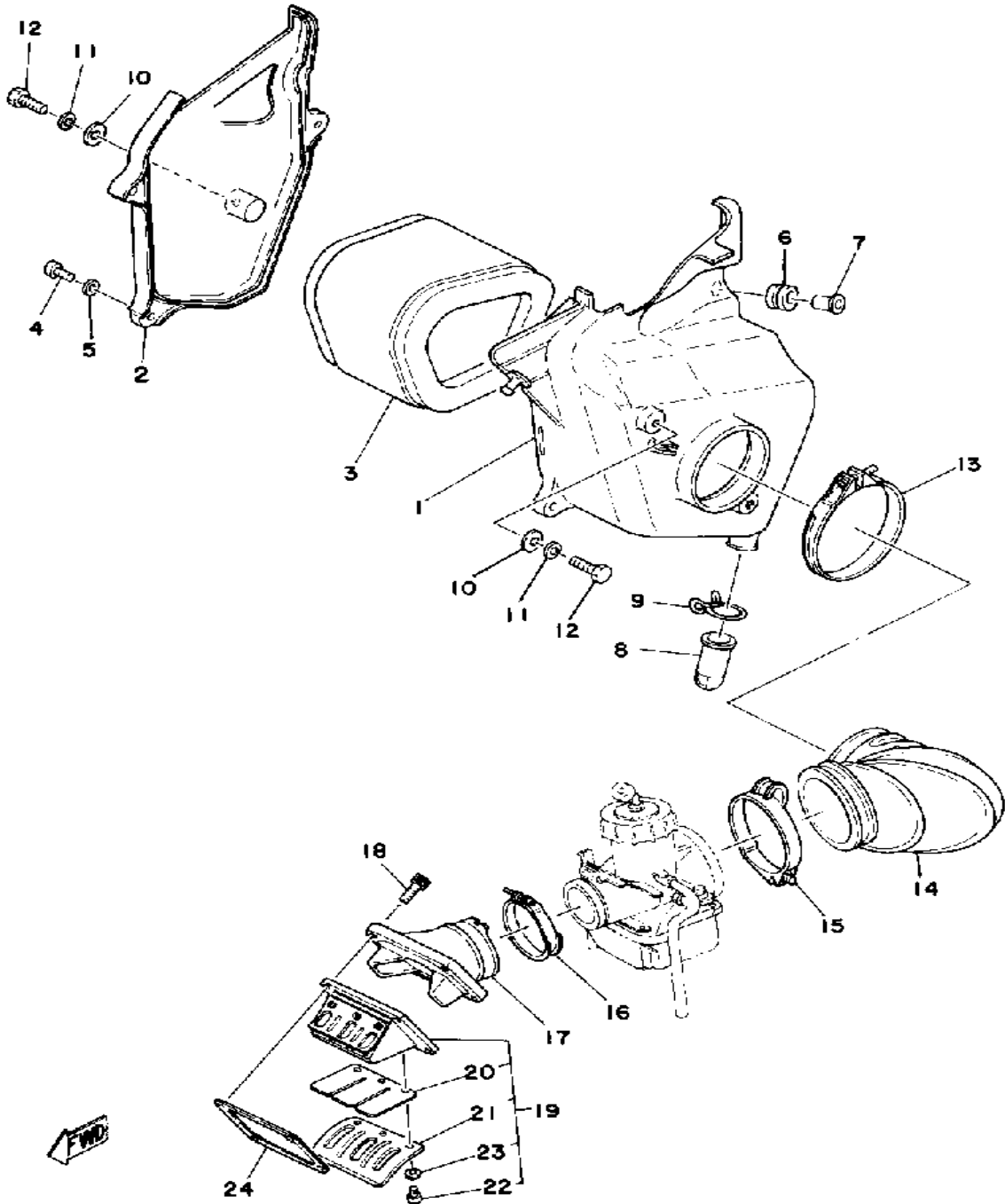

Ref. No.	Part Number	Description	Qty	Remarks
1	(2K7-14411-01-00)	CASE, AIR CLEANER 1	1	
2	2K7-14412-00-00	CAP, CLEANER CASE 1	1	
3	2K7-14450-00-00	ELEMENT ASSEMBLY	1	
4	98503-06014-00	SCREW, PAN HEAD (92502-06016)	3	
5	92901-06600-00	WASHER	3	
6	90480-14023-00	GROMMET	3	
7	90387-07391-00	COLLAR	3	
8	1W4-14457-00-00	SEAL	1	
9	90467-20030-00	CLIP	1	
10	90201-06067-00	WASHER, PLATE	3	
11	92995-06100-00	WASHER, SPRING	3	
12	97011-06025-00	BOLT (97001-06025)	3	
13	90460-85277-00	CLAMP, HOSE	1	
14	(2X5-14453-00-00)	JOINT, AIR CLNR 1	1	
15	90460-68231-00	CLAMP, HOSE	1	
16	90460-51109-00	CLAMP, HOSE	1	
17	2K7-13565-00-00	JOINT, CARBURETOR	1	
18	97011-06020-00	BOLT	4	
19	2X5-13610-00-00	REED VALVE ASSEMBLY	1	
20	2K7-13613-00-00	. REED, VALVE	2	
21	2X5-13616-00-00	. STOPPER, REED VALVE	2	
22	98580-03008-00	. SCREW, PAN HEAD	6	
23	92990-03100-00	. WASHER, SPRING (92901-03100)	6	
24	80L-13621-01-00	GASKET, VALVE SEAT	1	

CARBURETOR

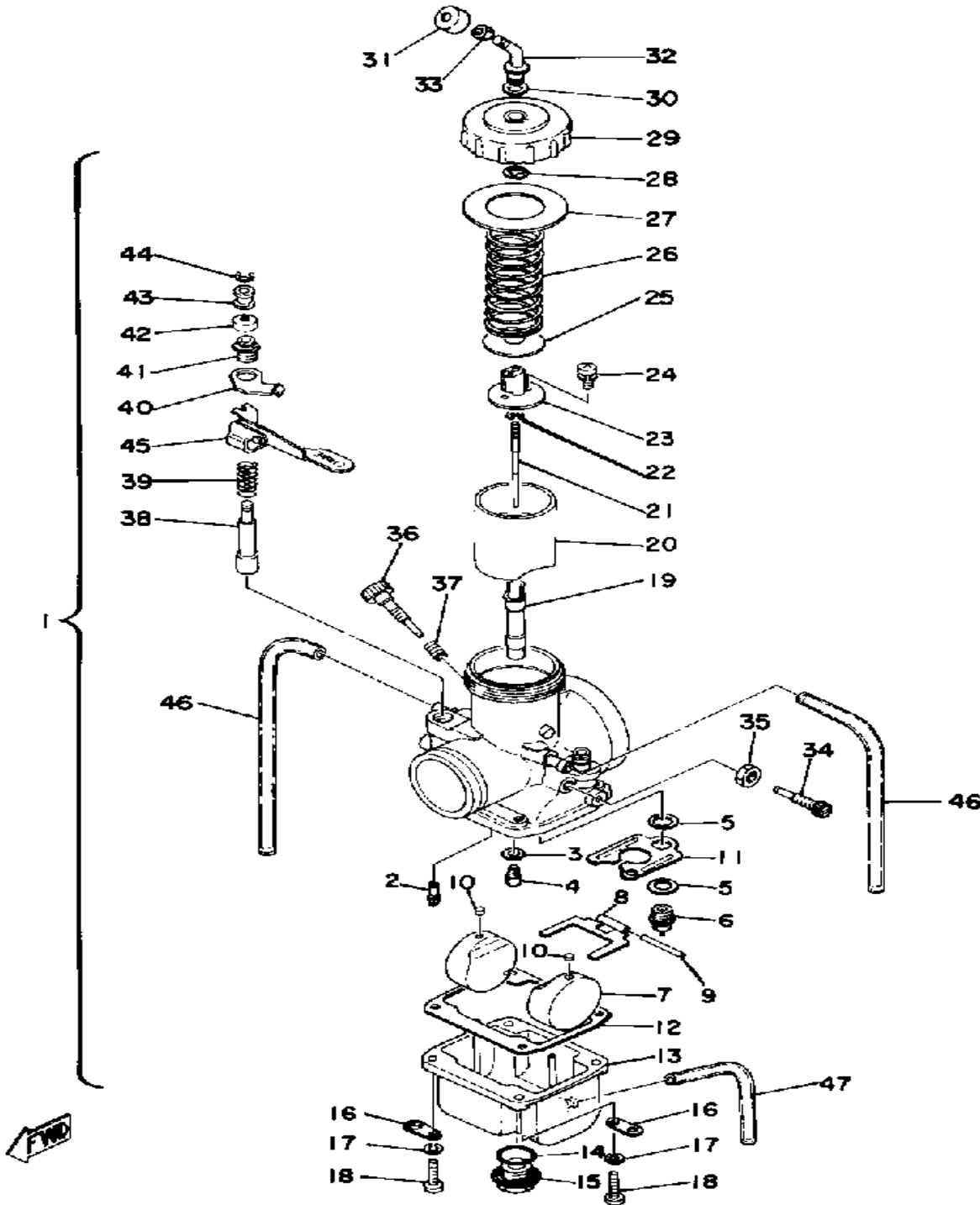

Ref. No.	Part Number	Description	Qty	Remarks
1	(2X8-14101-00-00)	CARBURETOR ASSEMBLY 1	1	
2	193-14142-50-00	. JET, PILOT (# 50)	1	
3	509-14145-00-00	. SETTER, NEEDLE JET	1	
4	137-14143-68-00	. JET, MAIN (#340)	1	
	137-14143-70-00	. JET, MAIN (#350)	1	STD
	137-14143-72-00	. JET, MAIN (#360)	1	
5	239-14195-00-00	. WASHER, NEEDLE VALVE	2	
6	23X-14107-35-00	. NEEDLE VALVE SET	1	
7	214-14185-00-00	. FLOAT	2	
8	363-14187-00-00	. ARM, FLOAT	1	
9	127-14186-00-00	. PIN, FLOAT	1	
10	214-14118-00-00	. CAP	2	
11	510-14146-00-00	. PLATE	1	
12	363-14184-00-00	. GASKET, FLOAT CHMBR	1	
13	(510-14181-16-00)	BODY, FLOAT CHMBR 1	1	
14	558-14147-00-00	. O-RING	1	
15	500-14115-00-00	. PLUG, SCREW	1	
16	313-14146-00-00	. PLATE	2	
17	92990-05100-00	. WASHER, SPRING	4	
18	98580-05016-00	. SCREW, PAN HEAD	4	
19	510-14141-44-00	. NOZZLE, MAIN	1	
20	510-14112-30-00	. VALVE, THROTTLE 1 (3.0)	1	
21	239-14116-16-00	. NEEDLE	1	
22	164-14137-00-00	. CLIP	1	
23	509-14274-00-00	. CONNECTOR	1	
24	98580-03008-00	. SCREW, PAN HEAD	2	
25	509-14136-00-00	. SEAT, SPRING	1	
26	363-14131-00-00	. SPRING, THROTTLE VALVE	1	
27	363-14126-00-00	. GASKET	1	

CONTINUED ON NEXT FRAME ➤

CARBURETOR

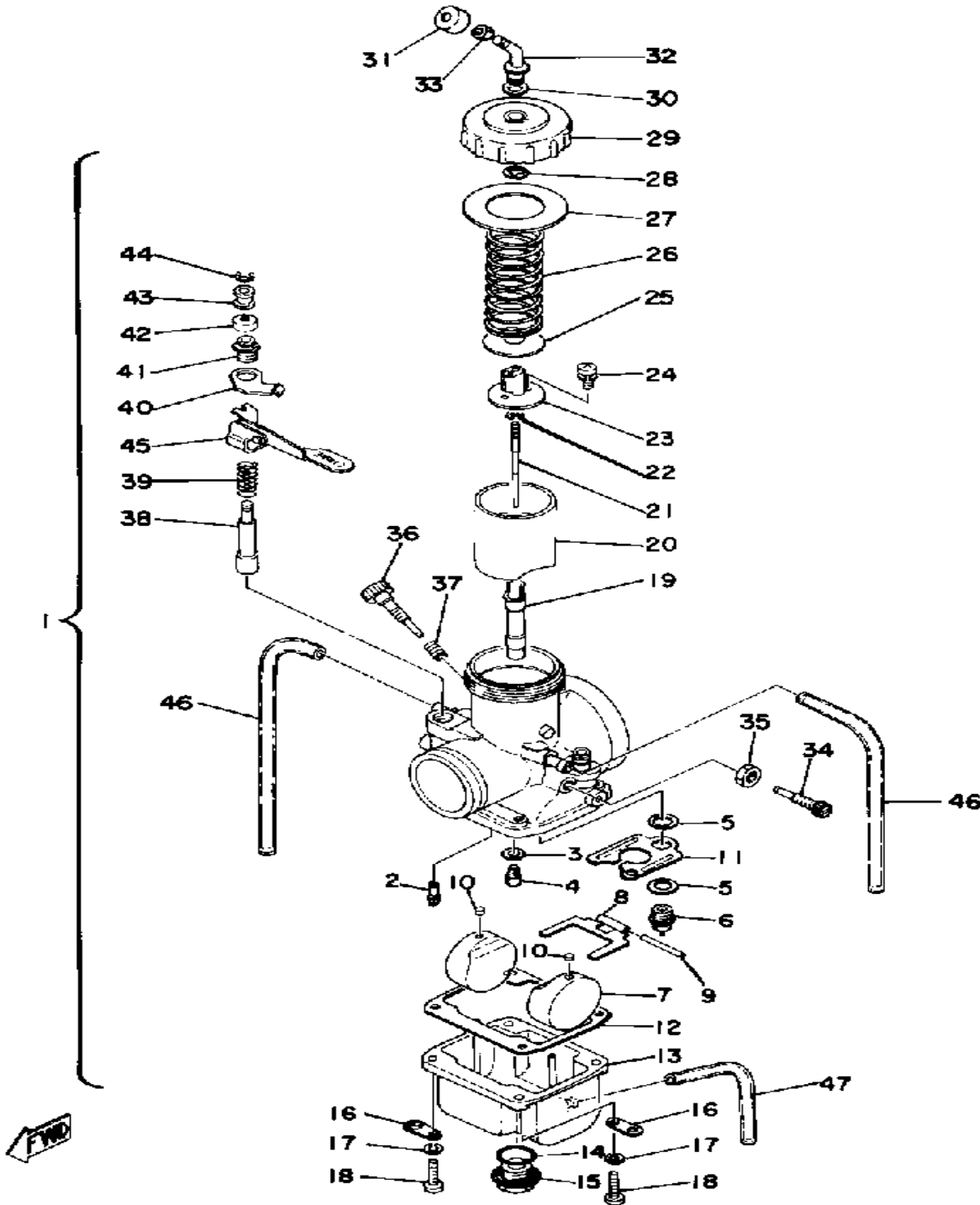

Ref. No.	Part Number	Description	Qty	Remarks
28	363-14137-00-00	. CLIP	1	
29	1W3-14158-00-00	. TOP, MIXING CHAMBER	1	
30	509-14198-00-00	. GASKET	1	
31	1M1-14169-00-00	. CAP	1	
32	23X-14106-00-00	. CABLE ADJUST SCREW SET	1	
33	127-14161-00-00	. NUT, CABLE ADJUSTING ...	1	
34	23X-14103-00-00	. THROTTLE SCREW SET	1	
35	802-14161-00-00	. NUT, CABLE ADJUSTING ...	1	
36	26A-14104-00-00	. AIR SCREW SET (1W3-14123-00)	1	
37	137-14133-00-00	. SPRING, THRTL STOP	1	
38	1W1-14171-00-00	. PLUNGER, STARTER	1	
39	256-14135-00-00	. SPRING, PLUNGER	1	
40	(1W3-14178-00-00)	PLATE, STARTER LVR	1	
41	802-14174-00-00	. CAP, PLUNGER	1	
42	802-14173-00-00	. COVER, PLUNGER CAP	1	
43	737-14241-00-00	. BUSH	1	
44	737-14137-00-00	. CLIP	1	
45	1W3-14175-00-00	. COVER, PLUNGER CAP (1W3-14173-00-00)	1	
46	310-14197-00-00	. PIPE, AIRVENT	2	
47	510-14197-00-00	. PIPE (43214-19700-00)	1	

EXHAUST

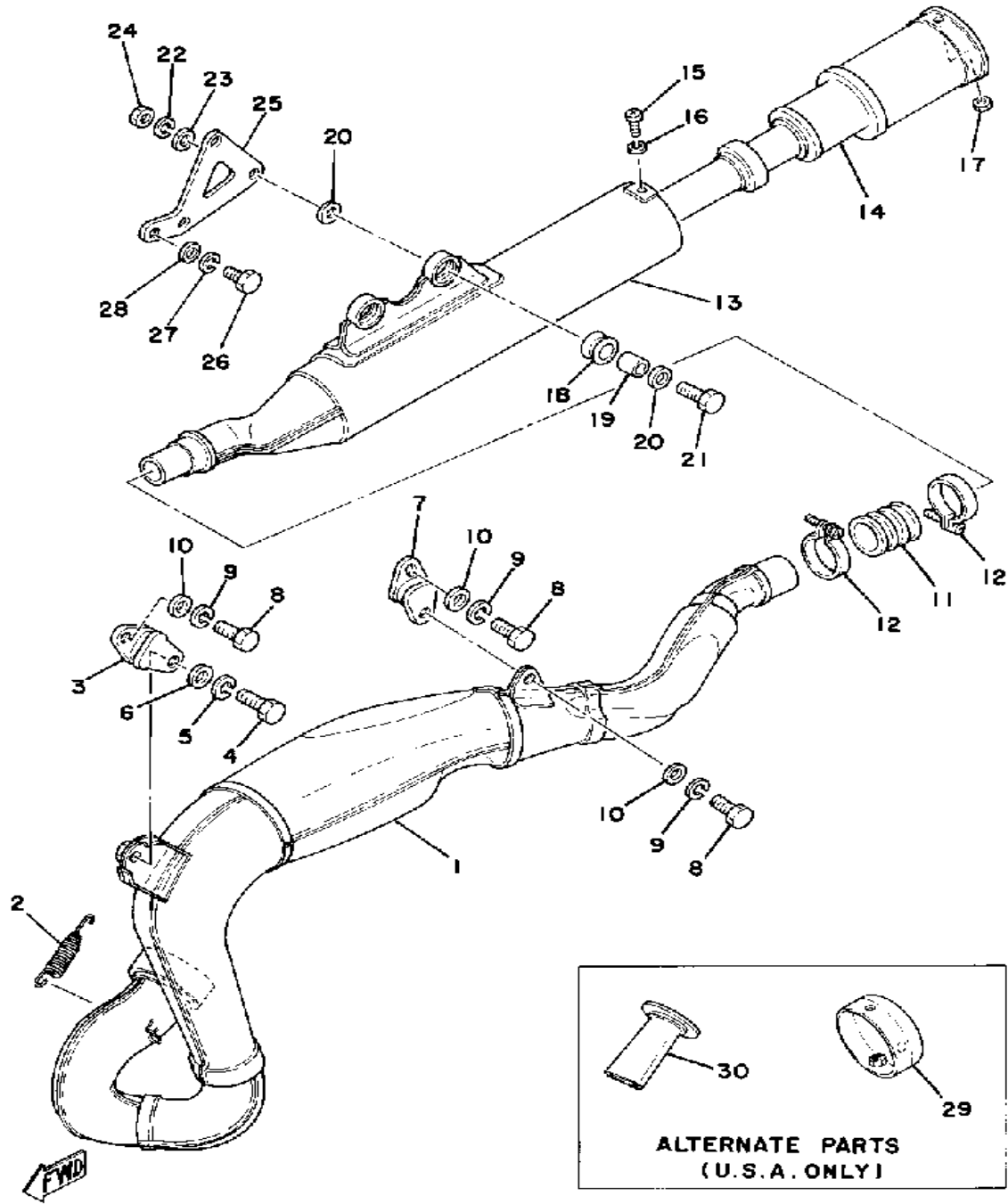

Ref. No.	Part Number	Description	Qty	Remarks
1	(2X8-14610-01-00)	EXHAUST PIPE ASSEMBLY L	1	
2	90507-20030-00	SPRING, TENSION	2	
3	483-14781-02-00	STAY, MUFFLER 2	1	
4	97313-08020-00	BOLT, HEXAGON	1	
5	92990-08100-00	WASHER	1	
6	92901-08600-00	WASHER	1	
7	565-14771-00-00	STAY, MUFFLER 1	1	
8	97313-06016-00	BOLT, HEXAGON	3	
9	92995-06100-00	WASHER, SPRING	3	
10	92901-06600-00	WASHER	3	
11	1M1-14714-00-00	GASKET, MUFFLER	1	
12	90460-43053-00	CLAMP, HOSE	2	
13	(2X7-14753-00-00)	SILENCER, EXHAUST	1	
14	2X8-14752-00-00	PIPE, OUTLET	1	
15	98580-06012-00	SCREW, PAN HEAD	2	
16	92995-06100-00	WASHER, SPRING	2	
17	95380-06600-00	NUT	2	
18	565-14747-00-00	DAMPER, MUFFLER	2	
19	90387-08258-00	COLLAR	2	
20	90201-08753-00	WASHER, PLATE	4	
21	97313-08035-00	BOLT, HEXAGON	2	
22	92990-08100-00	WASHER	2	
23	92990-08200-00	WASHER, PLAIN	2	
24	95303-08700-00	NUT	2	
25	1W6-14781-00-00	STAY, MUFFLER 2	1	
26	97313-08018-00	BOLT, HEXAGON (97301-08016)	2	
27	92990-08100-00	WASHER	2	
28	92901-08600-00	WASHER	2	
29	(2X7-14787-00-00)	CAP, SILENCER	1	

CONTINUED ON NEXT FRAME ►

EXHAUST

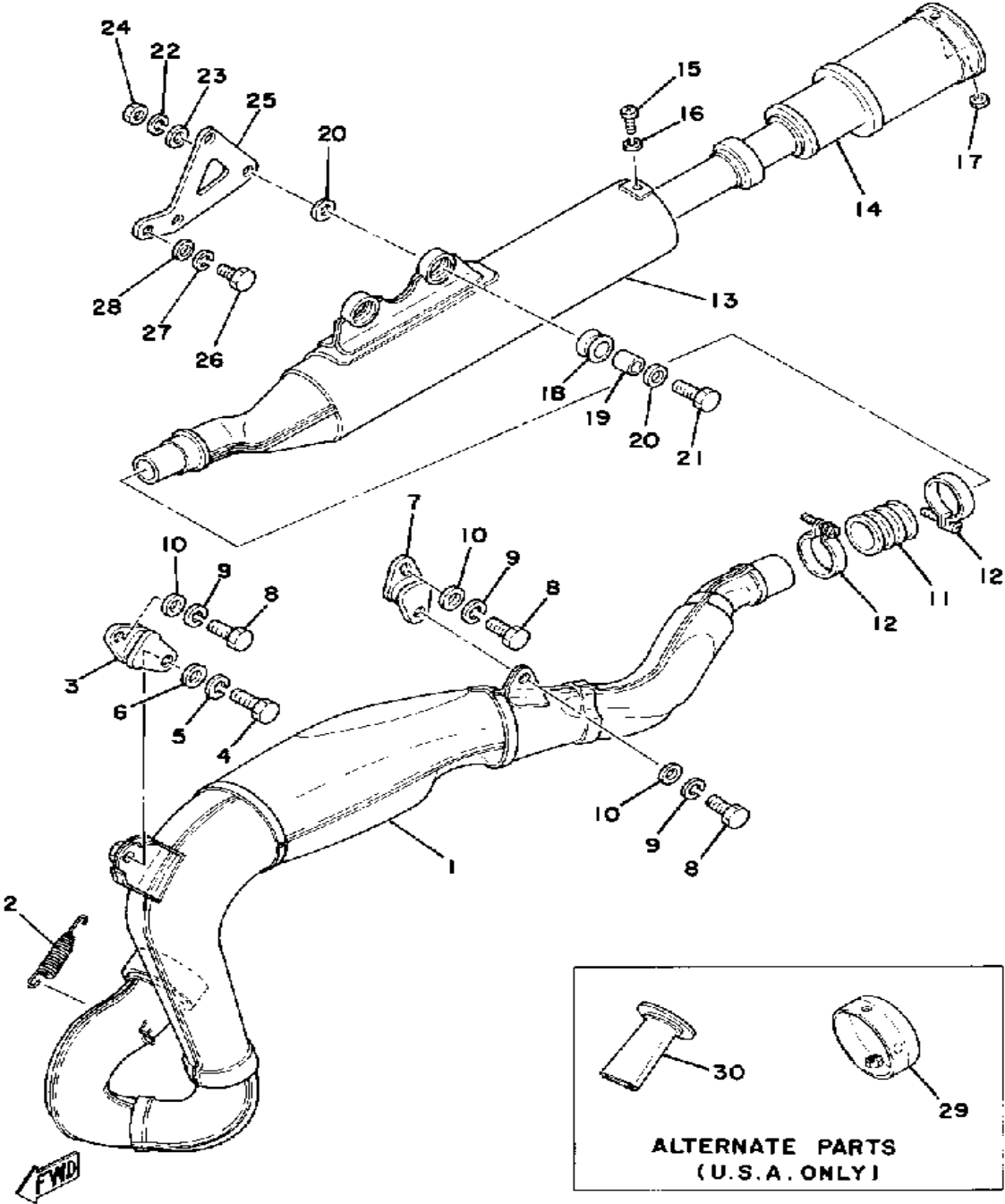

Ref. No.	Part Number	Description	Qty	Remarks
30	(2X8-14634-00-00)	PIPE, CHOKE	1	

SPECIAL SERVICE TOOLS
 90890-03097-00 DIAL INDICATOR (UNIVERSAL)
 90890-03098-00 DIAL INDICATOR EXTENSION TIP
 90890-01189-00 MAGNETO FLYWHEEL PULLER (UNIVERSAL)
 90890-01256-00 DIAL INDICATOR SPARK PLUG STAND, 14MM (UNIVERSAL)

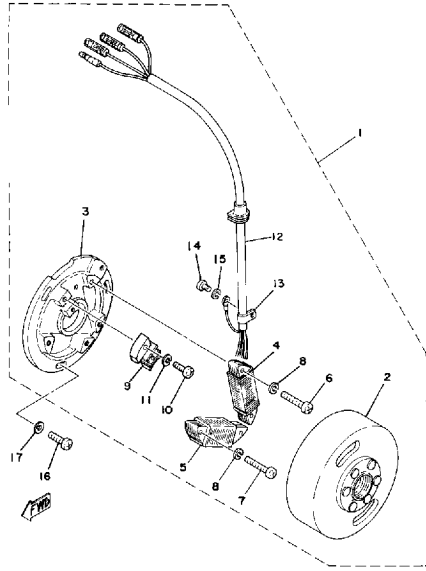

C - D - I MAGNETO

Ref. No.	Part Number	Description	Qty	Remarks
1	(2X8-85500-20-00)	CDI MAGNETO ASSEMBLY ...	1	
2	(2X9-85550-20-00)	ROTOR ASSEMBLY	1	
3	1M2-85509-20-00	. BASE, MAGNETO	1	
4	2X9-85512-20-00	. COIL SOURCE 2	1	
5	(1W6-85513-20-00)	COIL, LIGHTING 1	1	
6	98503-05025-00	. SCREW, PAN HEAD (98501-05025)	2	
7	98501-05018-00	. SCREW, PAN HEAD	2	
8	92990-05100-00	. WASHER, SPRING	4	
9	2X9-85580-20-00	. COIL, PULSER	1	
10	98506-04018-00	. SCREW, PAN HEAD	2	
11	92901-04100-00	. WASHER, SPRING	2	
12	(2X7-85515-20-00)	LEAD WIRE ASSEMBLY	1	
13	104-81328-20-00	. CLAMP	1	
14	98511-04006-00	. SCREW, PAN HEAD (98501-04005)	1	
15	92901-04100-00	. WASHER, SPRING	1	
16	98580-06020-00	SCREW	3	
17	92901-06600-00	WASHER	3	

FRAME-SIDE COVER

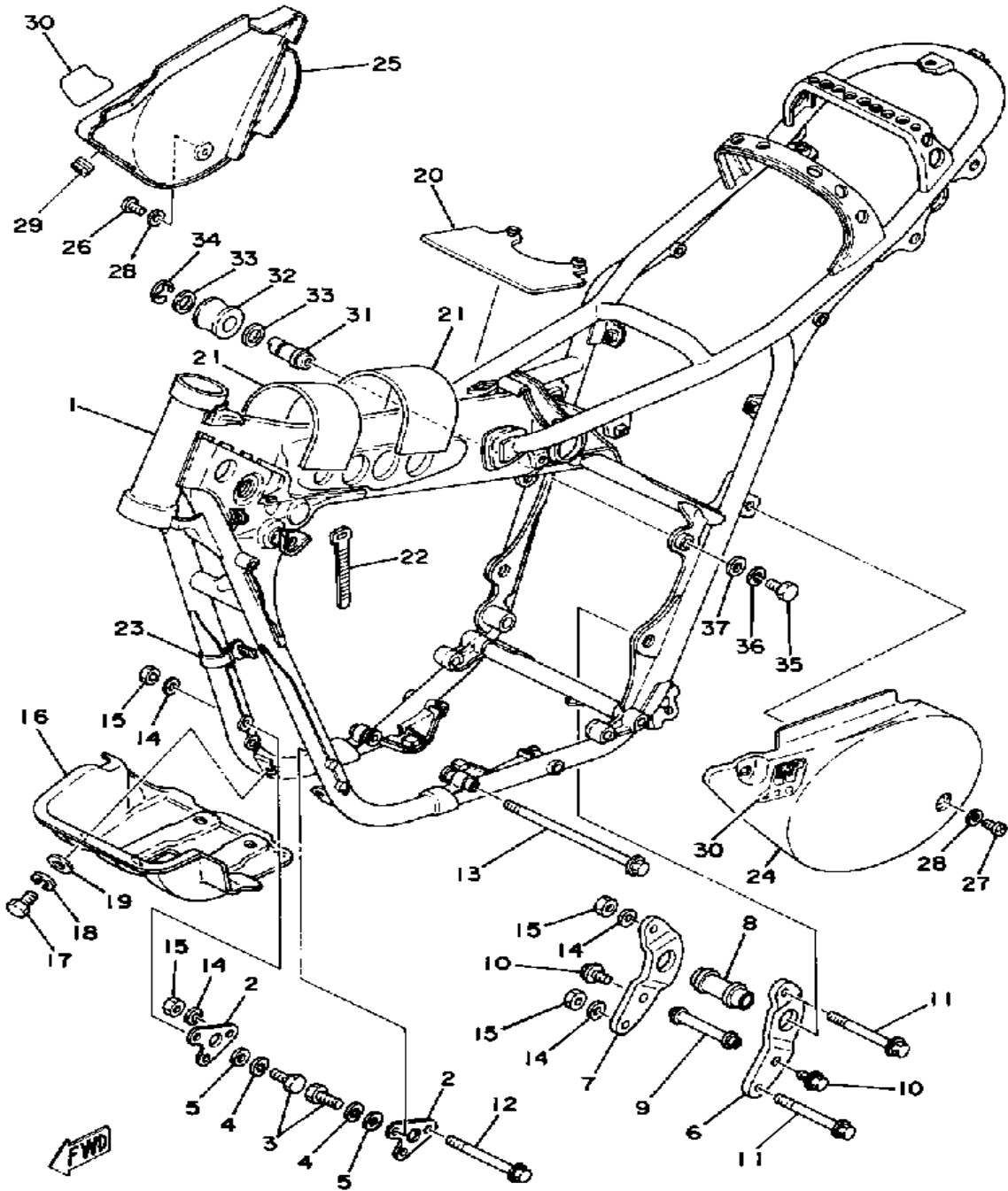

Ref. No.	Part Number	Description	Qty	Remarks
1	(2X7-21110-00-33)	FRAME	1	YAMAHA BLACK
2	2X4-21415-00-00	BRACKET, FRT UPR 1 (2K7-21415-00)	2	
3	97001-08025-00	BOLT (1NV)	4	
4	92990-08100-00	WASHER	4	
5	92901-08600-00	WASHER	4	
6	2K7-21427-00-00	BRACKET, REAR LWR 1	1	
7	(2K7-21428-00-00)	BRACKET, REAR LWR 2	1	
8	(2K7-21459-00-00)	SPACER	1	
9	(2K7-21424-00-00)	BOSS, ENGINE MOUNT	1	
10	95811-08016-00	BOLT, FLANGE	2	
11	95811-08090-00	BOLT, FLANGE (95822-08090) .	2	
12	95811-08100-00	BOLT	1	
13	95811-08180-00	BOLT, FLANGE	1	
14	92990-08200-00	WASHER, PLAIN	4	
15	90185-08089-00	NUT, SELF-LOCKING	4	
16	(2X7-21471-00-00)	PROTECTOR, ENGINE	1	
17	97313-08018-00	BOLT, HEXAGON (97301-08016)	4	
18	92990-08100-00	WASHER	4	
19	92901-08600-00	WASHER	4	
20	(1W1-24181-00-00)	DAMPER, LOCATING 1	1	
21	1W1-24183-00-00	DAMPER, LOCATING 3	2	
22	437-83936-01-00	BAND, SWITCH CORD	4	
23	437-83936-11-00	BAND, SWITCH CORD	1	
24	1W6-21711-00-26	COVER, SIDE 1	1	SKY BLUE/ COMP. YELLOW
25	1W6-21721-00-26	COVER, SIDE 2	1	SKY BLUE/COMP. YELLOW
26	98980-06016-00	SCREW, BINDING	1	
27	98903-06012-00	SCREW, BIND	2	

CONTINUED ON NEXT FRAME ➤

FRAME-SIDE COVER

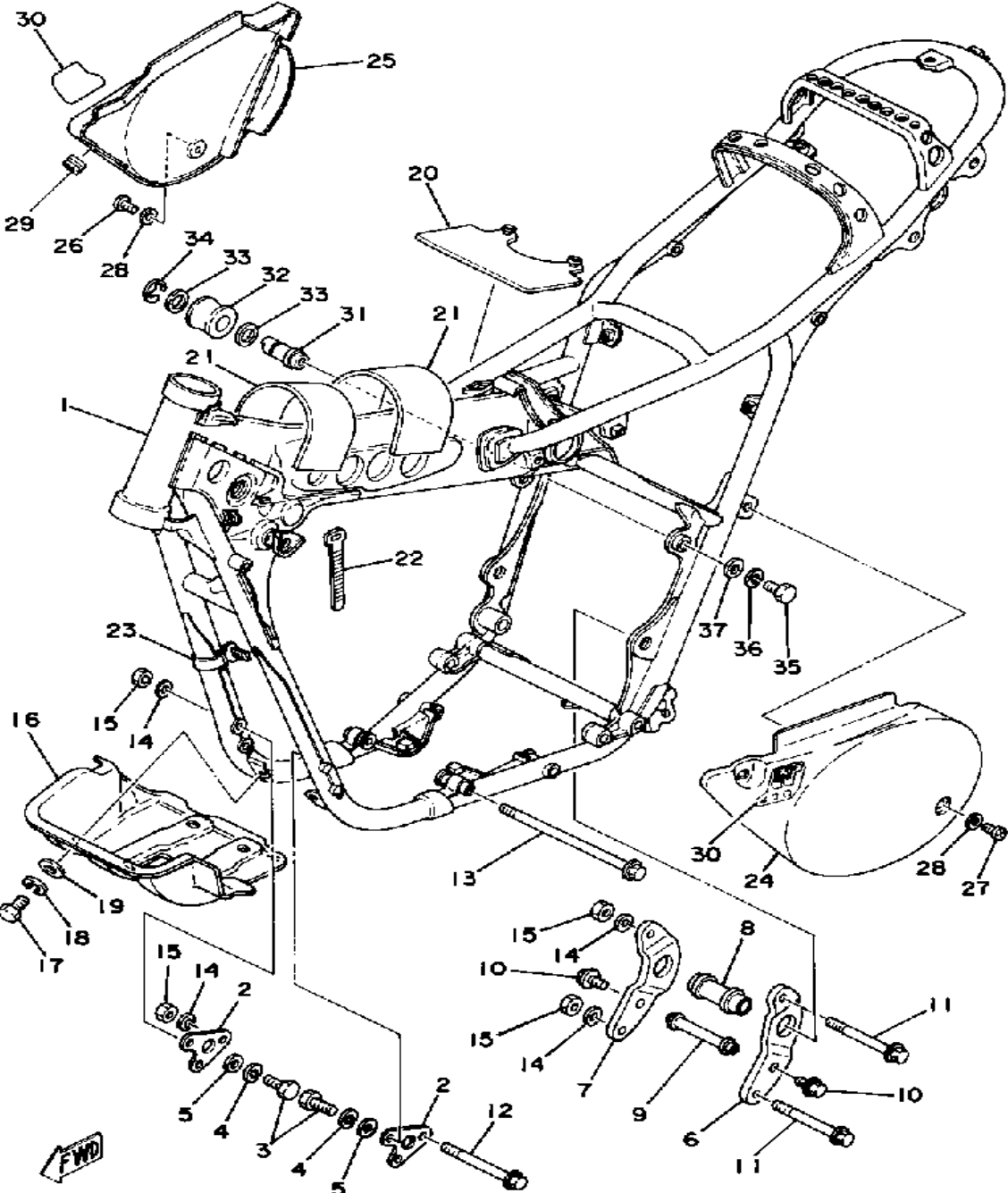

Ref. No.	Part Number	Description	Qty	Remarks
28	90201-06571-00	WASHER, PLATE	3	
29	90480-12053-00	GROMMET	1	
30	(2X8-21786-00-00)	EMBLEM 6	2	
31	2K6-2148A-02-00	SHAFT	1	
32	2K6-22178-00-00	TENSIONER	1	
33	90201-13202-00	WASHER, PLATE	2	
34	1W1-18136-00-00	CLIP, SHIFT SHAFT	1	
35	97313-08020-00	BOLT, HEXAGON	1	
36	92990-08100-00	WASHER	1	
37	(2X7-27000-00-00)	MAIN STAND KIT		
	92990-08200-00	WASHER, PLAIN	1	

REAR ARM-CHAIN CASE

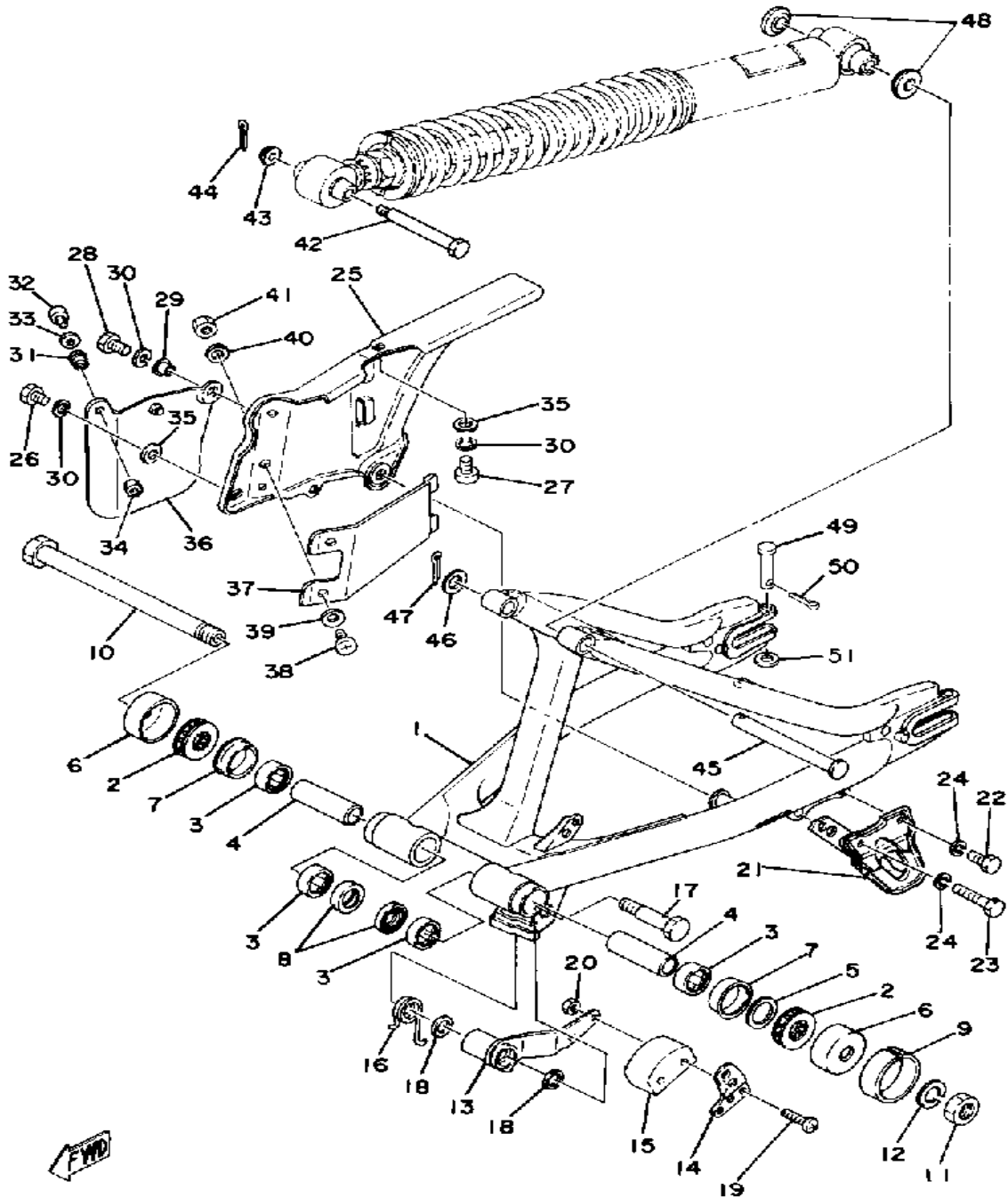

Ref. No.	Part Number	Description	Qty	Remarks
1	(2X7-22110-00-33)	REAR ARM	1	YAMAHA BLACK
2	93342-22205-00	BEARING, FLAT # 2	2	
3	93317-22214-00	BEARING, CYLINDER.# 7	4	
4	90380-16056-00	BUSH, SOLID	2	
5	648-45533-00-03	SHIM	1	
6	2X4-22129-00-00	COVER, THRUST 2	2	
7	93108-35004-00	OIL SEAL (35-41-8)	2	
8	93109-22018-00	OIL SEAL, SDO-TYPE	2	
9	431-22151-03-00	SEAL, GUARD	1	
10	1W4-22141-00-00	SHAFT, PIVOT	1	
11	90170-16111-00	NUT, HEXAGON	1	
12	92901-16100-00	WASHER, SPRING	1	
13	(1W6-22179-00-00)	ARM, TENSIONER	1	
14	1W1-22187-00-00	GUIDE, CHAIN	1	
15	ACC-11130-00-25	TENSIONER (2N0-22178-00-00)	1	
16	90508-35350-00	SPRING, TORSION	1	
17	90109-10483-00	BOLT (90109-10533-00)	1	
18	93104-14044-00	OIL SEAL	2	
19	98501-05035-00	SCREW, PAN HEAD	2	
20	95311-05700-00	NUT	2	
21	2W6-22153-00-00	GUARD, CHAIN	1	
22	97013-06012-00	BOLT	1	
23	97313-06055-00	BOLT, HEXAGON (97322-06055)	1	
24	92995-06100-00	WASHER, SPRING	2	
25	(2X7-22311-00-00)	CASE, CHAIN	1	
26	97301-06014-00	BOLT, HEXAGON	1	
27	98503-06014-00	SCREW, PAN HEAD (92502-06016)	1	
28	97011-06020-00	BOLT	1	

CONTINUED ON NEXT FRAME ►

REAR ARM-CHAIN CASE

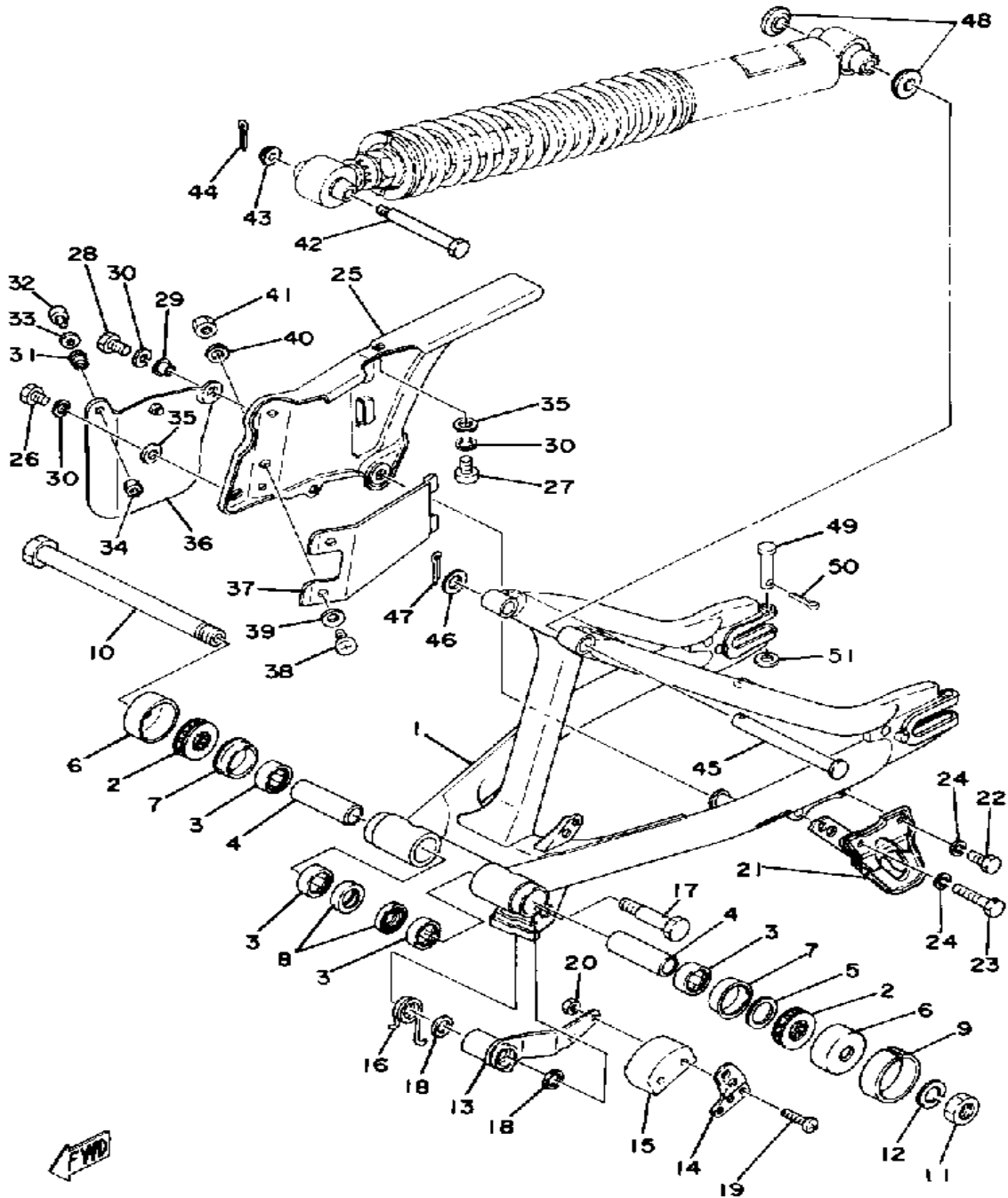

Ref. No.	Part Number	Description	Qty	Remarks
29	90387-06500-00	COLLAR	1	
30	92995-06100-00	WASHER, SPRING	3	
31	90387-062M9-00	COLLAR	1	
32	98503-06014-00	SCREW, PAN HEAD (92502-06016)	1	
33	92901-06600-00	WASHER	1	
34	95601-06100-00	NUT, U	1	
35	92901-06600-00	WASHER	2	
36	(2X7-22313-00-00)	RUBBER, CHAIN CASE	1	
37	(1W6-22318-00-00)	GUARD, CHAIN	1	
38	98580-05010-00	SCREW, PAN HEAD	2	
39	92901-05600-00	WASHER, PLATE	2	
40	92990-05200-00	WASHER, PLAIN	2	
41	95601-05100-00	NUT, U	2	
42	90109-08480-00	BOLT	1	
43	90179-08243-00	NUT, SPEC'L SHAPE	1	
44	91490-20020-00	PIN, COTTER	1	
45	90240-12060-00	PIN, CLEVIS	1	
46	92990-12600-00	WASHER, PLATE	1	
47	91401-30030-00	PIN, COTTER	1	
48	1W1-22128-00-00	COVER, THRUST 1	2	
49	91701-08042-00	PIN, CLEVIS	2	
50	91401-25020-00	PIN, COTTER	2	
51	92901-08600-00	WASHER	2	

REAR CUSHION

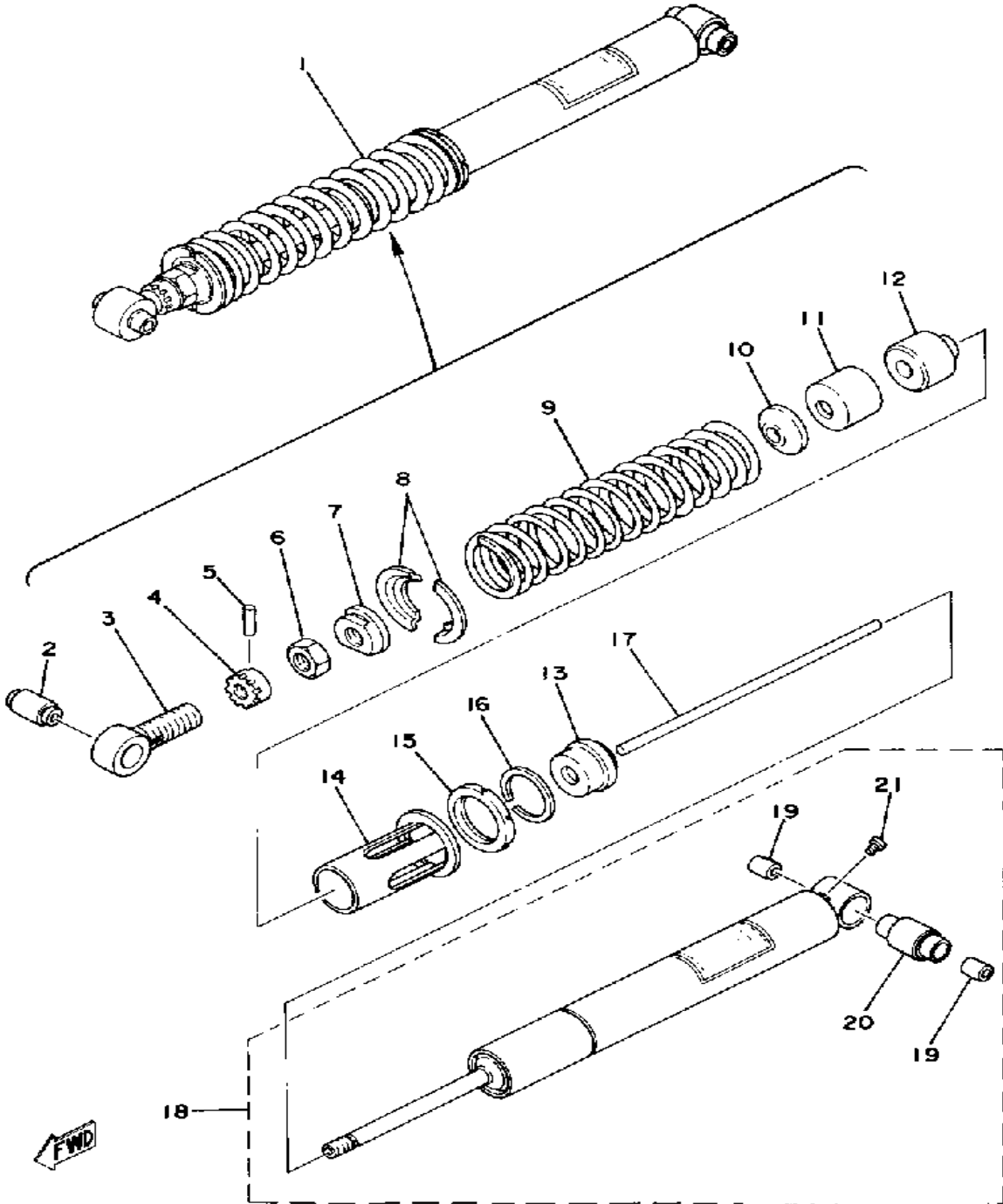

Ref. No.	Part Number	Description	Qty	Remarks
1	(2X7-22210-00-00)	SHK/ABS ASSEMBLY, REAR	1	
2	1YW-22216-00-00	. BUSH, RR SHOCK ABS	1	
3	(1W1-22219-00-00)	BRACKET, UPPER	1	
4	(1W1-22497-00-00)	NUT, ADJUSTING	1	
5	93604-26132-00	. PIN, DOWEL	1	
6	90170-20320-00	. NUT	1	
7	(2K6-22213-00-00)	SEAT, SPRING UPPER	1	
8	2K6-22214-00-00	. GUIDE, SPRING 1	2	
9	(90501-98538-00)	SPRING, COMPRESSION	1	SOFT
	(90501-99539-00)	SPRING, COMPRESSION	1	PAINTED BLUE
	(90501-99551-00)	SPRING, COMPRESSION	1	HARD 1
10	(2W6-22228-00-00)	SUPPORT, BUMP STOP	1	
11	(1W1-22221-00-00)	COVER	1	
12	(2W6-22493-00-00)	BUMP, STOP	1	
13	(1W1-22472-00-00)	CAP, CASE	1	
14	(1W1-22224-00-00)	GUIDE, SPRING 2	1	
15	(1W1-22223-00-00)	SEAT, SPRING LOWER	1	
16	(93440-50058-00)	CIRCLIP, OUTER	1	
17	(2W6-22489-00-00)	ROD, PUSH	1	
18	(2X7-22401-00-00)	DAMPER SUB-ASSEMBLY.	1	
19	90380-12051-00	.. BUSH, SOLID	2	
20	1W1-22226-00-00	. BUSH, SHOCK ABS LWR	1	
21	98511-04006-00	.. SCREW, PAN HEAD (98501-04005)	1	

STAND-FOOTREST-BRAKE PEDAL

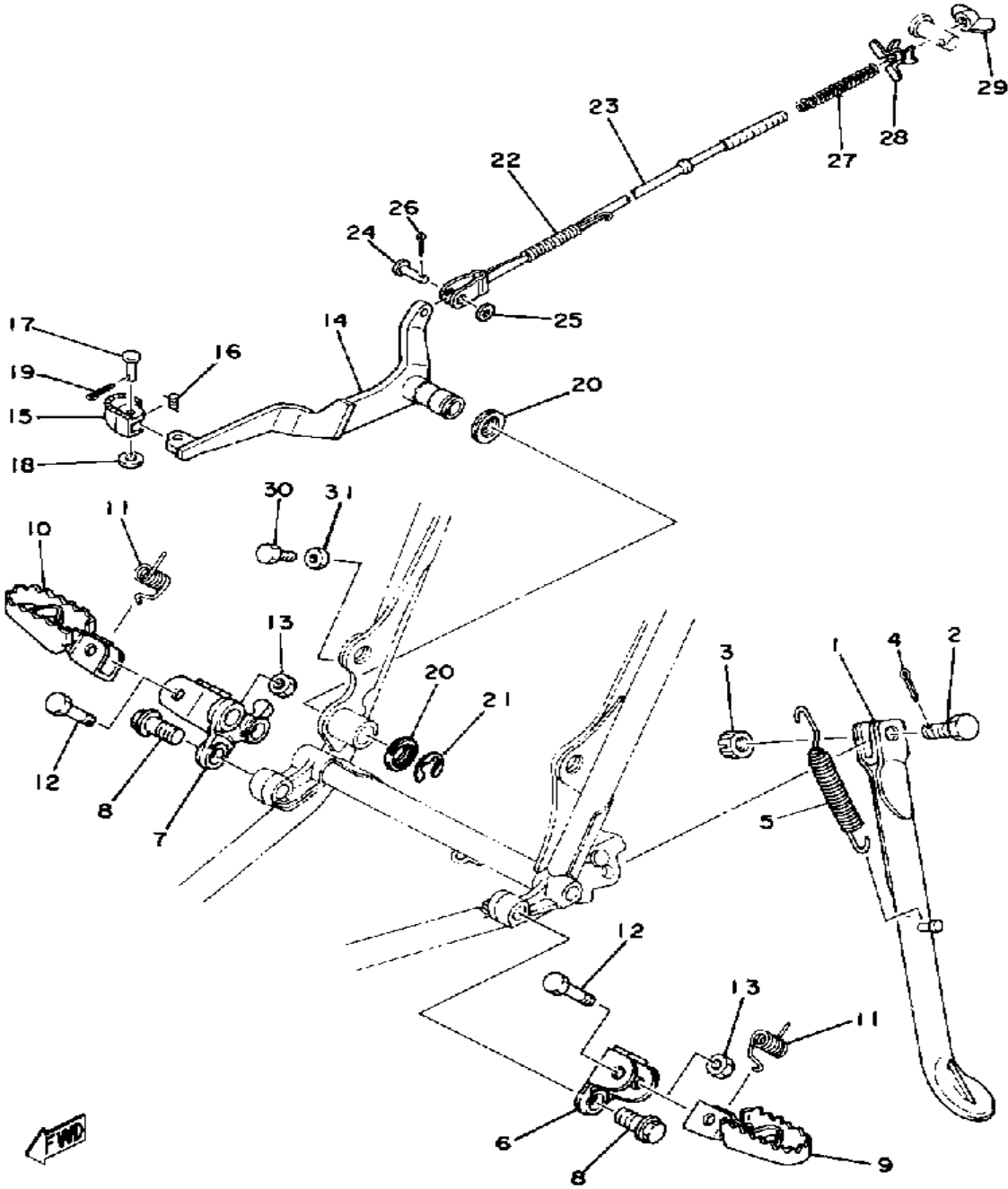

Ref. No.	Part Number	Description	Qty	Remarks
1	1W4-27311-00-00	STAND, SIDE	1	
2	90102-10006-00	BOLT, WITH HOLE (278-27317-00)	1	
3	95303-10900-00	NUT, SLOTTED	1	
4	91490-20025-00	PIN, SPLIT	1	
5	90507-29008-00	SPRING, TENSION	1	
6	2X4-27412-00-00	BRACKET, FOOTREST 1	1	
7	(2X7-27422-00-00)	BRACKET, FOOTREST 2	1	
8	90105-12096-00	BOLT, WASHER BASED	4	
9	3R4-27411-00-00	FOOTREST 1	1	
10	3R4-27421-00-00	FOOTREST 2	1	
11	90508-20023-00	SPRING, TORSION	2	
12	90101-08428-00	BOLT	2	
13	95611-08100-00	NUT, U	2	
14	2X7-27211-00-00	PEDAL, BRAKE	1	
15	55V-27242-00-00	PEDAL, BRAKE	1	
16	90508-14352-00	SPRING, TORSION	1	
17	91701-06022-00	PIN, CLEVIS	1	
18	92901-06600-00	WASHER	1	
19	91490-20020-00	PIN, COTTER	1	
20	498-27235-00-00	COVER, DUST	2	
21	99001-15600-00	CIRCLIP, E-TYPE	1	
22	90506-20128-00	SPRING, TENSION	1	
23	2K5-27231-00-00	ROD, BRAKE	1	
24	90240-06103-00	PIN, CLEVIS	1	
25	92990-06200-00	WASHER	1	
26	91490-20020-00	PIN, COTTER	1	
27	90501-10245-00	SPRING, COMPRESSION	1	
28	1W2-27239-00-00	SEAT, SPRING	1	

CONTINUED ON NEXT FRAME ►

STAND-FOOTREST-BRAKE PEDAL

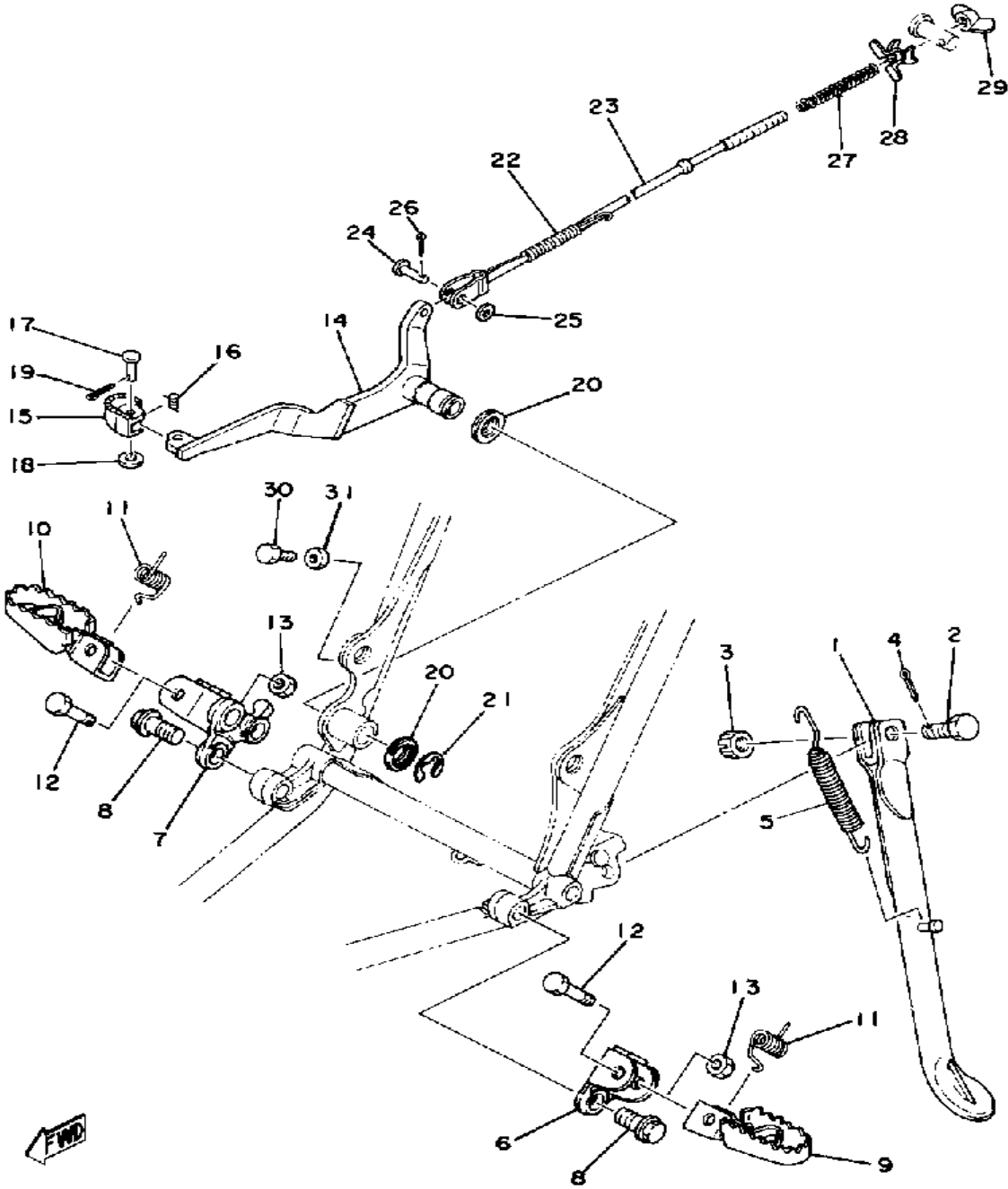

Ref. No.	Part Number	Description	Qty	Remarks
29	90179-06411-00	NUT	1	
30	97011-06020-00	BOLT	1	
31	95380-06700-00	NUT	1	

FRONT FENDER-REAR FENDER

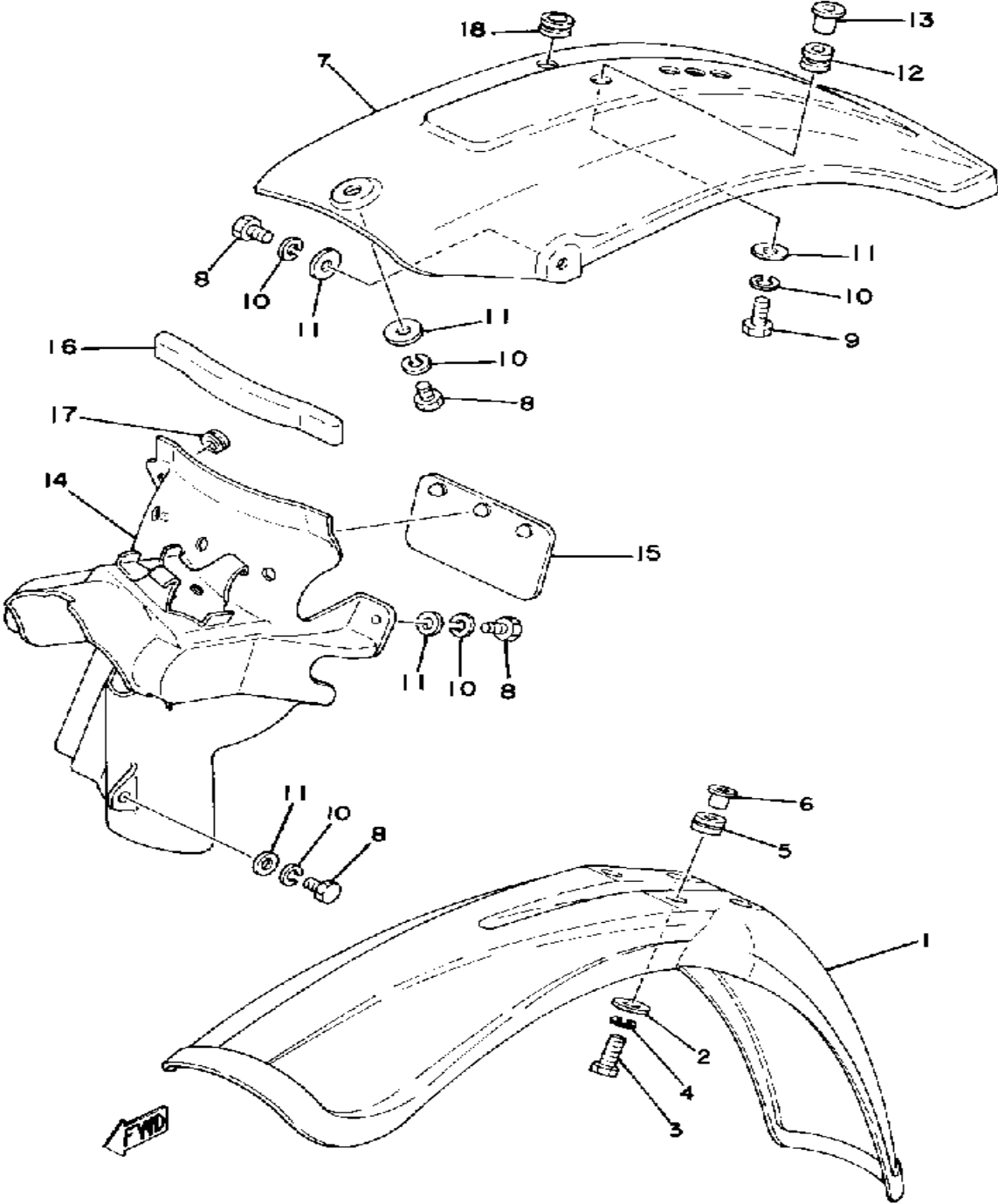

Ref. No.	Part Number	Description	Qty	Remarks
1	99999-02158-00	FENDER, FRONT SET	1	SKY BLUE
2	90201-06067-00	WASHER, PLATE	4	
3	97011-06025-00	BOLT (97001-06025)	4	
4	92995-06100-00	WASHER, SPRING	4	
5	90480-14198-00	GROMMET	4	
6	90387-07391-00	COLLAR	4	
7	1W2-21611-00-00	FENDER, REAR	1	SKY BLUE
8	97301-06014-00	BOLT, HEXAGON	6	
9	97011-06025-00	BOLT (97001-06025)	1	
10	92995-06100-00	WASHER, SPRING	7	
11	90201-06067-00	WASHER, PLATE	7	
12	90480-14198-00	GROMMET	1	
13	90387-06388-00	COLLAR	1	
14	(2K7-21620-00-00)	GUARD, MUD	1	
15	1M1-21621-00-00	FLAP	1	
16	565-21746-00-00	DAMPER	1	
17	90480-13018-00	GROMMET	1	
18	90480-15058-00	GROMMET	1	

FRONT FORK

SPECIAL SERVICE TOOLS
90890-01051-00 STEERING NUT WRENCH

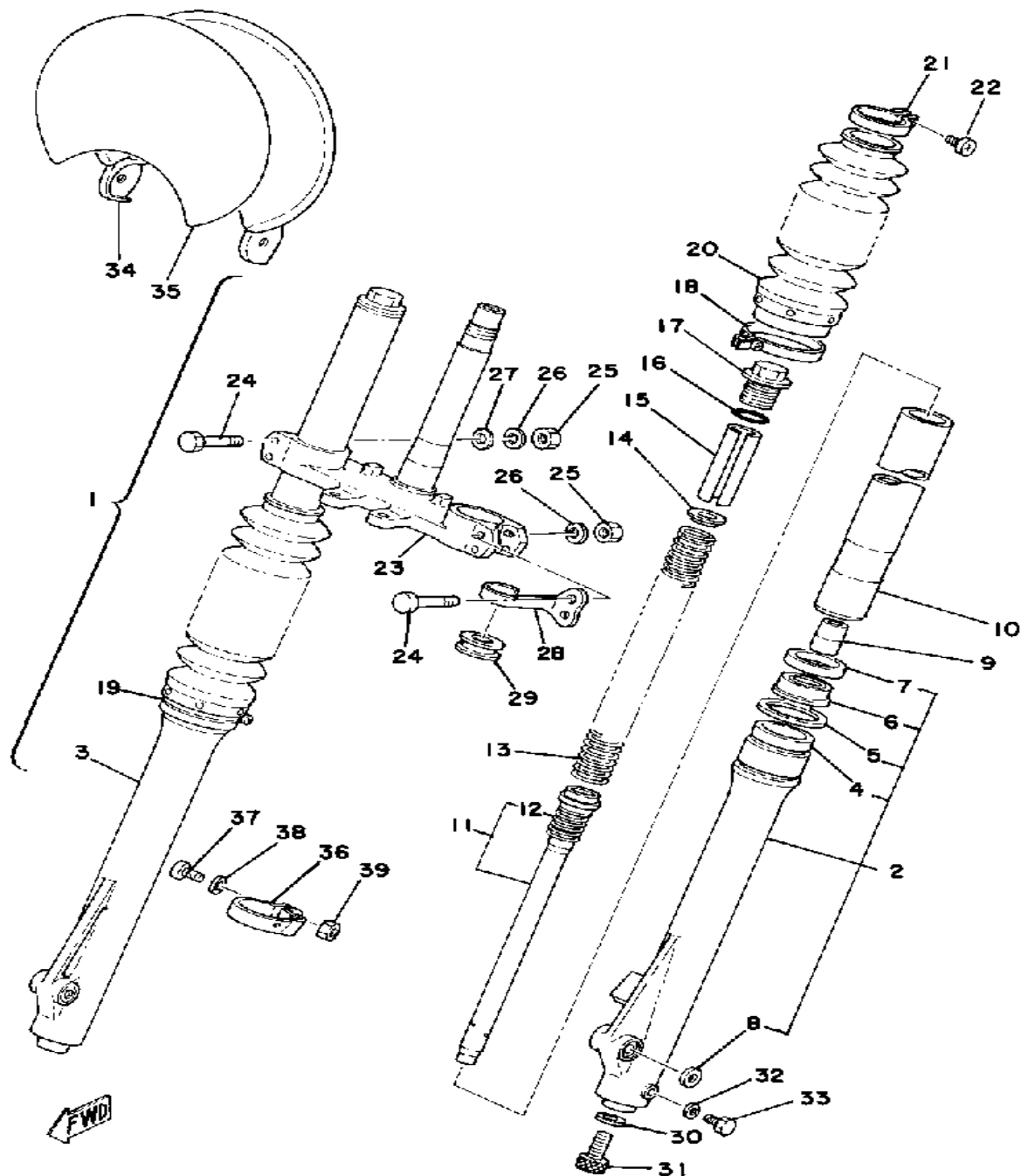

Ref. No.	Part Number	Description	Qty	Remarks
1	(2X7-23101-00-00)	FRONT FORK ASSEMBLY	1	
2	(1W2-23126-01-00)	TUBE, OUTER 1	1	
3	(1W2-23136-01-00)	TUBE, OUTER 2	1	
4	48Y-23145-00-00	.. OIL SEAL	2	
5	1W1-23156-L0-00	.. CLIP, OIL SEAL	2	
6	1G8-23144-L1-00	.. SEAL, DUST	2	
7	99999-01510-00	.. COVER, DUST SEAL	2	
8	1W1-23168-L0-00	.. CAP, FRONT FORK	2	
9	1W1-23173-L0-00	. SPINDLE, TAPER	2	
10	(2X7-23110-00-00)	INNER TUBE 1	2	
11	(2X7-23170-00-00)	CYLINDER, FRTFRK	2	
12	2X7-23151-00-00	.. SPRING, REBOUND	2	
13	(2X7-23141-00-00)	SPRING, FRONT FORK	2	
	(2X7-23141-10-00)	SPRING, FRONT FORK	2	3 W/SET
	(2X7-23141-20-00)	SPRING, FRONT FORK	2	
14	1W1-23142-L0-00	. SEAT, SPRING UPPER	2	
15	(1W1-23118-L0-00)	SPACER	2	
	38V-23118-01-00	. SPACER	2	
16	1W1-23114-L0-00	. GASKET	2	
17	2X7-23111-00-00	. BOLT, CAP	2	
18	1W1-23318-L0-00	. HOLDER, CABLE 1	1	
19	509-23489-L0-00	. BAND	1	
20	(1W1-23191-L0-00)	BOOT, FRONT FORK	2	
21	341-92090-60-00	. BAND, BOOT	2	
22	509-23194-L0-00	. SCREW, BOOT BAND	2	
23	(2X7-23340-00-33)	UNDER BRACKET	1	
24	90101-08340-00	. BOLT	4	
25	95333-08600-00	. NUT	4	
26	92990-08100-00	. WASHER	4	

CONTINUED ON NEXT FRAME ►

FRONT FORK

SPECIAL SERVICE TOOLS
 90890-01051-00 STEERING NUT WRENCH

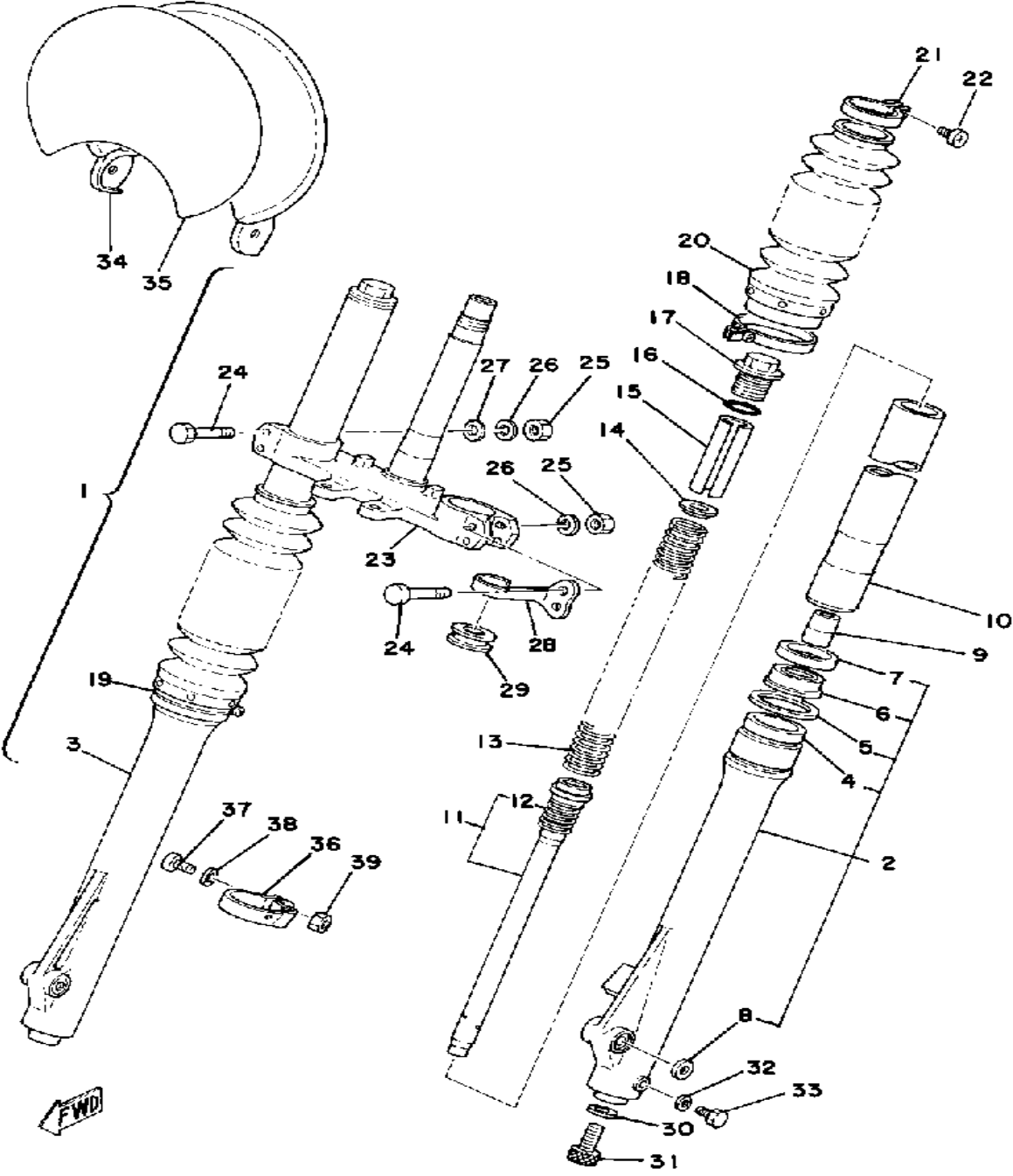

Ref. No.	Part Number	Description	Qty	Remarks
27	92901-08600-00	. WASHER	2	
28	1W1-23317-01-00	. HOLDER, CABLE	1	
29	1W1-23389-00-00	. GUIDE, CABLE	1	
30	509-23158-L0-00	. GASKET	2	
31	278-23181-50-00	. BOLT, HEXAGON SOCKET HEAD	2	
32	122-23129-00-00	. GASKET, DRAIN PLUG	2	
33	4H7-23119-00-00	. PLUG, DRAIN - (122-23119-01)	2	
	98580-04008-00	. SCREW, PAN HEAD	2	
34	1W2-23485-00-00	PLATE, NUMBER	1	
35	1W2-23395-00-00	EMBLEM	1	
36	1W2-23318-00-00	HOLDER, CABLE 1	1	
37	98501-05018-00	SCREW, PAN HEAD	1	
38	92901-05600-00	WASHER, PLATE	1	
39	95380-05600-00	NUT	1	

STEERING

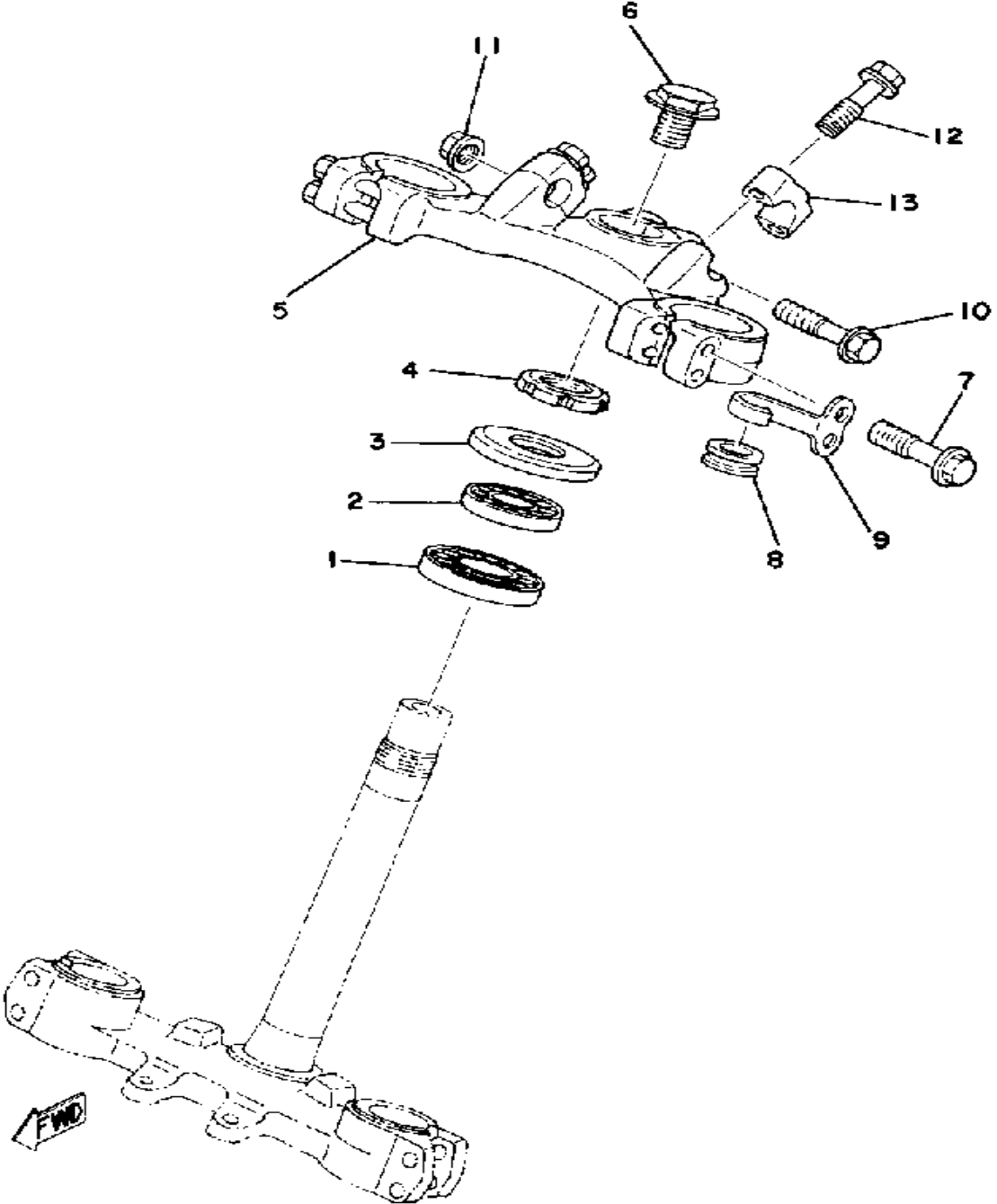

Ref. No.	Part Number	Description	Qty	Remarks
1	93332-00008-00	BEARING	1	
2	93332-00001-00	BEARING	1	
3	3HE-23416-00-00	COVER, BALL RACE 2	1	
4	90179-25033-00	NUT	1	
5	5X3-23435-01-98	CROWN, HANDLE	1	LOW GLOSS BLK
6	90105-14136-00	BOLT, WASHER BASED	1	
7	90105-08091-00	BOLT, WASHER BASED	4	
8	1W1-23389-00-00	GUIDE, CABLE	1	
9	1W1-23317-01-00	HOLDER, CABLE	1	
10	95811-08055-00	BOLT, FLANGE	1	
11	95701-08500-00	NUT, FLANGE	1	
12	95811-08035-00	BOLT, FLANGE (95821-08035) .	4	
13	1E6-23441-00-00	HOLDER, HANDLE UPR	2	LOW GLOSS BLK

HANDLE-WIRE

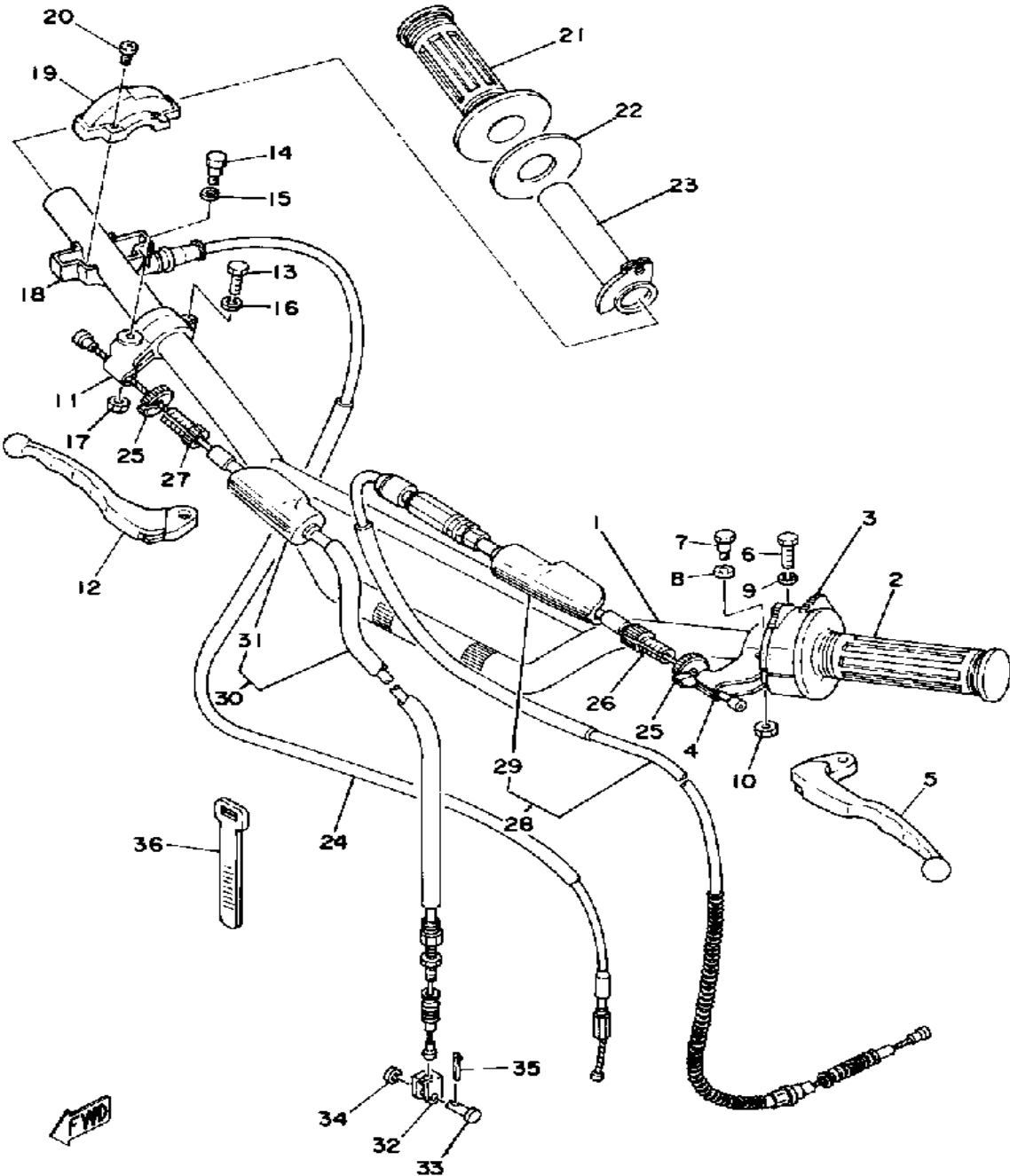

Ref. No.	Part Number	Description	Qty	Remarks
1	1W1-26111-03-00	HANDLEBAR (1W1-26111-02)	1	LOW GLOSS BLK
2	1E6-26241-00-00	GRIP LH	1	
3	1W2-83973-00-98	SWITCH, HANDLE 3	1	LOW GLOSS BLK
4	214-82911-01-00	HOLDER, LEVER 1	1	LOW GLOSS BLK
5	23X-83912-00-00	LEVER 1	1	
6	97003-06022-00	BOLT, HEXAGON (97301-06022)	1	
7	90109-06797-00	BOLT	1	
8	90201-08083-00	WASHER, PLATE	1	
9	92995-06100-00	WASHER, SPRING	1	
10	95601-06100-00	NUT, U	1	
11	516-82921-30-00	HOLDER, LEVER 2	1	LOW GLOSS BLK
12	23X-83922-00-00	LEVER 2	1	
13	97003-06022-00	BOLT, HEXAGON (97301-06022)	1	
14	90109-06797-00	BOLT	1	
15	90201-08083-00	WASHER, PLATE	1	
16	92995-06100-00	WASHER, SPRING	1	
17	95601-06100-00	NUT, U	1	
18	322-26281-00-98	CAP, GRIP UPPER	1	
19	322-26282-00-00	CAP, GRIP LOWER	1	
20	98580-05016-00	SCREW, PAN HEAD	2	
21	583-26242-00-00	GRIP RH	1	
22	1W1-26249-00-00	RING, leaf	1	
23	322-26243-00-00	TUBE, throttle guide	1	
24	1W6-26311-01-00	CABLE, THROTTLE 1	1	
25	90179-08148-00	NUT	2	
26	90123-08013-00	BOLT	1	
27	90123-08046-00	BOLT	1	
28	2K7-26335-00-00	CABLE, CLUTCH (1150MM)	1	
29	382-26372-01-00	. COVER, HANDLE LEVER	1	

CONTINUED ON NEXT FRAME ➤

HANDLE-WIRE

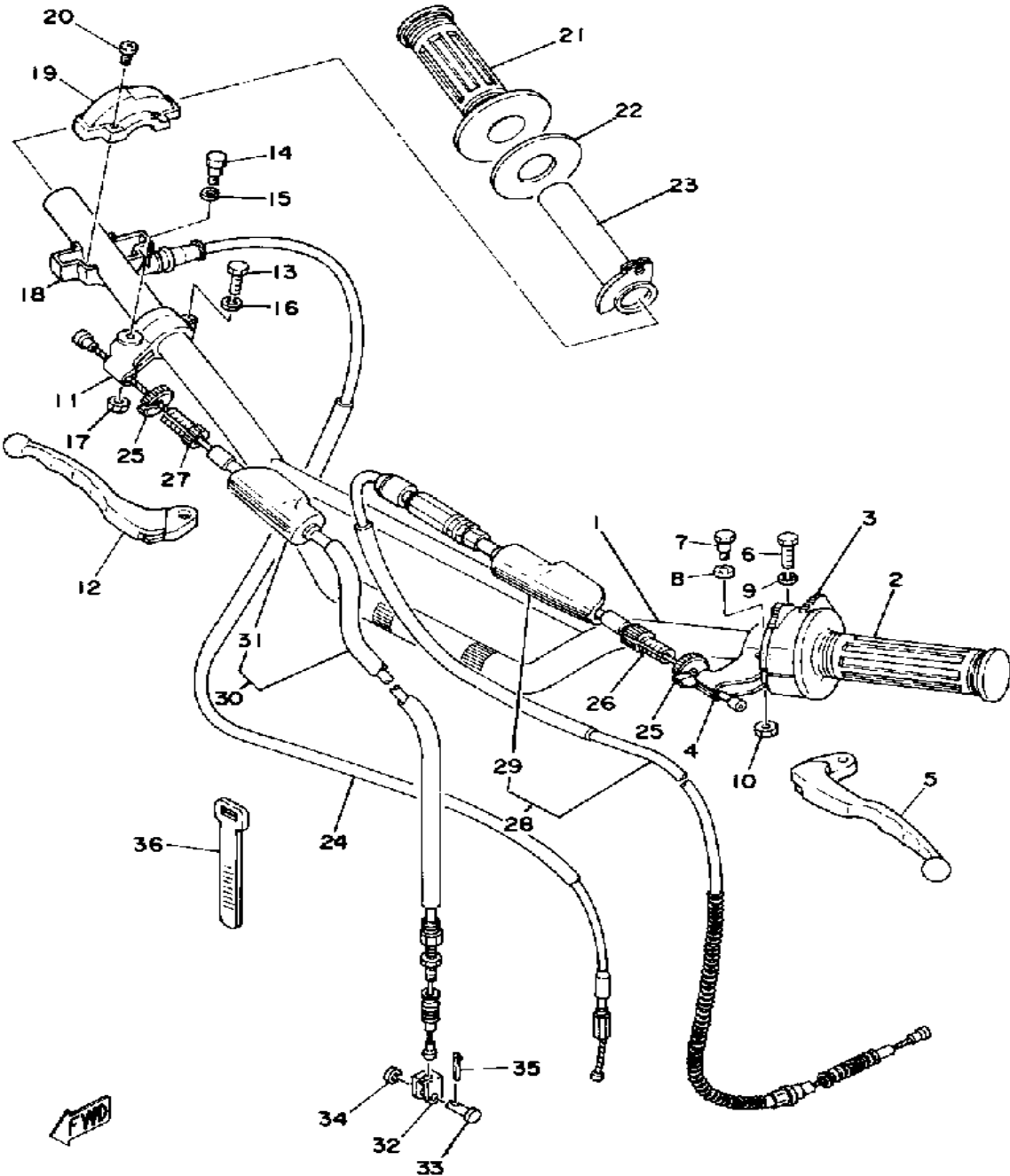

Ref. No.	Part Number	Description	Qty	Remarks
30	1W4-26341-02-00	CABLE, BRAKE (1230MM)	1	
31	382-26372-01-00	. COVER, HANDLE LEVER	1	
32	156-26347-00-00	JOINT, CABLE	1	
33	90240-08013-00	PIN, CLEVIS	1	
34	90201-08083-00	WASHER, PLATE	1	
35	91490-20020-00	PIN, COTTER	1	
36	437-83936-01-00	BAND, SWITCH CORD	2	

FUEL TANK

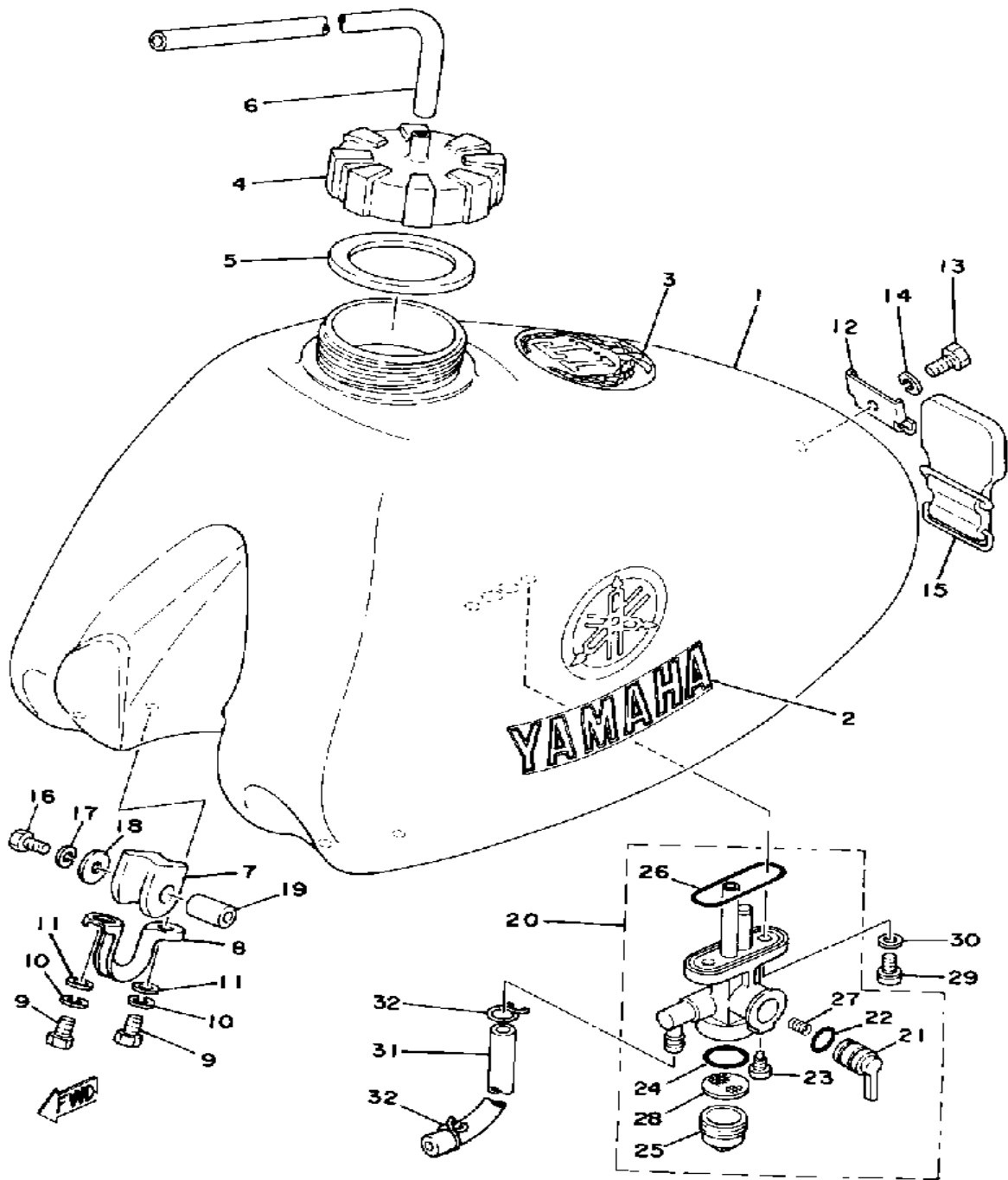

Ref. No.	Part Number	Description	Qty	Remarks
1	1W6-24110-00-00	FUEL TANK	1	SKY BLUE
2	(2W6-24161-00-00)	EMBLEM 1	2	
3	(1W2-24162-00-00)	EMBLEM 2	1	
4	1K7-24611-01-00	BODY, CAP	1	
5	1K7-24612-02-00	GASKET, CAP	1	
6	90445-09361-00	HOSE	1	
7	1W1-24182-01-00	DAMPER, LOCATING 2	2	
8	1W1-24144-01-00	HOLDER, DAMPER	2	
9	97013-06012-00	BOLT	4	
10	92995-06100-00	WASHER, SPRING	4	
11	92901-06600-00	WASHER	4	
12	1W1-24192-00-00	BRACKET, FUEL TNK 2	1	
13	97013-06012-00	BOLT	1	
14	92995-06100-00	WASHER, SPRING	1	
15	1W1-24173-00-00	BAND, TNK FITTING 1	1	
16	97013-06035-00	BOLT	2	
17	92995-06100-00	WASHER, SPRING	2	
18	90201-06407-00	WASHER, PLATE (90201-06747-00)	2	
19	90387-07393-00	COLLAR (308-84557-00)	2	
20	3R9-24500-00-00	FUEL COCK ASSEMBLY 1	1	
21	(2W6-24524-00-00)	LEVER, COCK	1	
22	2N3-24528-00-00	. GASKET	1	
23	2N3-24535-00-00	. SCREW, LVR FITTING	2	
24	357-24522-10-00	. GASKET	1	
25	(357-24521-10-00)	CUP, FILTER	1	
26	2W6-24512-00-00	. O-RING	1	
27	2W6-24529-00-00	. SPRING	1	
28	2W6-24561-00-00	. NET, FILTER	1	

CONTINUED ON NEXT FRAME ►

FUEL TANK

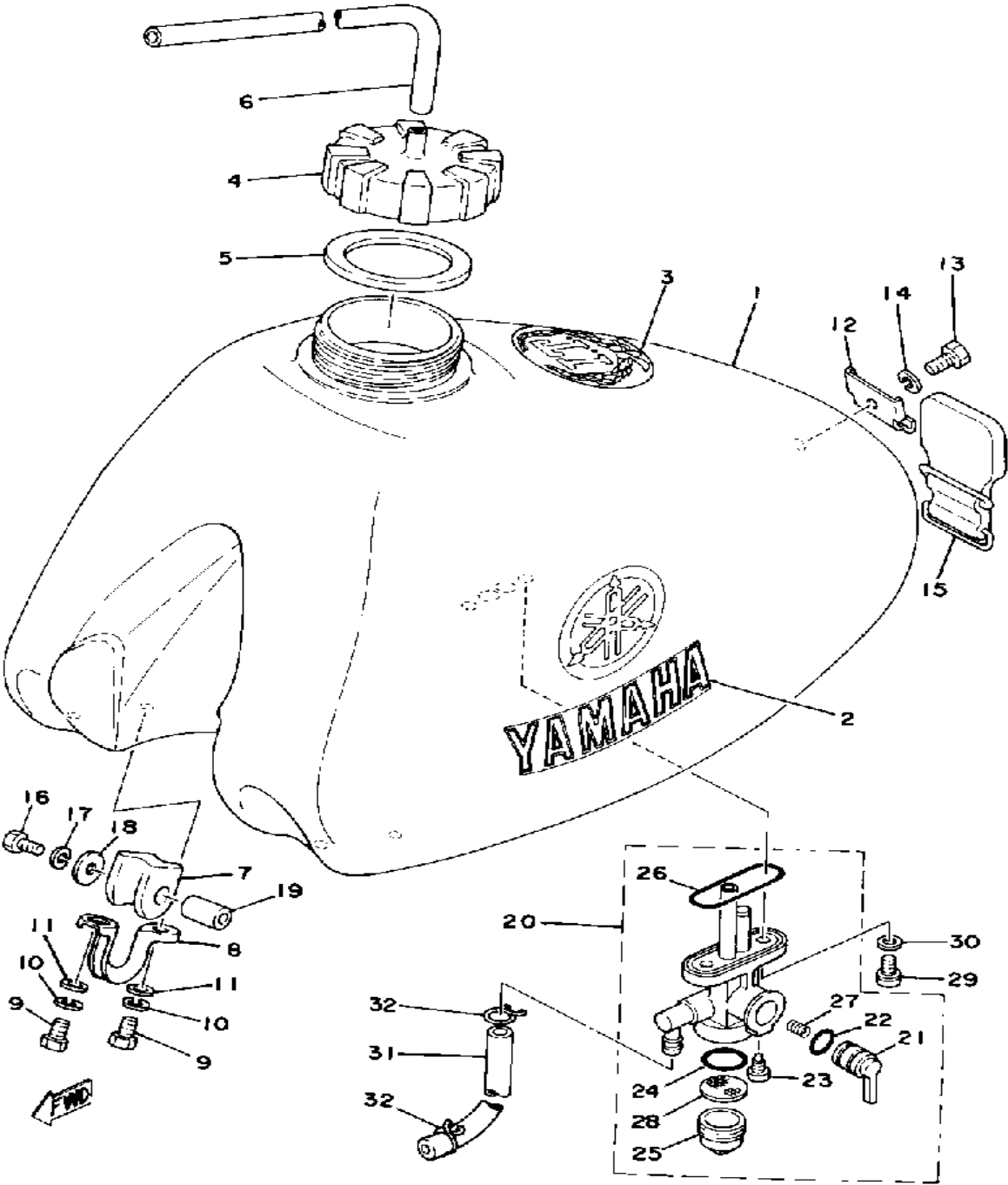

Ref. No.	Part Number	Description	Qty	Remarks
29	90149-06011-00	SCREW	2	
30	90202-05187-00	WASHER, PLATE	2	
31	90445-11182-00	HOSE	1	
32	90467-10008-00	CLIP	2	

SEAT

Ref. No.	Part Number	Description	Qty	Remarks
1	(2X7-W2473-00-00)	SEMI-DBL-SEAT ASSEMBLY ..	1	
2	2K8-24771-00-00	. COVER, SM-DBL SEAT	1	
3	97013-06035-00	BOLT	2	
4	92990-06200-00	WASHER	2	
5	95601-06100-00	NUT, U	2	
6	1M1-24748-00-00	BRACKET, SEAT	1	
7	1W1-24738-00-00	BRACKET, SEAT	2	
8	90101-06304-00	BOLT	6	
9	509-24724-00-00	DAMPER, SEAT	6	
10	1W2-24850-01-00	CARRIER BOX ASSEMBLY ...	1	
11	1W2-24833-01-00	BRACKET, CARRIER 2	1	
12	97001-06018-00	BOLT	3	
13	92995-06100-00	WASHER, SPRING	3	
14	90201-06067-00	WASHER, PLATE	3	
15	1W2-W2810-00-00	TOOL KIT	1	
16	10V-28135-00-00	. SPANNER, SPECIAL	1	

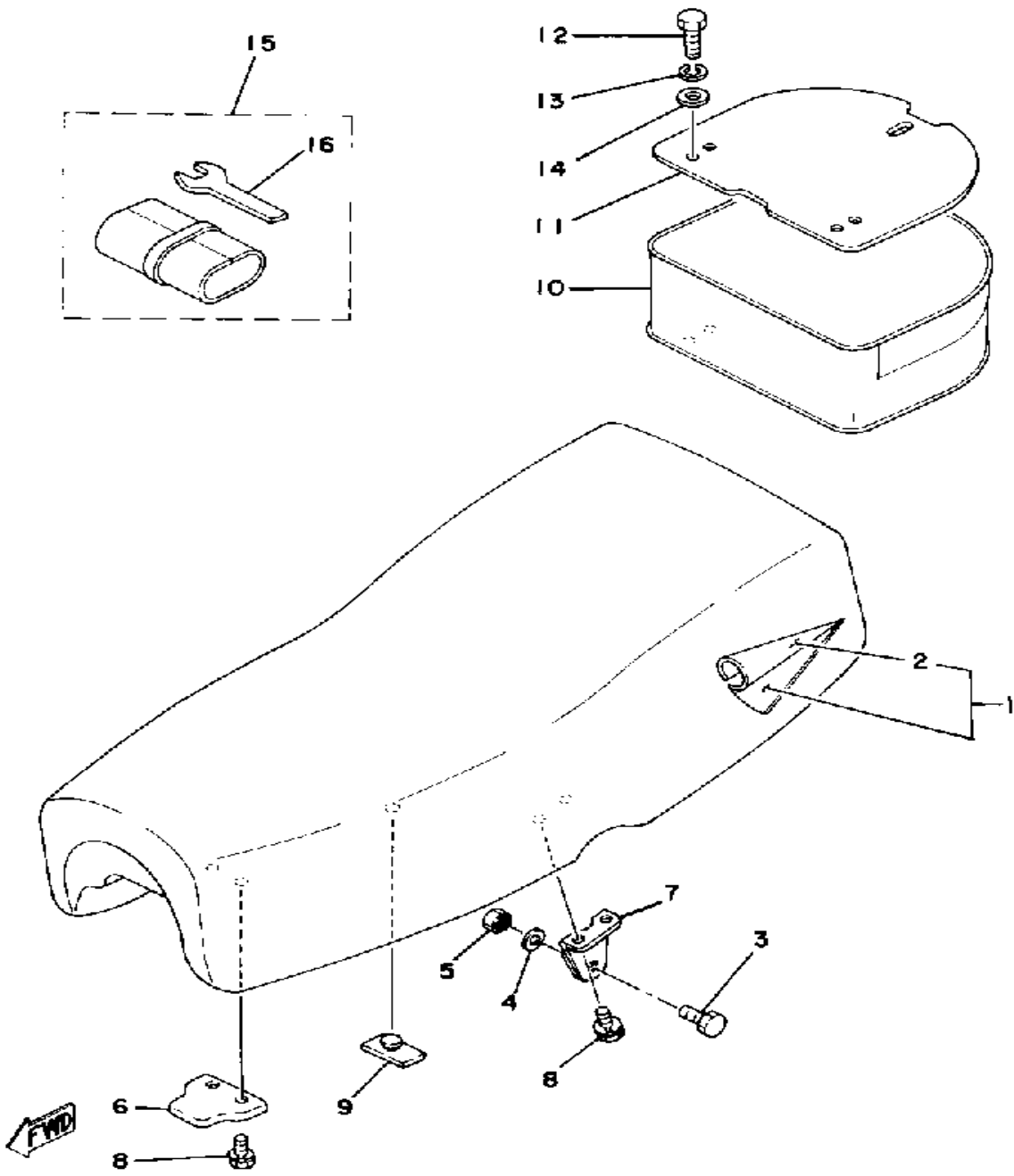

FRONT WHEEL

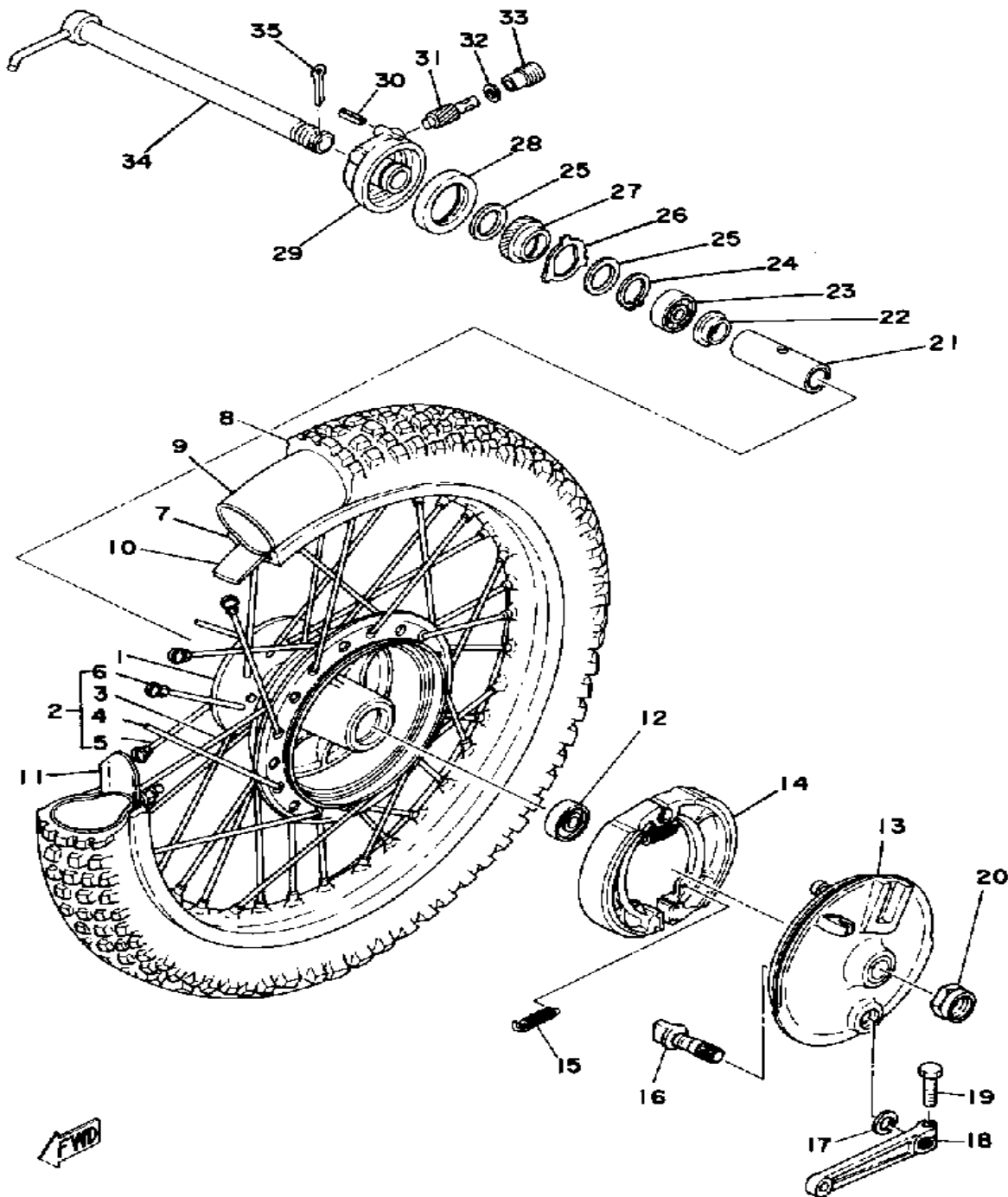

Ref. No.	Part Number	Description	Qty	Remarks
1	1K7-25111-10-98	HUB, FRONT	1	LOW GLOSS BLK
2	2W6-25104-02-00	SPOKE SET, FRONT	1	
3	(2W6-25196-90-00)	SPOKE SET, INNER 1	1	
4	(2W6-25197-90-00)	SPOKE SET, OUTER 1	1	
5	(2W6-25179-90-00)	SPOKE SET, INNER 2	1	
6	(2W6-25189-90-00)	SPOKE SET, OUTER 2	1	
7	94416-21326-00	RIM 1.60X 1	1	
8	(94130-213A4-00)	300-21 M1B (TT)	1	
9	94230-21126-00	TUBE (3.00-21)	1	
10	(94330-21088-00)	BAND, RIM	1	
11	1T1-25194-00-00	SPACER, BEAD	1	
12	93306-20226-00	BEARING	1	
13	1W1-25016-11-98	BRAKE SHOE PLT ASSEMBLY (1W1-25121-02-98)	1	LOW GLOSS BLK
14	322-W2535-00-00	BRAKESHOE SET-2PCS	2	
15	90506-17328-00	SPRING, TENSION	2	
16	23X-25151-00-00	CAMSHAFT	1	
17	137-25159-00-00	SEAL, CAMSHAFT	1	
18	322-25155-00-00	LEVER, CAMSHAFT 1	1	
19	90101-06291-00	BOLT	1	
20	90171-14020-00	NUT, CASTLE	1	
21	90560-15116-00	SPACER	1	
22	146-25116-00-00	FLANGE, SPACER 2	1	
23	93306-20209-00	BEARING (B6202)	1	
24	93410-22014-00	CIRCLIP, S-TYPE	1	
25	90201-22283-00	WASHER, PLATE	2	
26	1K7-25149-00-00	CLUTCH, METER	1	
27	1W2-25135-00-00	GEAR, DRIVE	1	
28	93106-40027-00	OIL SEAL	1	

CONTINUED ON NEXT FRAME ►

FRONT WHEEL

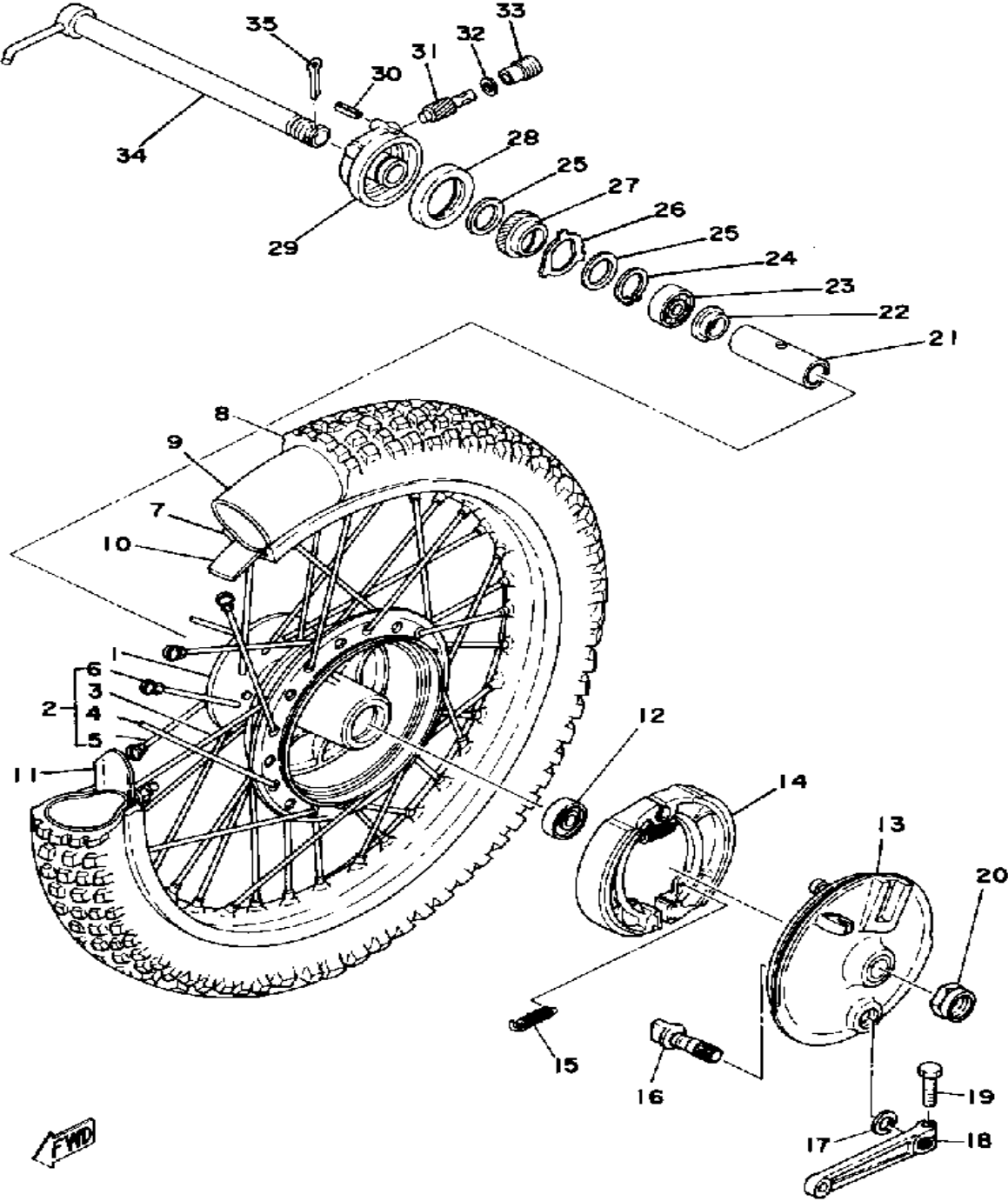

Ref. No.	Part Number	Description	Qty	Remarks
29	1W2-25190-00-00	GEAR UNIT ASSEMBLY	1	
30	91609-20014-00	PIN, SPRING	1	
31	1W2-25138-00-00	GEAR, METER	1	
32	102-18416-00-00	SHIM, ROD	1	
33	306-25136-00-00	BUSH	1	
34	1W2-25181-02-00	AXLE, WHEEL	1	
35	91401-30030-00	PIN, COTTER	1	

REAR WHEEL

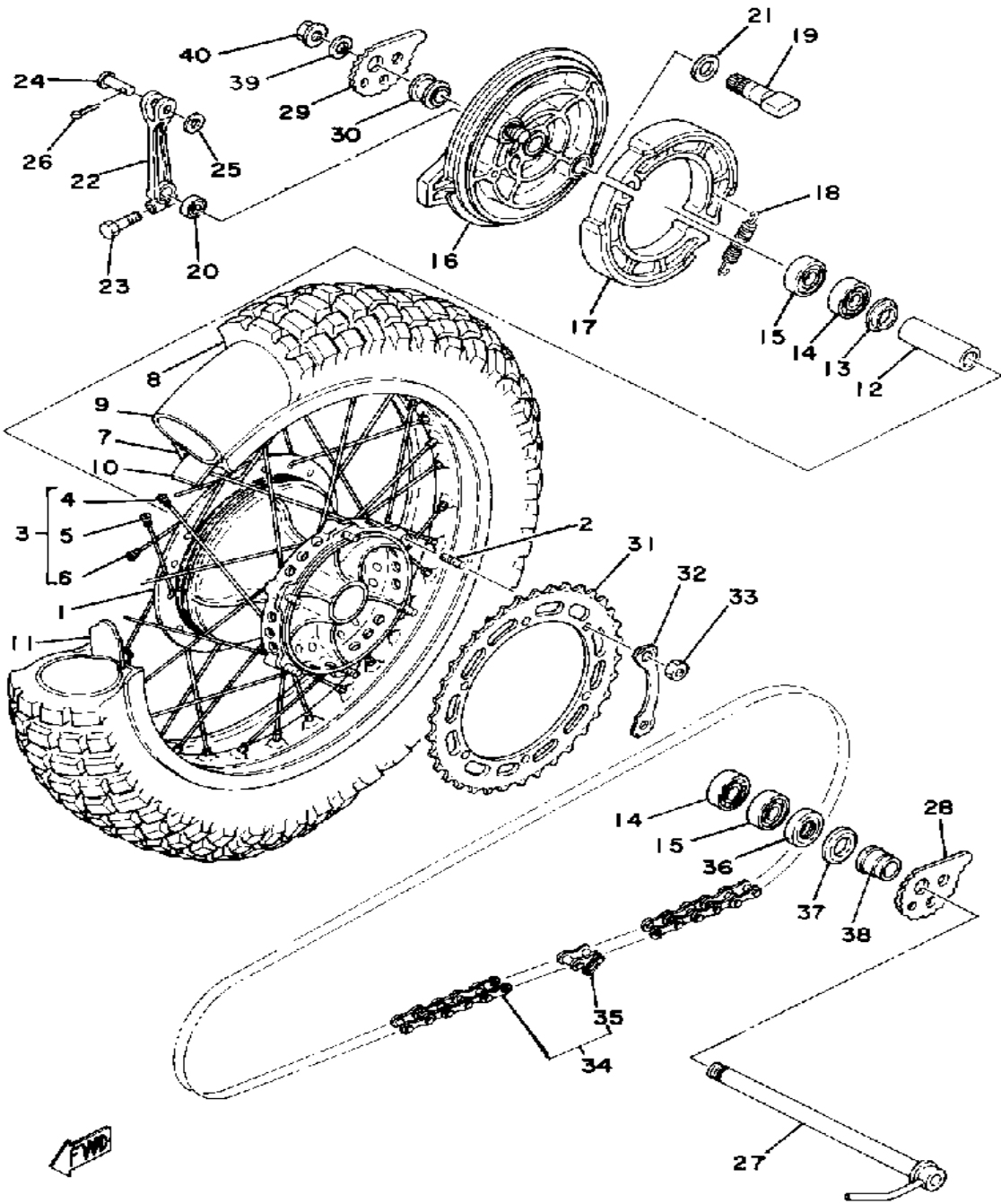

Ref. No.	Part Number	Description	Qty	Remarks
1	(483-25311-13-98)	HUB, REAR	1	LOW GLOSS BLK
2	90116-08218-00	BOLT, STUD	6	
3	431-25304-01-00	SPOKE SET, REAR (431-25304-00)	1	
4	(431-25396-90-00)	SPOKE SET, INNER 2	1	
5	(431-25391-90-00)	SPOKE SET, INNER 1	1	
6	(431-25392-90-00)	SPOKE SET, OUTER 1	1	
7	94421-18238-00	RIM 2.15X18 (94421-18151) (2.15-18)	1	
8	94114-186G1-00	140/90-18 M2A (TT)	1	
9	94245-18125-00	TUBE (4.50-18)	1	
10	94345-18081-00	BAND, RIM (4.50-18)	1	
11	1T1-25394-01-00	SPACER, BEAD	2	
12	483-25317-01-00	SPACER, BEARING	1	
13	483-25315-00-00	FLANGE, SPACER	1	
14	93306-20310-00	BEARING	2	
15	93306-20310-00	BEARING	2	
16	(1W6-25321-00-98)	PLATE, BRAKE SHOE	1	LOW GLOSS BLK
17	2X4-W2536-00-00	BRAKESHOE SET-2PCS	2	
18	90507-20002-00	SPRING, TENSION	2	
19	1E6-25151-00-00	CAMSHAFT	1	
20	148-25359-00-00	SEAL, CAMSHAFT	1	
21	148-25353-00-00	SHIM, CAMSHAFT	1	
22	4V5-25355-00-00	LEVER, CAMSHAFT (168-25355-00)	1	
23	90101-06291-00	BOLT	1	
24	1W2-27237-00-00	PIN, CLEVIS	1	
25	90201-12631-00	WASHER, PLATE	1	
26	91401-25030-00	PIN, COTTER	1	
27	1W6-25381-00-00	AXLE, WHEEL	1	

CONTINUED ON NEXT FRAME ►

REAR WHEEL

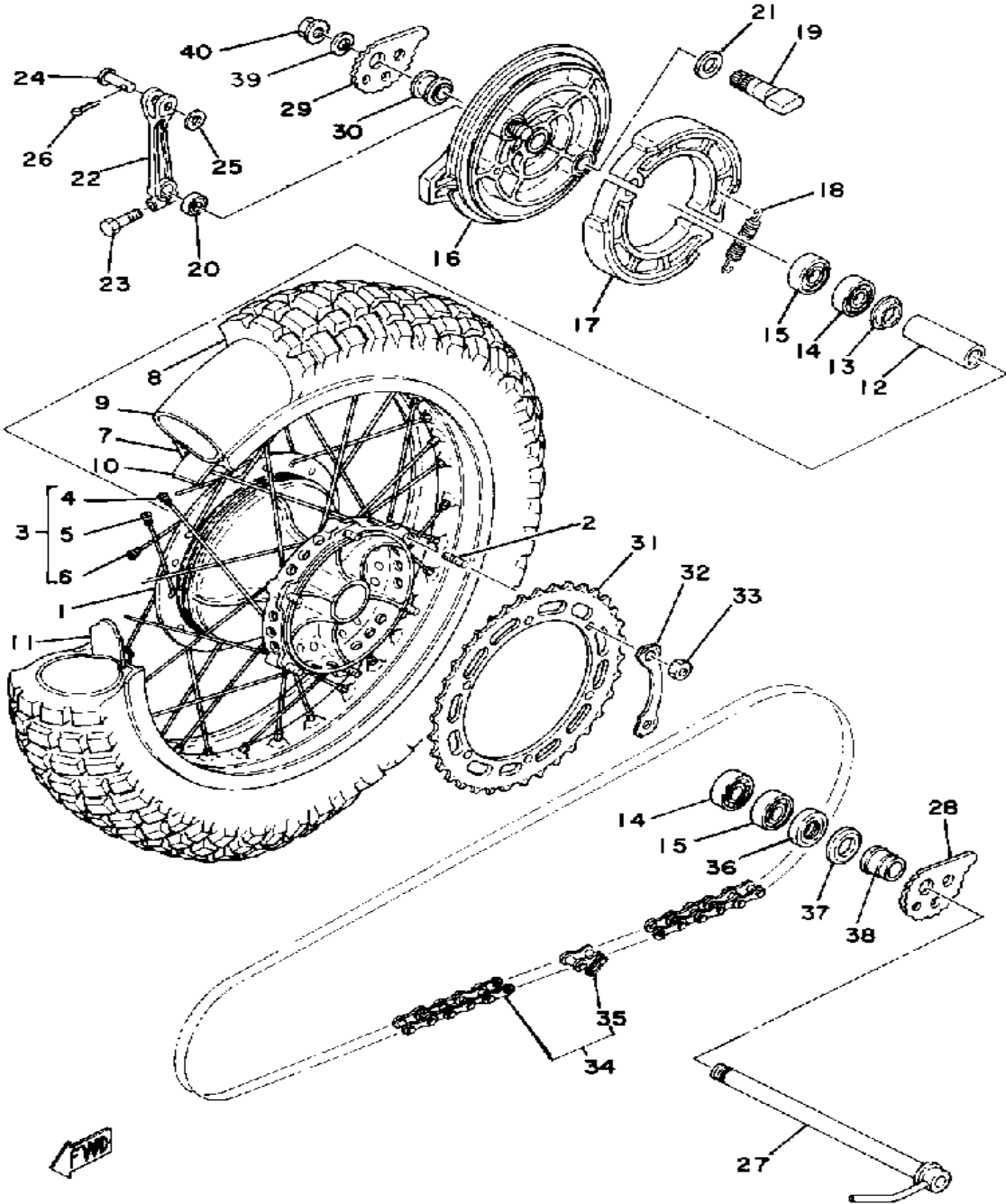

Ref. No.	Part Number	Description	Qty	Remarks
28	1M1-25388-01-00	PULLER, CHAIN 1	1	
29	1M1-25389-01-00	PULLER, CHAIN 2	1	
30	(90387-17618-00)	COLLAR	1	
31	(431-25448-04-XX)	SPROCKET, DRIVN 48T	1	
	(431-25452-04-XX)	SPROCKET, DRIVN 52T	1	
	38W-25444-20-00	SPROCKET, DRIVN 44T	1	
	431-25450-04-XX	SPROCKET, DRIVN 50T	1	
	431-25454-04-XX	SPROCKET, DRIVN 54T	1	
	583-25446-10-00	SPROCKET, DRIVN 46T	1	STD
	583-25448-10-00	SPROCKET, DRIVN 48T (48T)	1	
32	583-25412-00-00	WASHER	3	
33	90170-08193-00	NUT, HEXAGON	6	
34	9Y585-20101-00	CHAIN 520DS-103L (DID520DS-102L)	1	
35	94685-20001-00	. JOINT CHAIN	1	
36	93102-25061-00	OIL SEAL, SD-TYPE	1	
37	431-25367-00-00	COVER, HUB DUST	1	
38	90387-17555-00	COLLAR	1	
39	92901-16100-00	WASHER, SPRING	1	
40	90179-16007-00	NUT, SPEC'L SHAPE	1	

HEAD LAMP

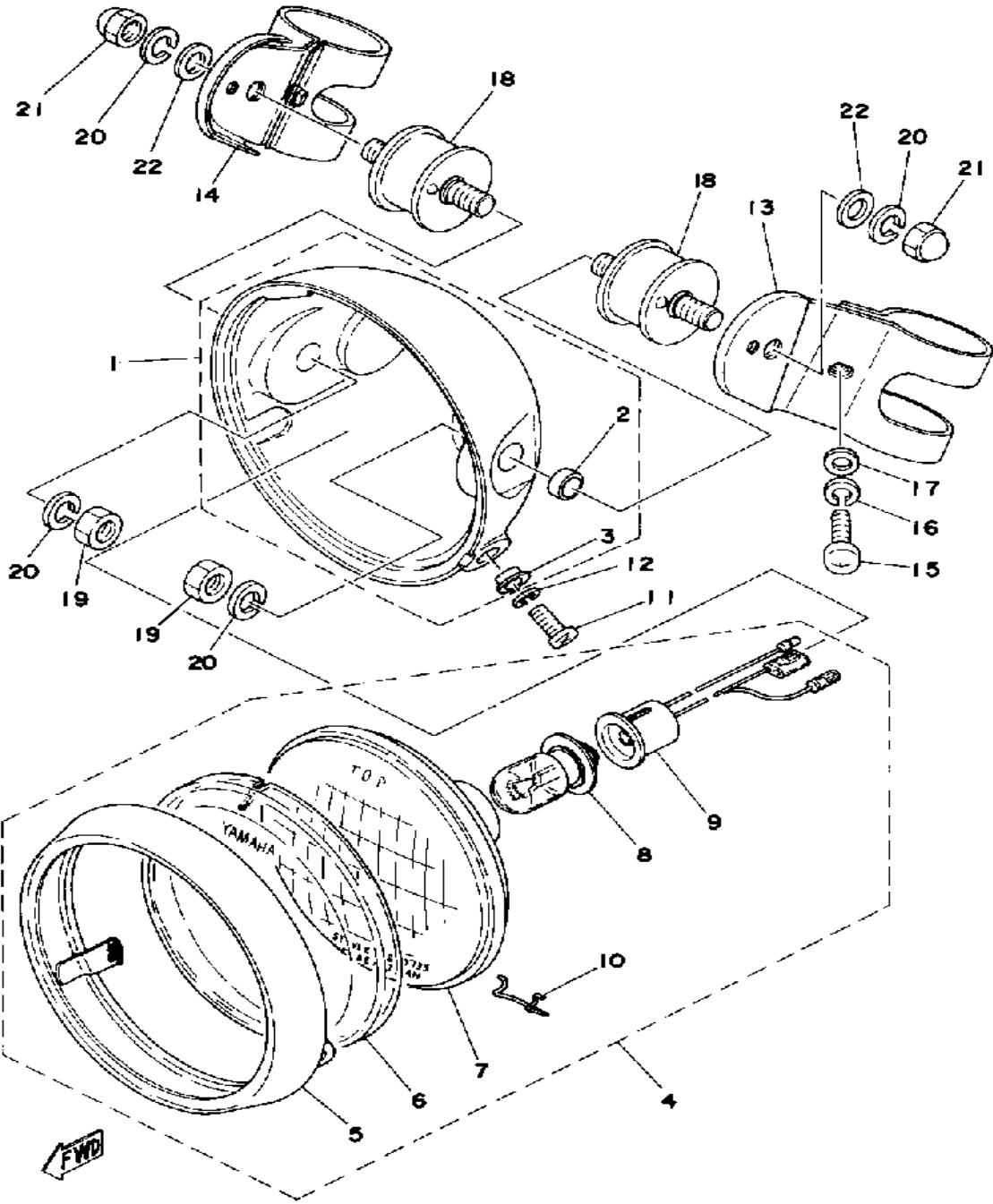

Ref. No.	Part Number	Description	Qty	Remarks
1	1W2-84130-60-00	BODY ASSEMBLY, HEADLIGHT	1	YAMAHA BLACK
2	(1W2-84145-60-00)	COLLAR, BODY FTNG	2	
3	1L9-84338-60-00	. COLLAR, BODY FTNG	1	
4	(1W2-84110-60-00)	UNAVAILABLE IN PRICE BOOK	1	N/A
5	(1W2-84115-60-00)	RIM, HEADLIGHT	1	
6	1W2-84144-60-00	. COVER, HEADLIGHT	1	
7	3R8-84120-60-00	. LENS ASSEMBLY	1	
8	527-84114-09-XX	. BULB, HL 6V25/25W	1	
9	1W2-84112-60-00	. SOCKET	1	
10	1W2-84324-60-00	. SPRING, REFLECTOR	4	
11	98580-05016-00	SCREW, PAN HEAD	1	
12	92990-05100-00	WASHER, SPRING	1	
13	(1W2-84118-00-33)	STAY, HEADLIGHT 1	1	YAMAHA BLACK
14	(1W2-84119-00-33)	STAY, HEADLIGHT 2	1	YAMAHA BLACK
15	98580-06020-00	SCREW	2	
16	92995-06100-00	WASHER, SPRING	2	
17	92901-06600-00	WASHER	2	
18	1W2-84143-00-00	DAMPER, HDLT STAY	2	
19	95333-08600-00	NUT	2	
20	92990-08100-00	WASHER	4	
21	95303-08800-00	NUT (CROWN) (95301-08800)	2	
22	92901-08600-00	WASHER	2	

SPEEDOMETER

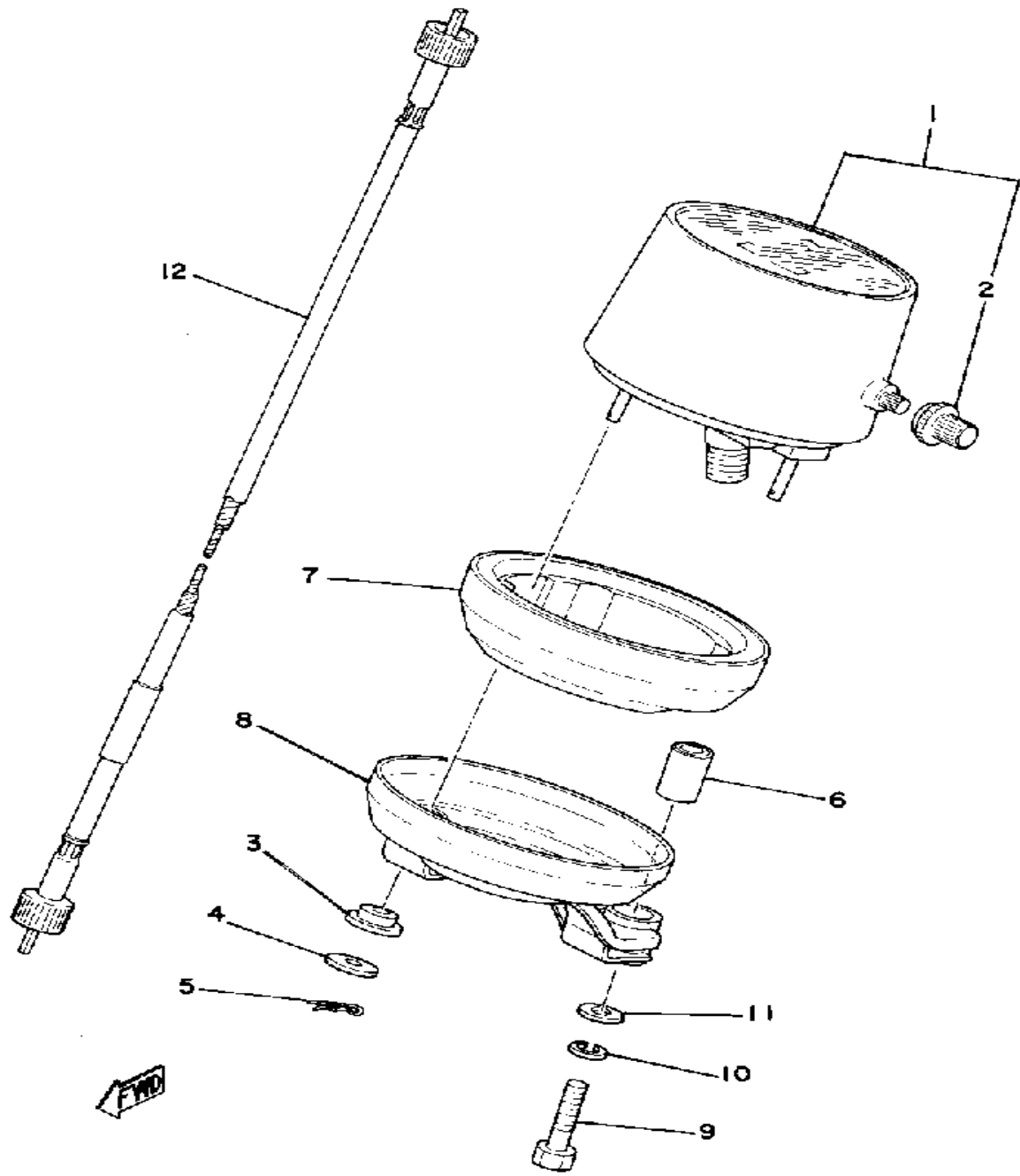

Ref. No.	Part Number	Description	Qty	Remarks
1	(2X7-83570-F0-00)	SPEEDOMETER ASSEMBLY ..	1	N/A
	2N4-83570-A0-00	SPEEDOMETER ASSEMBLY ..	1	MILE/H
2	1E6-83578-60-00	. KNOB, TRIP METER	1	
3	1M1-83526-00-00	DAMPER 2	2	
4	90201-052E2-00	WASHER, PLATE	2	
5	90468-10050-00	CLIP	2	
6	90385-06001-00	BUSH, SPEC'L RUBBER (214-83528-00)	2	
7	1W2-83513-00-00	DAMPER	1	
8	(1W2-83519-00-00)	BRACKET, METER	1	
9	97021-06030-00	BOLT	2	
10	92995-06100-00	WASHER, SPRING	2	
11	92901-06600-00	WASHER	2	
12	3R8-83550-00-00	SPEEDOMETER CABLE	1	

Headlight / Taillight / Signal Rating	6V25-25W / 6V5.3W / ϕ
---------------------------------------	----------------------------

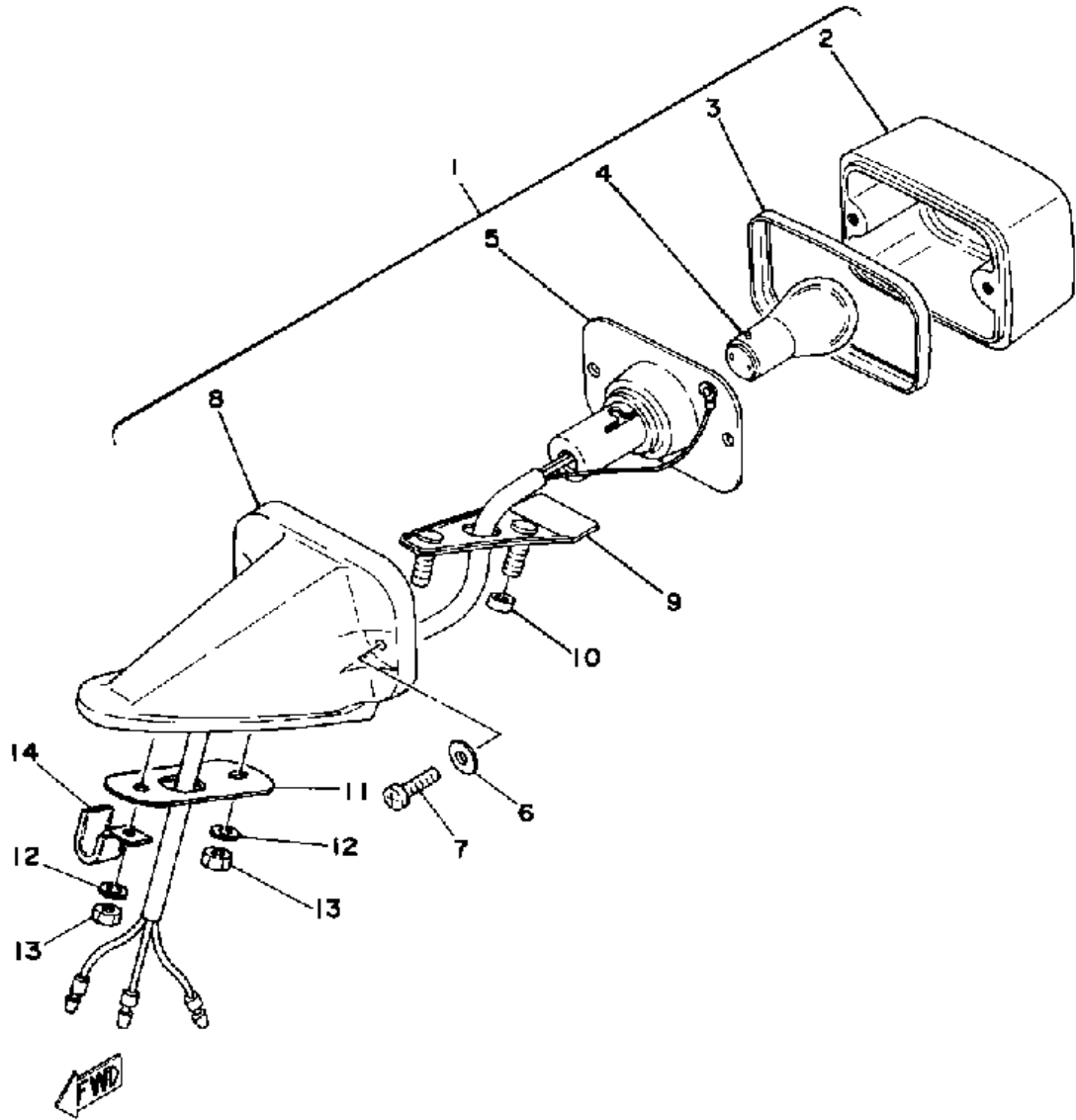

TAIL LAMP

Ref. No.	Part Number	Description	Qty	Remarks
1	434-84500-64-00	TAILLIGHT ASSEMBLY	1	
2	434-84521-69-00	. LENS, TAILLIGHT	1	
3	434-84515-61-00	. RIM, TAILLIGHT	1	
4	122-84514-30-00	. BULB	1	
5	434-84517-61-00	. CORD, TAILLIGHT	1	
6	434-84522-62-00	. WASHER	2	
7	434-84524-61-00	. SCREW, LENS FITTING	2	
8	434-84519-64-00	. BRACKET, TAILLIGHT	1	
9	434-84500-64-00	. TAILLIGHT ASSEMBLY	1	
10	(434-84557-60-00)	COLLAR	2	
11	1W2-84525-00-00	WASHER, SPECIAL	1	
12	92990-05100-00	WASHER, SPRING	2	
13	95380-05600-00	NUT	2	
14	90462-05005-00	CLAMP	1	

Ignition Timing 3.1mm BTDC

SPECIAL SERVICE TOOLS
 TLU-11080-32-00 TIMING LIGHT

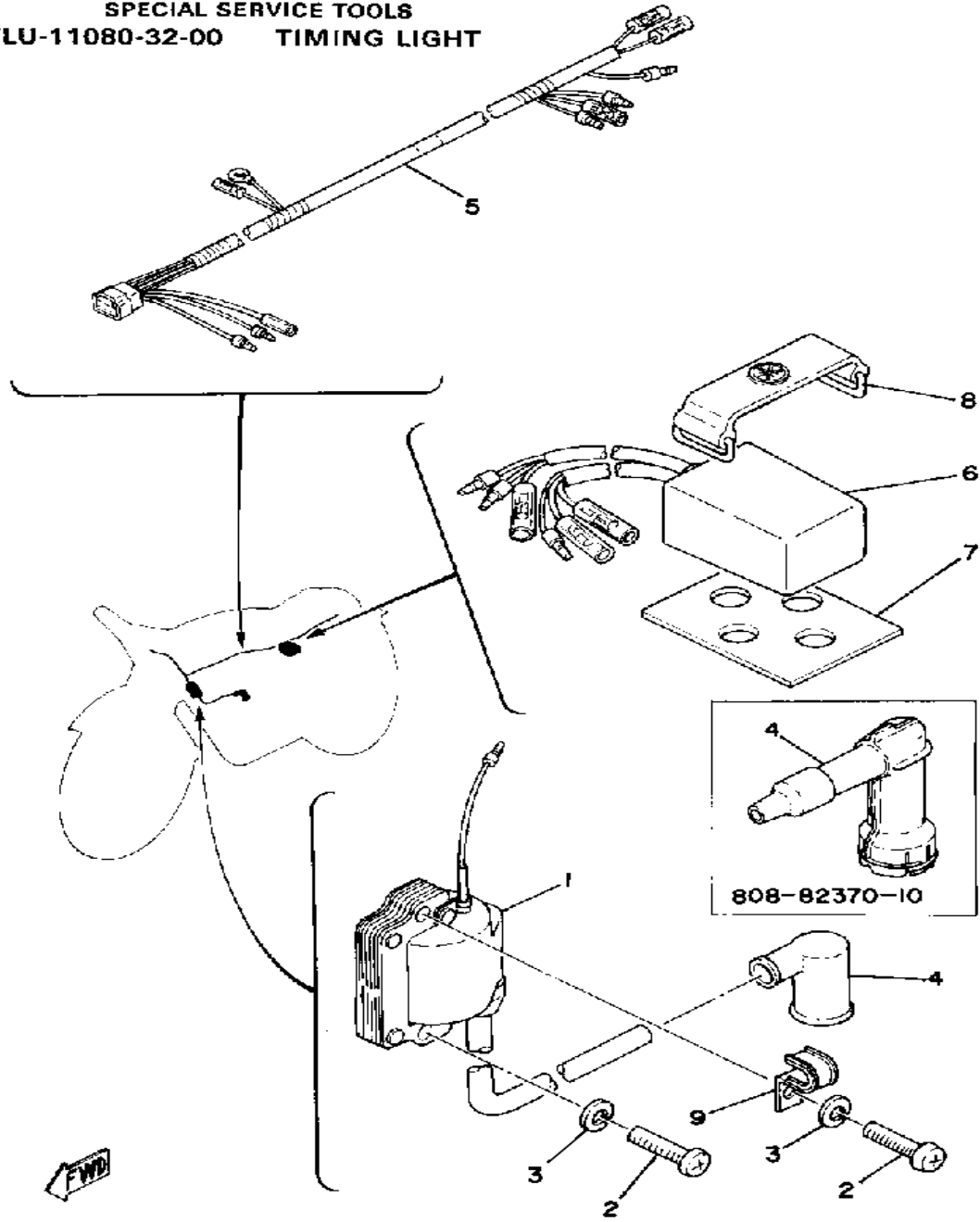

ELECTRICAL

Ref. No.	Part Number	Description	Qty	Remarks
1	5G4-82310-40-00	IGNITION COIL ASSEMBLY (J17-82310-21)	1	
2	98511-06025-00	SCREW PAN HEAD (92501-06025)	2	
3	92995-06100-00	WASHER, SPRING	2	
4	294-82370-00-00	PLUG CAP ASSEMBLY	1	
	808-82370-10-00	PLUG CAP ASSEMBLY	1	
5	(1W6-82590-00-00)	WIRE HARNESS ASSEMBLY	1	
6	2X7-85540-20-00	CDI UNIT ASSEMBLY	1	
7	2K7-85547-00-00	DAMPER	1	
8	21V-21376-00-00	BAND, TOOL	1	
9	90462-05005-00	CLAMP	1	

A-13
IT400F
1979 SERVICE DATA

MOTORCYCLE
M79-003

MODEL — IBM I.D. NUMBER	IT400F	2X8
Initial Engine Number/Frame Number	2X8-100101 / 2X8-100101	
Basic Color(s)	Sky Blue	
Fuel Type/Fuel Tank Capacity/Reserve Capacity	Premium / 12 Lit. (3.2 Gal.) / ϕ	
Dry Vehicle Weight	113 kg (249 lbs.)	
ENGINE TYPE	2-Stroke, Air-Cooled, Reed Valve	
Bore/Stroke/Number Cylinders/Displacement (cc)	82mm / 75mm / 1 / 396cc	
Compression Ratio/Compression Pressure min~max	7.4:1 / N/A	
Piston Skirt Clearance new/max.	0.050 ~ 0.055mm / 0.1mm	
Ring End Gap Top/2nd/3rd	0.40 ~ 0.55mm / 0.40 ~ 0.55mm / ϕ	
Valve Clearance (cold) Intake/Exhaust	ϕ	
Oil Pressure Hot/rpm	ϕ	
Oiling System	Premix (20:1)	
Capacity: Dry	ϕ	
Oil and Filter Change	ϕ	
Oil Change	ϕ	
Lubricant: Temp above 5°C (40°F)	Yamalube R*	
Below 15°C (60°F)	Yamalube R*	
AUTOLUBE — Min. Stroke/Color Code	ϕ	
Minimum Output @ 200 cycles	ϕ	
Maximum Output @ 200 cycles	ϕ	
CARBURETOR — Mfr./Type/I.D. Number	Mikuni / VM38SS / 2X800	
Main Jet/Pilot Jet	370 / 60	
Needle Jet/Jet Needle-Clip Position	Q-0 / 6F16-2	
Slide Cutaway or Throttle Valve	3.0	
Float Level	18.1 ± 1mm	
Idle rpm	ϕ	
CO % @ Idle (Diagnostic Use Only)	ϕ	
SUSPENSION		
Front Forks: Oil Type/Level/Qty.	20 wt. Fork Oil* / ϕ / 296cc	
Gas Pressure	ϕ	
Spring Length Std.	533.5mm	
Monoshock: Oil Type/Qty.	Not Rebuildable	
Gas Pressure	16 kg/cm ² (228 psi)	
Minimum Brake Lining Thickness	Front: 2mm Rear: 2mm	
Tire Size (Nominal Pressure)	F:3.00-21(0.9kg/cm ² /13 psi) R:4.50-18(1.0kg/cm ² /14 psi)	
TRANSMISSION — Oil Type/Qty Chg/Qty Reassemble	SAE 10W30 SE / 800cc / 850cc	
Primary Drive Type/Teeth/Ratio	Helical Gear / 60-23 / 2.608	
Secondary Drive Type/Teeth/Chain	Chain / 46-14 / DID520TR-102L	
Clutch Friction Plate Thickness Std ~ Min.	3.0 ~ 2.7mm	
Clutch Spring Length Std ~ Min.	36.0 ~ 35.0mm	
Middle Gear Case Capacity	ϕ	
Final Gear Case Capacity	ϕ	
Gear Case Lubricant: Temp above 5°C (40°F)	ϕ	
Temp below 15°C (60°F)	ϕ	
All Weather Conditions	ϕ	

Service Copy: _____ Service Mgr. _____ Mechanic _____ Mechanic _____ Mechanic _____ Binder

Office Copy: _____ General Mgr. _____ Sales _____ Parts _____ Binder

©YAMAHA MOTOR CORPORATION, U. S. A., BUENA PARK, CALIFORNIA January 24, 1979 PAGE 1 OF 2

CHARGING SYSTEM	Flywheel Magneto
Battery: Model / Spec. Grav. / Chg. Rate	ϕ
Maximum Output	ϕ
TROUBLESHOOTING	
Field Coil Color Code / Ω	ϕ
Charge Coil Color Code / Ω	ϕ
IGNITION SYSTEM	Capacitor Discharge Ignition
Ignition Timing	3.1mm BTDC
Spark Plug Type	Champion N-3G
Spark Plug Gap / Torque / Cap Ω	0.6 ~ 0.7mm / 2.3 m·kg / ϕ
Point Gap / Condenser Capacitance	ϕ / ϕ
TROUBLESHOOTING	
Ignition Coil Test Gap / Primary Ω / Secondary Ω	6mm / 1.0 Ω ± 10% / 5.9K Ω ± 20%
Pulse Coil or Pick-up Coil Color Code / Ω	Wht-Red ~ Blk / 4.0 Ω ± 10%
Source Coil Color Code / Ω	Brn ~ Blk / 240 Ω ± 10%
LIGHTING SYSTEM	
Headlight / Taillight / Signal Rating	6V25-25W / 6V5.3W / ϕ
TROUBLESHOOTING	
Lighting Coil Color Code / Ω	Yel-Red ~ Blk / 0.49 Ω ± 10%
TORQUE VALUES	
Front Axle Nut	15 x 1.5: 5.8 m·kg
Front Axle Holder Nut	ϕ
Rear Axle Nut	16 x 1.5: 7.76 m·kg
Rear Axle Pinch Bolt	ϕ
Clutch Nut	20 x 1.0: 7.5 m·kg (Use Lock Washer)
Drain Plug	14 x 1.25: 2.0 m·kg
Cylinder Head Cover	ϕ
Cylinder Head:	8 x 1.25: 2.5 m·kg
Engine Mounting Bolts: Front, Upper	8 x 1.25: 2.4 m·kg
Front, Lower	8 x 1.25: 2.4 m·kg
Rear, Upper	8 x 1.25: 2.4 m·kg
Rear, Lower	8 x 1.25: 2.4 m·kg

ϕ Does Not Apply to This Model

* Available From Yamaha Parts Distributors, Inc.

PAGE 2 OF 2

CHARGING SYSTEM	Flywheel Magneto
Battery: Model / Spec. Grav. / Chg. Rate	φ
Maximum Output	φ
TROUBLESHOOTING	
Field Coil Color Code / Ω	φ
Charge Coil Color Code / Ω	φ
IGNITION SYSTEM	Capacitor Discharge Ignition
Ignition Timing	3.1mm BTDC
Spark Plug Type	Champion N-3G
Spark Plug Gap / Torque / Cap Ω	0.6 ~ 0.7mm / 2.3 m·kg / φ
Point Gap / Condenser Capacitance	φ / φ
TROUBLESHOOTING	
Ignition Coil Test Gap / Primary Ω / Secondary Ω	6mm / 1.0 Ω ± 10% / 5.9K Ω ± 20%
Pulse Coil or Pick-up Coil Color Code / Ω	Wht-Red ~ Blk / 4.0 Ω ± 10%
Source Coil Color Code / Ω	Brn ~ Blk / 240 Ω ± 10%
LIGHTING SYSTEM	
Headlight / Taillight / Signal Rating	6V25-25W / 6V5.3W / φ
TROUBLESHOOTING	
Lighting Coil Color Code / Ω	Yel-Red ~ Blk / 0.49 Ω ± 10%
TORQUE VALUES	
Front Axle Nut	15 x 1.5: 5.8 m·kg
Front Axle Holder Nut	φ
Rear Axle Nut	16 x 1.5: 7.76 m·kg
Rear Axle Pinch Bolt	φ
Clutch Nut	20 x 1.0: 7.5 m·kg (Use Lock Washer)
Drain Plug	14 x 1.25: 2.0 m·kg
Cylinder Head Cover	φ
Cylinder Head:	8 x 1.25: 2.5 m·kg
Engine Mounting Bolts: Front, Upper	8 x 1.25: 2.4 m·kg
Front, Lower	8 x 1.25: 2.4 m·kg
Rear, Upper	8 x 1.25: 2.4 m·kg
Rear, Lower	8 x 1.25: 2.4 m·kg

φ Does Not Apply to This Model

* Available From Yamaha Parts Distributors, Inc.